

Hands-on Electronics



Build The . . . Mini-Marque

An LED light-chaser that dresses up your favorite photographs!

Portable Electronics Workbench

Sets up in a snap—and cleans up just as fast!

Rapid Fire

Add our autofire accessory to your joystick and zap those aliens before they zap you!

Plus—

- Power supplies for hobbyists!
- Reducing computer redundancy!
- Restoring a shutter-dial radio!
- An SW broadcaster who's really number one!

SQUIRT GUNS THAT SCORE

Outdoor fun for kids of all ages!

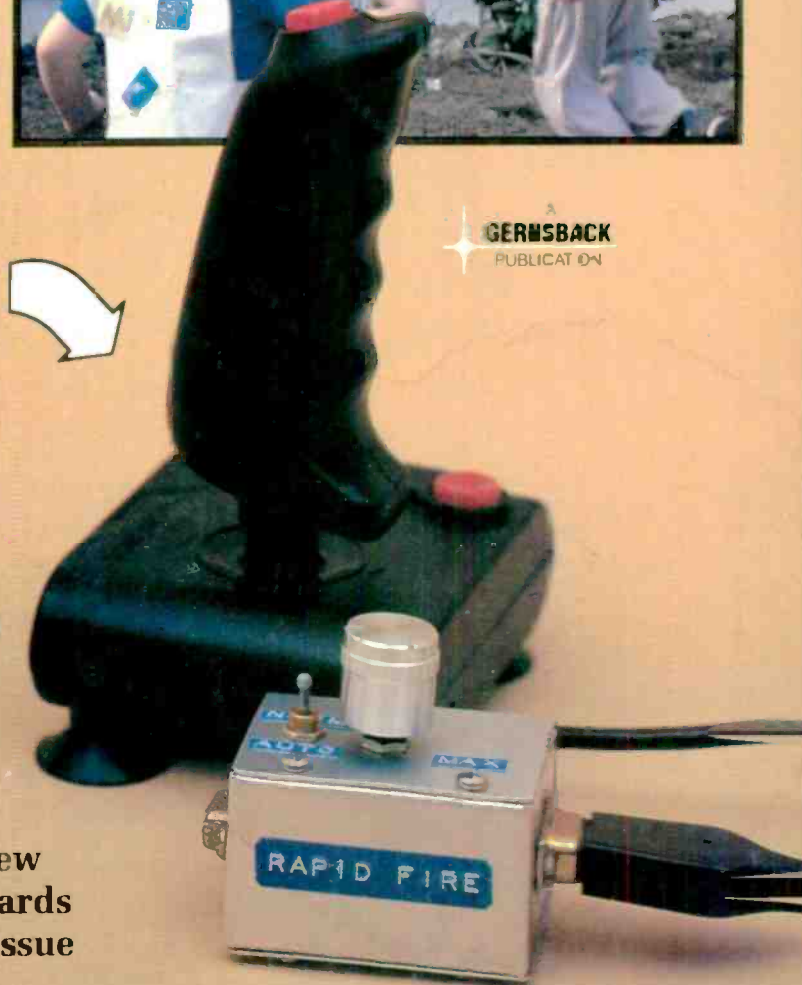

GERNSBACK
PUBLICATION

48784



\$2.50 U.S.
\$2.95 CANADA

3 New
FactCards
This Issue

CONSTRUCTION

- 29 **Squirt Guns That Score**—summer fun enters the electronics age
- 35 **Rapid Fire**—give your joystick the firepower needed to blow the invading alien armada into another galaxy
- 39 **Electronic Cricket**—it may not be a locust, but it's sure to plague those who hear its intermittent chirp
- 68 **Mini-Marque**—display your favorite photos in a flickering frame

FEATURES

- 8 **Inside the Computer Class**—a look at the lighter side of computing
- 41 **5 Classic Antennas**—perhaps one or more of these RF collectors could improve your hobby-communications setup
- 45 **Keep That Auto Cassette Deck in Tip-Top Shape**—repair the most-common auto cassette-deck ailments
- 50 **Old Dog-New Tricks**—it's never too late to join the computer age
- 64 **Kites an Antenna Supports**—hams and shortwave listeners can benefit from these high-flying toys

ELECTRONIC THEORY

- 32 **Crystal Audio Filter**—eliminate the fuzz that can obscure communications without spending a bundle
- 33 **Portable Electronics Workbench**—hideaway workstation for the space-conscious electronics hobbyist
- 44 **Rubber Crystal Oscillator**—a stable oscillator with a tunable difference
- 73 **E-Z Math**—using pulse and digital signals and circuits

HANDS-ON REPORTS

- 52 **Zebra Systems Car Sign Designer Kit**—create custom signs for your car's rear window.

SPECIAL COLUMNS

- 82 **Ellis on Antique Radio**—the Zenith restoration continues
- 84 **Circuit Circus**—designing your own power supply
- 86 **Jensen on DXing**—West African broadcaster lives up to its name
- 88 **Saxon on Scanners**—a base station with all sorts of goodies
- 91 **Friedman on Computers**—polling devices reduce computer redundancy
- 92 **Carr on Ham Radio**—multi-band wire antennas

DEPARTMENTS

- 2 **Editorial**—we mourn the dimming of an electronics superstar
- 4 **Letter Box**—here's what your fellow readers have to say
- 14 **New Products Showcase**—where the electronics manufacturers vie for your attention
- 24 **Bookshelf**—communications, audio/video, computing, and more
- 37 **FactCards**—all sorts of useful information for the do-it-yourselfer
- 53 **GIZMO Special Section**—what's new in electronic gadgetry
- 71 **Free Information Card**—cut through the information relay by going directly to the source



Squirt-Guns That Score—page 29



Portable Workbench—page 33



Rapid Fire—page 35

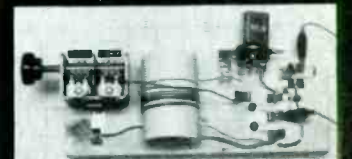

Rubber Crystal Oscillator—page 44



Car Sign Designer Kit—page 52



Friedman on Computers—page 91

Hands-on Electronics®

The Magazine for the Electronics Activist!

Mr. Metal Locator

Dr. Gerhard Fisher, a pioneer electronics experimenter died recently after a brief illness. He was 89. His name was unknown to me, yet when I read about his accomplishments, I realized that I knew him well.

As a young graduate of the University of Dresden, Dr. Fisher emigrated to the United States in 1923. He worked as a research scientist for several major U.S. corporations and the U.S. Navy, and associated with some of the great minds of the day including Lee deForest and Albert Einstein.

Dr. Fischer received several patents for his work on aircraft direction finders. Those who knew the old DC-3 remember that the aircraft had a loop on its forward belly—that loop was his doing. When using some of the earlier direction finders, however, pilots discovered errors in their bearings whenever they were over certain areas. Those areas eventually proved to be large metal roofs or highly conductive, mineralized soil. From that information, Dr. Fisher concluded that an instrument could be developed to detect the presence of metal or ore deposits.

Starting in his garage, he and four employees began producing the *Metallascope*—the first metal detector. In 1937, Dr. Fisher was granted the first metal-detector patent. The *Metallascope*, nicknamed the M-Scope, became an accepted standard for all types of electronic metal detection. It was because of his genius and tenacity that countless thousands enjoy the hobby of treasure hunting on weekends and vacations.

Dr. Fisher's company survives him. Known as the Fisher Research Laboratory, a subsidiary of COCU, Inc., it continues to design and manufacture underground detection instruments for industrial, government, law-enforcement, archaeological, and consumer use. I know that metal-detector users around the world join us in mourning the loss of this man who has given us such a beneficial and truly amazing device, and an exciting hobby.



Dr. Gerhard R. Fisher
1899-1988

Julian S. Martin, KA2GUN
Editor

STAFF

Volume 5, No. 9

September 1988

Larry Steckler, EHF, CET
Editor-In-Chief & Publisher

Art Kleiman, editorial director

Julian S. Martin, KA2GUN, editor

Carl Laron, WB2SLR, managing editor

Robert A. Young, associate editor

Herb Friedman, W2ZLF, associate editor

John J. Yacono, associate editor

Brian C. Fenton, associate editor

Byron G. Wels, K2AVB, associate editor

Teri Scaduto, assistant editor

Kathryn Campbell, editorial assistant

Ruby M. Yee, production director

Karen S. Tucker, production manager

Robert A. W. Lowndes, editorial
associate

Marcella Amoroso, production assistant

Andre Duzant, technical illustrator

Injae Lee, assistant illustrator

Jacqueline P. Cheeseboro, circulation director

Nancy Estrada, manager, HOE Bookstore

BUSINESS AND EDITORIAL OFFICES

Gernsback Publications, Inc.

500-B Bi-County Boulevard
Farmingdale, NY 11735.

516/293-3000

President: Larry Steckler

Vice-president: Cathy Steckler

Cover photography by
Herb Friedman
and
Thomas R. Fox

Composition by
Mates Graphics

Advertising Sales Offices listed on page 105.



Hands-on Electronics, (ISSN 0743-2968) Published monthly by Gernsback Publications, Inc., 500-B Bi-County Boulevard, Farmingdale, NY 11735. Second-Class postage paid at Farmingdale, NY and at additional mailing offices. Subscription orders payable in U.S. funds only. International Postal Money Order or check drawn on a U.S. bank. U.S. single copy price \$2.50. © 1988 by Gernsback Publications, Inc. All rights reserved. Trademark registered in U.S. and Canada. Printed in U.S.A.

Postmaster: Please send address changes to Hands-On Electronics, Subscription Dept., P.O. Box 338, Mount Morris, IL 61054-9932.

A stamped self-addressed envelope must accompany all submitted manuscripts and/or artwork or photographs if their return is desired should they be rejected. We disclaim any responsibility for the loss or damage of manuscripts and/or artwork or photographs while in our possession or otherwise.

As a service to readers, Hands-on Electronics publishes available plans or information relating to newsworthy products, techniques and scientific and technological developments. Because of possible variances in the quality and condition of materials and workmanship used by readers, Hands-on Electronics disclaims any responsibility for the safe and proper functioning of reader-built projects based upon or from plans or information published in this magazine.

SELECT 5 BOOKS for only \$3.95

(values to \$134.70)
and get a Free Gift!

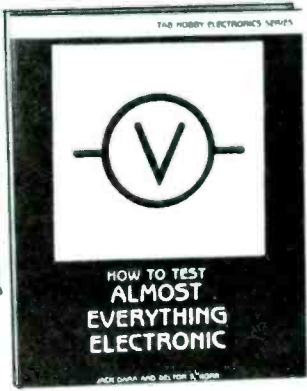
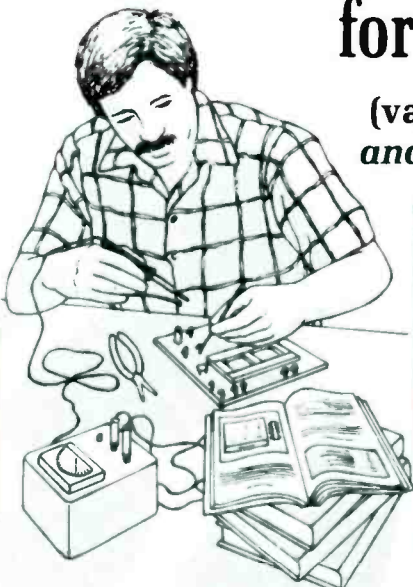

2925 \$15.95

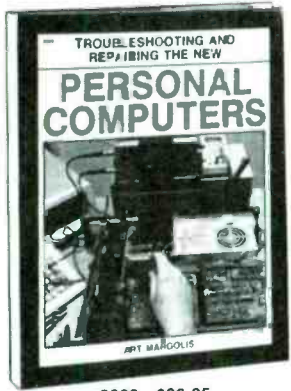

2809 \$26.95
Count as 2



1897P \$13.95



2617 \$17.95



1599P \$17.95



2905 \$19.95



2912 \$23.95



1493P \$14.95

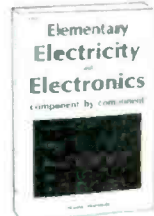

2753P \$16.95

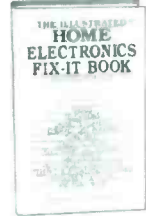

2883 \$25.95

Electronics projects . . . ideas . . . the latest technology
all at up to 50% off publishers' prices

Membership Benefits • Big Savings. In addition to this introductory offer, you keep saving substantially with members' prices of up to 50% off the publishers' prices. • **Bonus Books.** Starting immediately, you will be eligible for our Bonus Book Plan, with savings of up to 80% off publishers' prices. • **Club News Bulletins.** 14 times per year you will receive the Book Club News, describing all the current selections—mains, alternates, extras—plus bonus offers and special sales, with hundreds of titles to choose from. • **Automatic Order.** If you want the Main Selection, do nothing and it will be sent to you automatically. If you prefer another selection, or no book at all, simply indicate your choice on the reply form provided. As a member, you agree to purchase at least 3 books within the next 12 months and may resign at any time thereafter. • **Ironclad No-Risk Guarantee.** If not satisfied with your books, return them within 10 days without obligation! • **Exceptional Quality.** All books are quality publishers' editions especially selected by our Editorial Board.

All books are hardcover unless numbers are followed by a "P" for paperback. (Publishers' Prices Shown)
© 1988 ELECTRONICS BOOK CLUB®, Blue Ridge Summit, PA 17294-0810

FREE when you join!

Here's 15 Best Electronic Projects From Delton T. Horn Projects you can build—some unique, some old favorites—from the author's vast treasury of electronics know-how.

(a \$7.95 value!)

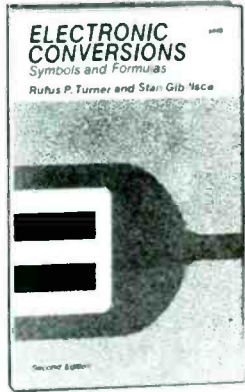
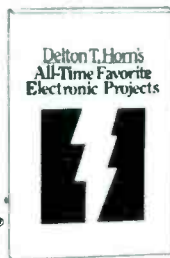

2865 \$21.95

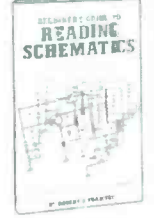

1536P \$8.45

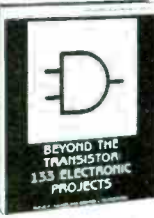

2887 \$16.95



2706 \$15.95



2613 \$23.95



2724 \$24.95



2707 \$26.95
Counts as 2



2750 \$25.95



2867 \$24.95



2705P \$14.95



2685 \$24.95

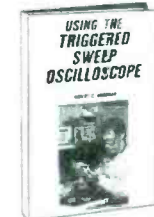

2853 \$23.95

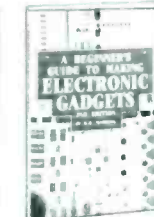

1793P \$9.95



2861 \$14.95



2731 \$21.95

ELECTRONICS BOOK CLUB®
Blue Ridge Summit, PA 17294-0810

Please accept my membership in the Electronics Book Club® and send the 5 volumes listed below, plus my FREE copy of Delton T. Horn's All-Time Favorite Electronic Projects (3105P), billing me \$3.95 plus shipping and handling charges. If not satisfied, I may return the books within ten days without obligation and have my membership canceled. I agree to purchase at least 3 books at regular Club prices (plus shipping and handling) during the next 12 months and may resign any time thereafter.

Name _____
Address _____
City _____
State/Zip _____ Phone _____
Signature _____

Valid for new members only. Foreign applicants will receive special ordering instructions. Canada must remit in U.S. currency. This order subject to acceptance by the Electronics Book Club®.
Signature of parent or guardian required for all new members under 18 years of age. RESP-988

LETTER BOX

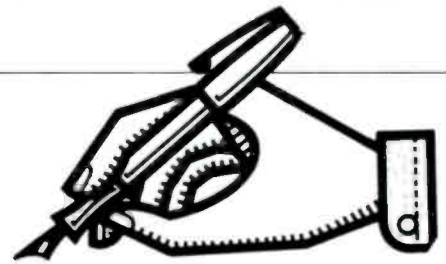

Hands-on Electronics, 500B Bi-County Boulevard, Farmingdale, New York 11735

Part Alert

In Listen in on the Tube in the January 1988 issue, U1 is specified as a TLC272, Radio Shack part number 276-1749. Radio Shack tells me that that is a discontinued part. Do you know where else I can get one, or could you suggest a suitable alternative?

I also would like to pass along the following corrections to the article: On the parts-placement diagram, capacitor C6 is shown twice; the non-electrolytic one is really C8. Also, the positions of R8 and C9 are reversed. Incidentally, C8 and C9 do not need to be electrolytics; they are specified as such in the Parts List.

—D.A., Sequim, WA

We don't have an alternate source for the TLC272, however that part is not especially critical. Any low-noise, high-impedance op-amp with JFET inputs can be used. In particular, the MC34002P, the TL072CP, and the TLO82CP are suitable pin-for-pin replacements and any of those can be used in the project without modifying the circuit. The TLO82 is currently available from Radio Shack (part number 276-1715).

Checking Out Static

In the May 1988 issue of **Hands-on Electronics**, in our article on static electricity, the author referred to "styrofoam cups" and "styrofoam packing material." Actually, according to the people of The Dow Chemical Corporation, the correct terms to use are "polystyrene cups" and "polystyrene packing material." Most molded polystyrene products are made from expandable polystyrene beads. Each bead is about the size of the ball in a ball-point pen. Each holds a bit of entrapped gas—a blowing agent. Those beads are poured into a mold. Heat is applied, the gas expands, and the beads swell to fill the mold.

Styrofoam-brand products are not molded products. Now, here is the difference! In an extruding device, a solidifying mass of polystyrene foam is pushed through a die, creating a board of Styrofoam-brand plastic foam. Styrofoam is a brand name of The Dow Chemical Corporation and it should only be used when referring to the extruded-polystyrene products of that company. So, if it isn't made by Dow, it's not Styrofoam!

Are the Dow people getting a bit sticky over this? Not really. They provided us with the information because they want us to use their brand name correctly. If they do not insist on its proper use, they may lose the right to use the name Styrofoam exclusively. That has happened to other companies in the past. A classic example is cellophane. Cellophane was once a brand name. Now, because the company that originated it did not protect its use, it is a generic term that anyone can use. So please substitute the word polystyrene for Styrofoam in the static electricity article.

—Editor

Building a Workbench

I've been reading your magazine for just a few months now, and I think it's great! I especially like the Circuit Circus column; many of the circuits there have been useful additions to my workbench, without being serious subtractions from my wallet!

Now, I am looking for a simple IC tester that can be built on a modest hobbyist's budget. Any plans for an article?

—R.S., Chatham, NY

Check out the Digi-lyzer IC Tester in the August, 1987 issue. It uses easily found, inexpensive components to separate good integrated circuits from bad. If you don't have that issue in your collection, it can be ordered through our Reprint Bookstore.

A New Hobbyist

I am a disabled veteran (W.W II) and housebound. As a result, I fill much of my time reading anything I can get a hold of. Since I am just getting interested in electronics, when someone showed me a copy of your magazine it was like a dream come true.

Well, almost!

Unfortunately, I am a true beginner in the hobby, and even some of the basic stuff on your pages, let alone the more advanced projects, goes way over my head. What I need is a couple of books on basic electronics. You know, things like how a relay or capacitor works, etc., with some quick and easy projects. Any recommendations?

I also would love to see a couple of pages dedicated to the beginning hobbyist in each issue.

Thanks for listening, and what I do understand in your magazine is swell!

—B.E., Delray Beach, FL

Readers, let's help B.E. out. Write in and let us know which beginning electronics book, etc., helped you over the hump when you were just starting out, and we'll pass the information along.

Who Needs Change?

Your editorial in the May, 1988 issue is entitled "Times are Changing!"

I say, "So what!"

I am a TV-studio maintenance crew chief, and I don't feel that computers should enter every facet of my life. Does a computer in a car make that car more reliable or easier to maintain? Or does it just make it tougher to find someone who's capable of maintaining the car?

My point is that I wish you'd leave the computer projects to the "hacker" magazines. Anything more than two pages of computer-related stories per issue is more than I can stand.

Do not end up like other magazines who sold out to computers, only to be left with no audience at all. Give the

readers what they want: basic circuits and fun, easy-to-build projects.

And don't just SAY that your are going to "quell my fears"—Do it!
—A.R., Hackensack, NJ

Readers, Do you agree or disagree with A.R.? Let's hear your opinions on this, too!

Aircraft Codes

I am an avid reader of "Saxon on Scanners." Like many of that column's readers, I use a scanner to monitor civil-aircraft frequencies as a hobby. Here's some information that I thought other scanner hobbyists might appreciate.

In aircraft communications, a variety of codes are used to indicate emergency or unusual conditions. For instance, a pilot transmitting a code 7600 is letting controllers know that two-way communications have been lost. A code 7700 is used for any other emergency. Those codes are automatically recognized by the ground radar's computer, which draws a distinctive symbol on the controller's visual display and sounds an alarm. Code 1200 is used by aircraft flying under visual-flight rules. Other transponder codes that are assigned to aircraft by controllers are displayed next to the aircraft's blip on the radar screen so that each is positively identified. In addition, many aircraft have an altitude encoder connected to the transponder that causes the aircraft's altitude to be displayed along with the transponder code to reduce the controller's communications workload.

By the way, I think you have a great magazine. Very few of the electronics magazines that remain feature construction articles, and none have as many as yours. And your mix of computer/microprocessor stories versus those dealing with other areas of electronics is just about right.

To be sure, a microprocessor is a versatile component that can be used to simplify electronics designs. For example, imagine the component count and printed-circuit-board real estate it would take to implement the "Compu-Throttle" model-railroad controller (March, 1988) without microprocessors.

On the other hand, those who have abandoned other areas of electronics in favor of coverage of computer-related electronics have done their readers a dis-service—and some have paid a heavy penalty for their actions. Please

CABLE-TV

**WE'LL MATCH OR BEAT ANYONE'S
ADVERTISED RETAIL OR WHOLESALE PRICES!**

BONANZA!

ITEM	1 UNIT	10 OR MORE
RCA 36 CHANNEL CONVERTER (Ch. 3 output only)	29.00	18.00
PANASONIC WIRELESS CONVERTER (our best buy)	88.00	69.00
400 OR 450 CONVERTER (manual fine tune)	88.00	69.00
*JERROLD 400 COMBO	169.00	119.00
JERROLD 400 HAND REMOTE CONTROL	29.00	18.00
*JERROLD 450 COMBO	199.00	139.00
*JERROLD 450 HAND REMOTE CONTROL	29.00	18.00
JERROLD SB-ADD-ON	89.00	58.00
*JERROLD SB-ADD-ON WITH TRIMODE	99.00	70.00
*M-35 B COMBO UNIT (Ch. 3 output only)	99.00	70.00
*M-35 B COMBO UNIT WITH VARISYNC	109.00	75.00
*MINICODE (N-12)	89.00	58.00
*MINICODE (N-12) WITH VARISYNC	99.00	62.00
*MINICODE VARISYNC WITH AUTO ON-OFF	145.00	105.00
ECONOCODE (minicode substitute)	69.00	42.00
ECONOCODE WITH VARISYNC	79.00	46.00
*MLD-1200-3 (Ch. 3 output)	99.00	58.00
*MLD-1200-2 (Ch. 2 output)	99.00	58.00
*ZENITH SSAVI CABLE READY	175.00	125.00
INTERFERENCE FILTERS (Ch. 3 only)	24.00	14.00
*EAGLE PD-3 DESCRAMBLER (Ch. 3 output only)	119.00	65.00
*SCIENTIFIC ATLANTA ADD-ON REPLACEMENT DESCRAMBLER	119.00	75.00

*CALL FOR AVAILABILITY

Quantity	Item	Output Channel	Price Each	TOTAL PRICE
California Penal Code #593-D forbids us from shipping any cable descrambling unit to anyone residing in the state of California.			SUBTOTAL	
Prices subject to change without notice.			Shipping Add \$3.00 per unit	
PLEASE PRINT			COD & Credit Cards — Add 5%	
Name _____			TOTAL	
Address _____ City _____				
State _____ Zip _____ Phone Number () _____				
<input type="checkbox"/> Cashier's Check <input type="checkbox"/> Money Order <input type="checkbox"/> COD <input type="checkbox"/> Visa <input type="checkbox"/> Mastercard				
Acct # _____ Exp. Date _____				
Signature _____				

FOR OUR RECORDS:

DECLARATION OF AUTHORIZED USE — I, the undersigned, do hereby declare under penalty of perjury that all products purchased, now and in the future, will only be used on cable TV systems with proper authorization from local officials or cable company officials in accordance with all applicable federal and state laws. **FEDERAL AND VARIOUS STATE LAWS PROVIDE FOR SUBSTANTIAL CRIMINAL AND CIVIL PENALTIES FOR UNAUTHORIZED USE.**

Dated: _____ Signed: _____

Pacific Cable Company, Inc.

7325½ RESEDA BLVD., DEPT. # H-9 • RESEDA, CA 91335
(818) 716-5914 • No Collect Calls • (818) 716-5140

IMPORTANT: WHEN CALLING FOR INFORMATION
Please have the make and model # of the equipment used in your area. Thank You

LETTERBOX

continue to publish a wide variety of articles on a wide variety of electronics topics.

—W.H., San Francisco, CA

Thanks for the scanner info, W.H. We're sure that other readers of "Saxon on Scanners" will find that information useful. (Scanner buffs should turn to page 88.)

On your other point, rest assured that we're dedicated to serving hobbyists in ALL areas of electronics. That's why we're always appealing to you, our readers, for story ideas and articles. That way, we can keep our finger on the pulse of what YOU want to see in these pages.

Marking Time

I just received my copy of the July 1988 issue of **Hands-on Electronics** and was most pleased with the way my article on the Perpetual Calendar was presented.

I do, however, have three minor corrections. In the schematic, Fig. 1, the 0.1-Hz and the .01-Hz reference on U3 have been reversed. The text is correct.

The other two corrections have to do with figure references: On page 29, directly under the headline Cosmo-Time, the reference made to Fig. 5 should be to Fig. 6.

Second, on the second-to-last line on page 29, the reference to Fig. 4 should be to Fig. 5.

All of those corrections should be obvious to the reader, and do not seriously affect building the project, but pointing them out will certainly do no harm.

—Paul W. Aman

Easy Listening

I would like to thank you for your recent assistance. We ran into a minor problem in building the Listening Tube described in the January 1988 issue. Your response to our letter cleared up our confusion and our project is now working perfectly.

My kids have had a lot of fun with the Listening Tube, and won Honorable Mention in the Science Fair with it.

—R.W.D., Tulsa, OK

Thanks for the kind words. We try to be as helpful as we can with reader questions, especially when they pertain

Inside the Computer Class

By Harry Nelson



"The trend is that more white-collar crime will be done by computer. I'm educating a bunch of criminals."



"Today, students, we will discuss stock market analysis software. I realize that for some of you, it's too late!"



"Until I find out otherwise, I'll assume that one of you has access to the florist's computer network!"



"It was after the stock-market crash, Dean Wells, that I got a very heavy enrollment of middle-age businessmen."



"I'm afraid I must insist, Ms. Estrada! The university's super computer is not to be used to evaluate your boyfriends."



"Good golly, Mrs. Strassman, I think it is very unfair to have our computer evaluate our classroom progress."

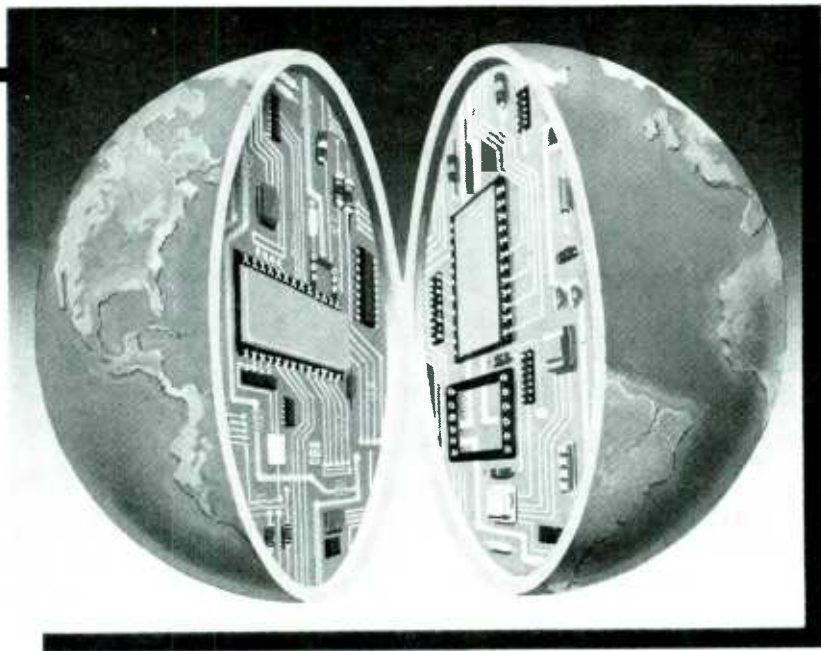

can even earn your Associate in Applied Science Degree in Electronics Engineering Technology. Of course, you set your own pace, and, if you ever have questions or problems, our instructors are only a toll-free phone call away.

The first step is yours.

To find out more, mail in the coupon below. Or, if you prefer, call toll-free 1-800-321-2155 (in Ohio, 1-800-523-9109). We'll send you a copy of CIE's school catalog and a complete package of enrollment information. For your convenience, we'll try to have a representative contact you to answer your questions.

CIE MAKES THE WORLD OF ELECTRONICS YOURS.

Today's world is the world of electronics. But to be a part of it, you need the right kind of training, the kind you get from CIE, the kind that can take you to a fast growing career in business, medicine, science, government, aerospace, communications, and more.

Specialized training.

You learn best from a specialist, and that's CIE. We're the leader in teaching electronics through independent study, we teach only electronics and we've been doing it for over 50 years. You can put that experience to work for you just like more than 25,000 CIE students are currently doing all around the world.

Practical training.

You learn best with practical training, so CIE's Auto-Programmed® lessons are designed to take you step-by-step, principle-by-principle. You also get valuable hands-on experience at every stage with sophisticated electronics tools CIE-designed for teaching. Our

4K RAM Microprocessor Training Laboratory, for example, trains you to work with a broad range of computers in a way that working with a single, stock computer simply can't.

Personalized training.

You learn best with flexible training, so we let you choose from a broad range of courses. You start with what you know, a little or a lot, and you go wherever you want, as far as you want. With CIE, you



AHO-92

CIE Cleveland Institute of Electronics

1776 East 17th St., Cleveland, Ohio 44114

YES! I want to get started. Send me my CIE school catalog including details about the Associate Degree Program. I am most interested in:

- computer repair
- television/high fidelity service
- telecommunications
- medical electronics
- robotics/automation
- broadcast engineering
- other _____

Print Name _____

Address _____ Apt. _____

City _____ State _____ Zip _____

Age _____ Area Code/Phone No. _____

Check box for G.I. Bulletin on Educational Benefits

- Veteran
- Active Duty

MAIL TODAY!

CIRCLE 8 ON FREE INFORMATION CARD

NEW SUPER LONG PLAY TAPE RECORDERS

12 Hour Model — \$105.00*

Modified Panasonic Slimline, high quality, AC-DC Recorders provide 6 continuous hours of quality recording & playback on each side of cassette for a total of 12 hours. Built-in features include:

- Voice level control
- Digital counter etc. TDK DC 120 Cassette Furnished.



PHONE RECORDING ADAPTER

Records calls automatically. All Solid state connects to your telephone jack and tape recorder. Starts recording when phone is lifted. Stops when you hang up.

\$24.50*
FCC APPROVED

VOX VOICE ACTIVATED CONTROL SWITCH

Solid state. Self contained Adjustable sensitivity. Voices or other sounds automatically activate and control recorder. Uses either recorder or remote mike.

\$24.95*

*Add for ship & hdlg. Phone Adapter & Vox \$1.50 ea. Recorders \$4.00 ea. Cal. Res. add tax. Mail order. VISA, MIC, COD's OK. Money Back Guarantee. Free data avail., Dealer Inquiries invited. Free data.

AMC SALES INC. Dept. 9355 Lubec
St. Box 928 Downey, CA 90241
Phone (213) 869 8519

CIRCLE 6 ON FREE INFORMATION CARD



Did You Get Your Free Catalog?

IF YOU HAVEN'T SEEN THE FREE MARK V ELECTRONICS CATALOG? HURRY UP! YOU'LL FIND EVERYTHING SUITABLE AND ESSENTIAL FOR FACTORIES, SCHOOLS, PROFESSIONALS AND ENTHUSIASTIC AMATEURS. OVER 60'S OF ASSEMBLES AND KITS WITH DIFFERENT LEVEL OF DIFFICULTY FOR KIT ASSEMBLY.

BEGINNERS: 6WX2 STEREO MINI AMP., LIGHT CONTROLLER, BATTERY FLUORESCENT LIGHT DRIVER, AND MORE.

INTERMEDIATE: 4 1/2 D. P. M., 0-50V 3A POWER SUPPLY, 120W MOSFET POWER AMP. AND MORE.

PROFESSIONALS: 1.2GHZ FREQ. COUNTER, 300W HQ AMP., 4680W 4 CHANNEL PRO. COLOR LIGHT CONTROLLER, AND MORE.

ANYWAY, THE SELECTION IS INCREDIBLE, THE VALUES ARE EVEN BETTER. AFTER ALL, ASK FOR YOUR OWN COPY TODAY AND YOU'LL HAVE MORE THAN A CATALOG, MORE THAN A REFERENCE.

YES, PLS SEND ME A COPY OF THE ALL-NEW FREE MARK V CATALOG.

NAME _____
ADDRESS _____
CITY _____ STATE _____ ZIP _____

MARK V ELECTRONICS INC.
8019, EAST SLAUSON AVE, MONTEBELLO CA90640

HANDS-ON ELECTRONICS

12 CIRCLE 18 ON FREE INFORMATION CARD

LETTERBOX

to one of our articles. Of course, sometimes there's just no way for us to help. We lack the resources to track down every component or piece of equipment ever made, or to track down specialized circuits to do specific jobs. That's why we've established the "Haves and Needs" section of Letter Box. Questions of that nature are published there as space permits. Hopefully, one of our readers will have the information you seek, and will share it with you by return mail.

Another "question" we often have difficulty with is: "It doesn't work!" There are a bunch of reasons why a particular circuit or project won't function when first turned on. Those include poor soldering, faulty printed-circuit boards, misoriented components, bad components, wiring mistakes, and, of course, circuit errors and typographical mistakes on our part. When you write, if you could include specific details or what the circuit does or doesn't do, including, if possible, voltage readings at various appropriate points, and what steps you have taken to get the project to operate, it will help us greatly in helping you get things in working order.

Helping Hand

I have been receiving your magazine now for several months, and enjoy it very much. I especially like the articles you run on theory and applications; and of course I like the projects. And I appreciate the fact that you don't just look at one area of electronics. I have been in the field for 22 years, and I know that there is more to electronics than the digital circuits that some magazines seem to exclusively feature. Keep up the good work.

Now to the real reason I wrote. In the July issue of **Hands-on Electronics** you published a letter from J.M. of Fresno, CA. He wanted to pursue a 2nd-Class Radiotelegraph License. A book that may be helpful is *Electronic Communication* by Robert Shrader; it is published by McGraw-Hill. That book contains a chapter devoted to radiotelegraph that J.M. will find useful in his studies.

As for the code part of the exam, check out some of the amateur-radio code-training tapes and records. Though I don't know off-hand what the code requirements are for the 2nd-Class Ra-

diotelegraph ticket, those learning aids will give you practice sessions for up to at least 20 words-per-minute.

Good luck to J.M. in his pursuit of the license.

—W.C.P. Georgetown, TX

Thanks for taking the time out to help a fellow reader. Your lead may just be the one that sends J.M., and perhaps others, on the road to success.

Part Hunting

I love your magazine and recently sent away for a subscription so that I will never again miss an issue.

I have a problem, however, that I hope you can solve. I am building the Wind Witcher that appeared in the February 1988 issue for my Mother. Unfortunately, I have had a problem finding three of the parts. Those are D1, the 1N4734 Zener diode; U1, the MC3401 quad op-amp; and C6, the 47- μ F, 100-WVDC Mylar capacitor.

I hope you can help me find those parts. My Mother has grown curious about my tinkering—she knows I'm building something, she just doesn't know what!

—L.J., Beavercreek, OH

First things first, C6 should be a 0.47- μ F unit (there is a typographical error in the Parts List; it is noted correctly in the schematic). Mylar is a trade-name for polyester; as a result, you will see Mylar units listed as polyester ones in most parts catalogs.

Second, you can use a National LM3401 as a direct replacement for the Motorola MC3401 listed; the National unit is a lot easier to find.



"Boy, You're right - - - you can't tell what a guy looks like by the way he sounds on the radio!"

Those two components, as well as the Zener diode, are available from one of our advertisers, Digi-Key (P.O. Box 677, Thief River Falls, MN 56701).

Incidentally, it's not unusual to have difficulty finding parts locally when you attempt to build electronics projects. Often, the only way to go is to become acquainted with the many outstanding mail-order companies that cater to the hobbyist market; many of them advertise their wares in the pages of this magazine. Use the Free Information Card to get catalogs from the companies that interest you; that's what it's there for!

Laptops Forever

I have to take exception to your comments on laptop computers (Which Way Did They Go; Editorial, June 1988). I'm a technician who works for a dealer in Colorado and my *only* MS-DOS computer is a Toshiba 1100+. I found that by having a laptop that I can cart around, I use my computer a lot more.

As far as the screen goes, I find it to be no real problem. Some of the early screens were definitely terrible. But even if you can't handle today's twisted-

crystal LCD's, the new backlit LCD screens are a real pleasure.

Although I know many people who leave disks in their laptops, most of the manufacturers recommend that you remove the disk before transporting your computer. That would have solved your problem of lost disks. An even better solution would be to use a model with a built-in hard disk. And at least one laptop, the Toshiba 1000, can be configured with 768K of battery backed-up RAM.

Also, have you been living in a cave? Articles on the problems of using modems with motel/hotel-room phones have been around for years.

Finally, about your complaint about the prices dropping: Do you remember the cost of the original IBM PC? Do you even own a computer, or are you waiting for the price to drop to \$9.95?

Sure a full-blown AT or 386 desktop machine is a real pleasure to use, but I am a reader of "the magazine for the electronics activist." I can be a lot more "active" with my little laptop.

I can't wait to see what manufacturers put a handle on next!
—S.F., Aspen, CO

Everyone's entitled to their likes and dislikes. If your laptop serves your needs, and it appears that it does, then it's the perfect machine for you. In the final analysis, that's the only thing that matters.

Haves and Needs

I am trying to locate a schematic for an older radio. It is an Air King model 4602-B. I tried to contact the present-day Air King Company, which is located in Chicago, but they have no information on radios, and may very well not be the same company as the one that manufactured my unit.

Norm Winquist
C/O 3761 Craigmillar Ave.
Victoria, British Columbia
Canada, V8P 3H2

I am trying to locate an AY-3-1350 Melody Synthesizer IC. That General Instruments device was carried by Radio Shack a few years ago, but is now discontinued. Anyone have any ideas for an alternate source?

Elias M. Raffoul
4301 Lois
Dearborn, MI 48126

NIGHTMARES?



You'll have nothing but sweet dreams when you order from MCM Electronics!

If you've been losing sleep because you can't get the electronic parts and components you need — when you need them — you haven't been dealing with MCM Electronics! Our all-new, expanded Catalog contains nearly 11,000 items, including lots of new test equipment at competitive prices you'll really appreciate. And, virtually every item is in-stock and ready to be shipped within 24 hours! Order your **FREE** copy today and get set for the "sweet dreams" you really deserve!

For your **FREE** copy, call TOLL-FREE

1-800-543-4330

In Ohio, call 1-800-762-4315

In Alaska or Hawaii, call 1-800-858-1849

600 NEW ITEMS!



MCM ELECTRONICS

858 E. CONGRESS PARK DR
CENTERVILLE, OH 45459-4072

A PREMIER Company

SOURCE NO. HO-18



NEW PRODUCTS

Micro Probes

Minitool's Micro Probes are hand-held micro-electrodes specifically designed for testing micro-circuits and miniature electronic equipment. The Micro Probes, with interchangeable handles, are ideal for testing under a microscope.

Micro-Probe handles and tips are fully insulated. The handles are supplied with lightweight, flexible, color-coded lead wire, and standard banana plugs. Probe tips are available in straight or bent configuration. They come in steel or tungsten, with a standard 0.5-mm diameter. The tungsten probes have 5- μ m radii. An audible beeper is also available.



CIRCLE 40 ON FREE INFORMATION CARD

Single probe handles, MPH-1B (black termination) and MPH-1R (red termination), retail for \$12.95 each. The straight steel Micro Probe tip, MPT-01SS, sells for \$8.75, and the bent steel tip, MPT-01BS, for \$8.95. The straight tungsten tip, MPT-02ST, is priced at \$12.25, and the bent tungsten tip, MPT-02BT, is \$13.25. The audible beeper costs \$9.95. For more information, contact Minitool, Inc., 1334-F Dell Avenue, Campbell, CA 95008; Tel. 408/374-1585.

Palm-Sized Modems

If you use portable or laptop computers, you need a modem that's just as mobile. The *Black Box Tote-A-Modem* fits into a shirt pocket or briefcase and is battery-operated. Available in either 1200 bps (\$199) or 2400 bps (\$359), the modem is full Hayes AT Command Set compatible and provides auto-dial/auto-answer, pulse and tone dialing, and



CIRCLE 41 ON FREE INFORMATION CARD

non-volatile storage of up to 20 commands.

Tote-A-Modem is powered by its own internal nine-volt battery. An optional (\$6.95) AC adapter allows use of an external power supply. The modem will work with practically any asynchronous computer equipped with an RS-232 serial port. A standard RJ-11 modular jack is provided for direct phone line connection, as is an acoustic adapter that broadens the modem's use to include phone booths, hotel rooms and many PBX systems. The acoustic adapter lets you use Radio Shack acoustic cups which provide full duplex operation at both 300 and 1200 bps.

For more information about Tote-A-Modem and hundreds of other quality data communications and computer devices write for your free copy of the:



"We handle the largest spreadsheet in the business!"

BLACK BOX Catalog, P.O. Box 12800, Pittsburgh, PA 15241; Tel. 412/746-5500.

Bookshelf Loudspeaker

Infinity Systems, Inc. announces the SM 80, the first bookshelf loudspeaker in the Studio Monitor Series. Like the other models in the line, the SM 80 is designed to deliver clarity and dynamic range without the need for high-power electronics. Utilizing as little as 10 watts of power, the efficient, compact SM 80 can generate concert-hall sound levels ideal for a wide range of contemporary recordings.



CIRCLE 42 ON FREE INFORMATION CARD

The SM 80 incorporates an eight-inch polypropylene coated woofer that is enclosed in a precisely tuned, bass-reflex designed cabinet with a vinyl finish. Infinity's woofer offers much of the linearity of pure polypropylene and the efficiency of paper, but without paper's sonic colorations. Constructed of polypropylene foam, a one-inch Polycell tweeter provides excellent dispersion, musically and flat response to 27 kHz. The SM 80 carries a suggested retail price of \$219.00 each (\$438/pair). Infinity Systems, Inc., 9409 Owensmouth Avenue, Chatsworth, California 91311; Tel. 818/709-9400.

PS/2 5.25-Inch Floppy

Dolphin Systems is selling the *Matchmaker*, a 360 KB, 5.25-inch, external floppy-disk subsystem for the IBM Personal System/2 family of computers. Com-



CIRCLE 44 ON FREE INFORMATION CARD

patible with all models from the Model 25 to the Model 80, the Matchmaker provides an efficient and economical solution to the problem of porting software and data from existing personal computers to the new PS/2 machines.

PS/2 machines may run programs directly from the Matchmaker, or programs may be copied from the Matchmaker to the system hard disk or internal 3.5-inch floppy disk drive, for later use by the PS/2.

The Matchmaker has a formatted capacity of 360 KB and an average access time of 81 ms. Weighing in at 3.9 lb, it measures 2 x 6 x 10 inches. The Matchmaker operates with IBM PC-DOS 3.2 or higher and carries a one year warranty.

Suggested list price for the Matchmaker is \$349. For further information please contact Dolphin Systems, 603-B E. Alton Ave., Santa Ana, CA, 92705; Tel. 714/546-6938.

PC-Interface Breadboard

Global Specialties PB-88/4 offers everyone, from PC hackers to professional computer circuit designers, a convenient way to prototype or experiment with IBM PC-compatible interfaces.

With a special buffered plug-in card and 60 conductor cable that connects right to any IBM compatible PC, the PB-88/4 brings all PC bus signals to labelled solderless sockets and provides more than 3,300 breadboard contact points.



CIRCLE 45 ON FREE INFORMATION CARD

Power is supplied by the host computer and is switchable from the front panel with LED "on" indicator. The breadboard's dimensions are 6" x 13" x 11.5". The PB-88/4 and all Global instruments, logic test and solderless breadboarding products can be purchased direct from the manufacturer and are included in Global's 1988 Electronic Testing and Prototyping Equipment catalog. To obtain a copy, contact Global Specialties, P.O. Box 1405, New Haven, CT 06505; Tel. 800/345-6251 or 800/445-6250 in Connecticut.

Audio Rack System

Soundesign's Model 5998P88 Audio Rack System was designed for consumers who want both a quality sound system and an attractive piece of furniture. The rack's traditional look—walnut-styled vinyl veneer finish on a double-door wood cabinet, with a tape-storage drawer and lift-up lid over the turntable—will complement the decor of virtually any room. The audio system includes dual-cassette decks, an AM/FM stereo receiver with wireless remote control, a graphic equalizer, a semi-automatic turntable, two tower speakers, and a programmable clock/timer.

The tape decks feature noise-reduction controls, providing clear sound during tape playback. Tape dubbing, from B to A, can be done in normal or high-speed mode, and the built-in synchrostart feature simplifies recording. Users have the option of listening to another program source while dubbing.

The tuner/amplifier has 12 watts of power per channel and a five-band graphic equalizer. It uses PLL MPX circuitry for improved FM stereo separation, and its built-in AFC and ceramic filter give better FM reception. Other features included are a slide-balance control and an LED mute indicator. The accompanying remote control has function buttons for power, mute, and volume control.

The Model 5998P88 also includes a programmable digital clock/timer with A.M., P.M., alarm, and sleep indicators. The user can program up to 59 minutes, to fall asleep or wake up to music. The timer can also be used to program a specified time for tape playback, recording, or playing the radio. By pushing the auto-off switch, that function will repeat on a daily basis.

The semi-automatic turntable has two speeds, bi-directional cue/pause control,

FREE Heathkit[®] CATALOG



Featuring superior quality electronic products in kit and assembled form. Innovative home products, test instruments, self-study electronics courses. Challenging and educational kits for first-time as well as seasoned builders. Quality ready-to-use electronic products for homeowners, sports enthusiasts and professionals. All from Heath Company, a leader in the changing electronics market.

Send NOW for your **FREE** Heathkit Catalog.

Send to:
Heath Company, Dept. 107-692
Benton Harbor, Michigan 49022

108 full-color pages packed with the latest in high quality electronic products

Heathkit[®]
 Heath Company
A subsidiary of Zenith Electronics Corporation

CL-792

Name _____
 Address _____
 City _____
 State _____ Zip _____

Be an FCC LICENSED ELECTRONIC TECHNICIAN!



No costly School. No commuting to class. The Original Home-Study course prepares you for the "FCC Commercial Radio-telephone License". This valuable license is your "ticket" to thousands of exciting jobs in Communications, Radio-TV, Microwave, Computers, Radar, Avionics and more! You don't need a college degree to qualify, but you do need an FCC License.

No Need to Quit Your Job or Go To School
This proven course is easy, fast and low cost! **GUARANTEED PASS** — You get your FCC License or money refunded. **Send for FREE facts now. MAIL COUPON TODAY!**

COMMAND PRODUCTIONS

FCC LICENSE TRAINING, Dept. 203
P.O. Box 2824, San Francisco, CA 94126
Please rush FREE details immediately!

NAME _____
ADDRESS _____
CITY _____ STATE _____ ZIP _____

AMAZING SCIENTIFIC & ELECTRONIC PRODUCTS

PLANS—Build Yourself—All Parts Available in Stock

- LC7—BURNING CUTTING CO₂ LASER \$ 20.00
- RUB4—PORTABLE LASER RAY PISTOL 20.00
- TC01—3 SEPARATE TESLA COIL 20.00
- PLANS TO 1.5 MEV 20.00
- K0G1—ION RAY GUN 10.00
- GR41—GRAVITY GENERATOR 10.00
- EM11—ELECTRO MAGNET COIL GUN/LAUNCHER 6.00

KITS

- MFT3K—FM VOICE TRANSMITTER 3 MI RANGE 49.50
- VWP7K—TELEPHONE TRANSMITTER 3 MI RANGE 39.50
- B1C3K—250 00 VOLT 10-14" SPARK TESLA COIL 199.50
- LHC2K—SIMULATED MULTICOLOR LASER 39.50
- BLS1K—100 000 WATT BLASTER DEFENSE DEVICE 69.50
- ITM1K—100 000 VOLT 20" EFFECTIVE RANGE INTIMIDATOR 69.50
- PSP4K—TIME VARIANT SHOCK WAVE PISTOL 59.50
- PTK1K—SPECTACULAR PLASMA TORNADO GENERATOR 149.50
- MVIPIK—SEE IN DARK KIT 199.50

ASSEMBLED

- PTV1K—SPECIAL EFFECT VISUAL PLASMA GENERATOR FOR GLOBES NEON TUBING ETC \$59.50
- B1C10—50 000 VOLT—WORLD'S SMALLEST TESLA COIL 49.50
- LG40—1MW HeNe VISIBLE RED LASER GUN 249.50
- TAT30 AUTO TELEPHONE RECORDING DEVICE 74.50
- GPV10—SEE IN TOTAL DARKNESS IR VIEWER 349.50
- LIST10—SNOOPER PHONE INFINITY TRANSMITTER 169.50
- IPG70—INVISIBLE PAIN FIELD GENERATOR—MULTI MODE 74.50

• CATALOG CONTAINING DESCRIPTIONS OF ABOVE PLUS HUNDREDS MORE AVAILABLE FOR \$1.00 OR USE OUR PHONE FOR "ORDERS ONLY" 603-673-4730

PLEASE INCLUDE \$3.00 PH ON ALL KITS AND PRODUCTS PLANS ARE POSTAGE PAID. SEND CHECK, MO, VISA, MC IN US FUNDS

INFORMATION UNLIMITED
P.O. BOX 716 DEPT. HO AMHERST, NH 03031



CIRCLE 46 ON FREE INFORMATION CARD

finger lift, and tone-arm lock. The two-way speaker system features eight-inch woofers, three-inch tweeters, and an electronic crossover network.

The suggested retail price for Model 5998P88 is \$299.00. For further information, contact Soundesign Corporation, Harborside Financial Center, 400 Plaza Two, Jersey City, NJ 07311.

Sound Level Meter

The Brunelle Model 39 is a hand-held sound level meter. It can be used to measure noise levels of factory equipment, street traffic, and sound systems.



CIRCLE 43 ON FREE INFORMATION CARD

It can also be used to check the noise levels of machinery and electrical appliances, such as air conditioners, motors, and ventilation systems. Another practical application is the measurement of ambient-noise levels in offices and factory work areas.

The Model 39 covers the 85- to 115-dB OSHA range. One-switch operation ensures ease-of-use. The unit is powered by a 9-volt battery.

Complete with carrying case and instruction manual, Model 39 costs \$119.99. For more information, contact: Brunelle Instruments Inc., P.O. Box 745, Newport, VT 05855-0745.

Portable Pattern Generator

The Model LCG-412B, a battery-operated, portable pattern generator, fills the need for a precision NTSC signal source for field adjustments of VTRs, VCRs, large-screen TV receivers, and monitors. The hand-held LCG-412B is also convenient to use for video-system field checks, as well as for bench operations.

Measuring only 3-1/8 x 6-3/4 x 3-3/8 inches, the unit weighs less than 14 ounces, including the 6 AA cells required for power. It features full-field 75% color bars, dot, crosshatch, and 100% white, red, green, and blue rasters.



CIRCLE 47 ON FREE INFORMATION CARD

Along with 1-volt peak-to-peak video output into a 75-ohm load, the LCG-412B features RF output on all U.S.-broadcast VHF and UHF channels. The RF output has on-off switchable FM sound carriers with internal 1-kHz modulation.

The LCG-412B carries a suggested retail price of \$385.00. For more information, contact *Leader Instruments Corporation*, 380 Oser Avenue, Hauppauge, NY 11788; Tel. 800/645-5104.

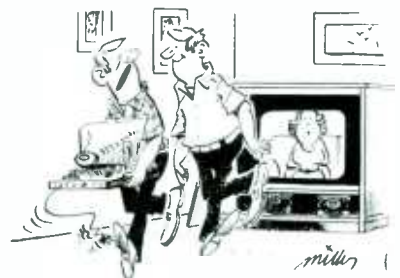

"I'll show you how to connect your computer to your TV set!"

Test Clips

Pomona Electronics' Minipincer test clips are designed to provide test-point contact for standard DIP ICs and other miniaturized electronic components. The Minipincer clip can be attached to a selected test point by a specially designed, pincer-type contact. Pincer contacts are made of gold-plated phosphor bronze.

The test clip is capable of grasping the individual legs of DIPs, .025 square pins, miniaturized components, and PC-board edges. The Minipincer's body is made of glass-filled nylon for maximum insulation value.

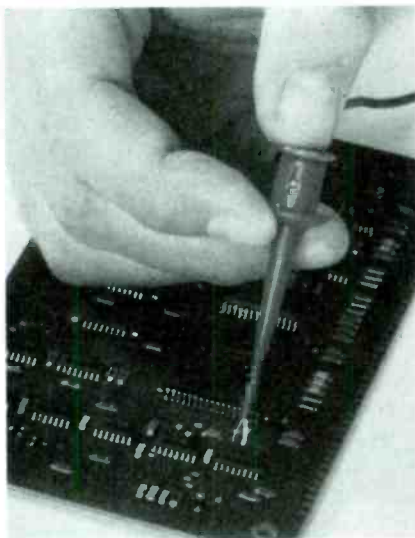

CIRCLE 48 ON FREE INFORMATION CARD

Seven different models are currently available. There are two models of patch cords—clip-to-clip, and clip-to-stacking-banana-plug; two cable assemblies—BNC (Male)-to-clip, and double-banana-plug-to-clip; a molded breakout with BNC (Female)-to-clip; a do-it-yourself clip; and a clip with a .025 square pin.

Suggested retail prices range from \$1.50 for a do-it-yourself clip to \$15.45 for the most complex two-cable assemblies. The complete line of Minipincer test clips and assemblies is described and illustrated in the 1988 Pomona Electronics Catalog, available at no charge from ITT Pomona Electronics, 1500 E. Ninth St., Pomona, CA 91766.

External Floppy Disk Subsystem for Laptop Computer

If you use a laptop computer, chances are you also have a desktop computer—and you need an easy means to copy files between the two. Dolphin Systems has introduced the Matchmaker Plus to address that need.

Matchmaker Plus is a 5-1/4-inch ex-



CIRCLE 81 ON FREE INFORMATION CARD

ternal floppy-disk subsystem for the Toshiba 1100+ laptop computer. It has a formatted capacity of 360K and an average access time of 81 ms. It operates with MS-DOS 3.2 or higher. At 3.9 pounds and measuring only 2 x 6 x 10 inches, it is lightweight and small enough to be carried around with the laptop, if necessary.

The Matchmaker Plus provides a convenient way to port software between the Toshiba laptop and standard desktop personal computers. It carries a list price of \$399.00. For further information on Matchmaker Plus—and on the original Matchmaker for IBM PS/2s—contact Dolphin Systems Technology, 603-B E. Alton Ave., Santa Ana, CA 92705.

PC Etch Resist Set

Using the DE-973 Direct Etch set, a circuit designer can make a high-quality PC Board without formal artwork. The set contains 69 different sheets of plastic etch-resist patterns that transfer by direct pressure onto a copper-clad circuit board. Patterns include DIPs; "D," edge-card, and DIN connectors; TOs; .050-inch to 0.250-inch donuts; transistors; .014-inch to 0.125-inch wide traces; and a wide range of surface-mount patterns.

To make a circuit, patterns and donuts are rubbed down with a spoon bur

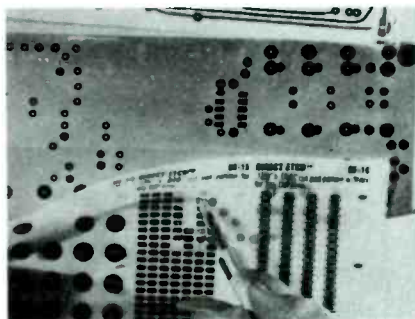

CIRCLE 82 ON FREE INFORMATION CARD

The Professional Meter for Personal Use.



The standard of the industry is setting a new standard for home use as well.

The Fluke 77 multimeter is ideal to test and repair anything electrical: home wiring, appliances... even your car. It's inexpensive, simple to operate and filled with professional features. Made in the U.S.A. and backed by a 3-year warranty, the new Fluke 77 is the world's first handheld meter to combine analog and digital displays.

For a free brochure or the distributor nearest you, call toll-free 1-800-44-FLUKE, ext. 33. Or write John Fluke Mfg. Co., Inc., P.O. Box C9090, Everett, WA 98206.

FROM THE WORLD LEADER IN DIGITAL MULTIMETERS.

FLUKE 73	FLUKE 75	FLUKE 77
\$79†	\$119†	\$149†
Analog/digital display	Analog/digital display	Analog/digital display
Volts, ohms, 10A, diode test	Volts, ohms, 10A, mA, diode test	Volts, ohms, 10A, mA, diode test
Autorange	Audible continuity	Audible continuity
0.7% basic dc accuracy	Autorange/range hold	"Touch Hold" function*
2000+ hour battery life	0.5% basic dc accuracy	Autorange/range hold
3-year warranty	2000+ hour battery life	0.3% basic dc accuracy
	3-year warranty	2000+ hour battery life
		3-year warranty
		Multipurpose holster

*Patent Pending

†Suggested U.S. list price.



© 1988 Fluke

Ad No. 0381-F/0

CIRCLE 12 ON FREE INFORMATION CARD

ELECTRONIC COMPONENTS CATALOG

... yours FREE by dialing

1-800-992-9943

Call Today for your FREE subscription to the latest Mouser Electronics Catalog. Contains 192 pages featuring over 17,000 in-stock, quality electronic components. ..PLUS..Mouser's proven service and prompt delivery. Outside U.S.A., Send \$2.



MOUSER ELECTRONICS
2401 Hwy 287 North
Mansfield, Texas 76063
DISTRIBUTION CENTERS COAST-TO-COAST

CIRCLE 13 ON FREE INFORMATION CARD



CHEMICAL SOLUTIONS

FREE CHEMTRONICS CATALOG!

Comprehensive new source for over 200 products used in electronic manufacturing and field service. Precision cleaning agents, flux removers, bulk solvents, circuit refrigerants, precision dusters, non-residual wipers, foam swabs, premoistened pads/swabs, antistatic compounds, conformal coatings, lubricants, adhesives, desoldering braids, rosin core solder and solder masking agents. Complete with technical specifications and application guide.



Chemtronics Inc.
681 Old Willets Path
Hauppauge, N.Y. 11788
516-582-3322

CIRCLE 17 ON FREE INFORMATION CARD

NEW PRODUCTS

nisher or ball point. Next, connecting traces are placed down by cutting to length and transferring. The final circuit is spray- or tank-etched in any standard etchant. Then the resist is removed by soaking the board in mineral spirits and rubbing with a soft cloth.

The time-consuming steps of changing the master art and refabricating in the model shop or through an outside vendor are eliminated when Direct Etch is used. The system is valuable for optimizing RF and microwave designs where wavelengths approach circuit dimensions, and in high-impedance circuits where noise and interference present trouble. With Direct Etch, technicians and engineers can now make a quick prototype in situations where a printed circuit would not ordinarily be economically feasible.

The DE-973 Direct Etch set costs \$34.95. Each pattern is available separately as a refill set of two sheets for \$2.00. For further information, contact *The DATAK Corporation*, 3117 Paterson Plank Road, North Bergen, NJ 07047.

Programmable Tuner

The *Revox B260 Tuner* was engineered for optimum performance in high-density reception areas, with excellent stereo separation and imaging. Six filters are used in the IF circuitry in the demodulation system, to improve selectivity. Coward filters are used to remove unwanted sidebands and extraneous frequencies, to provide a clearer signal.

The B260 offers a variety of programming options, with 60 FM presets that can be divided into six subgroups. Users can access and scan one selected group of station presets. The auto-tune feature simplifies preset programming by automatically assigning the next available preset location at the touch of a button. The fluorescent display indicates both frequency and alphanumeric characters.

Operation can be tailored to the indi-

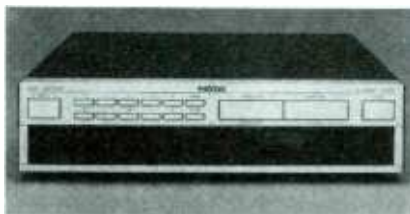

CIRCLE 83 ON FREE INFORMATION CARD

vidual user's needs and tastes. Uniform volume can be achieved by programming the output level of each station. Optimum antenna settings for each station can be programmed, as well as two levels of blend and mono. All programming controls are placed behind a glass door on the front panel, to separate them from operating controls.

The low-profile B260 tuner measures 17-1/8 x 4-1/3 x 13 inches, and retails for \$2,000.00. More information is available from *Revox Division, Studer Revox America, Inc.*, 1425 Elm Hill Pike, Nashville, TN 37210.

Gang-Programming Modules

Stag's 40M102 and 41M102 modules can be used to gang program 40-pin DIP megabit EPROMs. Those two modules, for the *PP40 series* of programmers, are designed to handle current 1-megabit EPROMs, and future generations of 2-, 4-, and 8-megabit EPROMs.

The 40-pin devices offer 16-bit wide paged data, reducing the number of devices required in 16- and 32-bit processor environments and saving valuable board space. There is no need for set programming, as is the case with 8-bit devices. The 40M102 and 41M102 will automatically re-format data downloaded from 8-bit development systems to 16-bit.



CIRCLE 84 ON FREE INFORMATION CARD

The modules, with the PP40-series programmers, retain the full features of gang programmers, including master-slave copying of up to eight devices simultaneously. With the *PP41*, data can be downloaded from a host computer via dual RS232 interfaces. The PP41's features also include editing functions, remote-control operations, and Stag Com 1 software package, which provides full-screen editing and control from an IBM-PC or equivalent.

The PP40 and PP41 programmers, with large, 16-character alphanumeric display provide information on operating mode, device type, and data val-

GET THE KNOW-HOW TO SERVICE EVERY COMPUTER ON THIS PAGE.

Learn the Basics the NRI Way—and Earn Good Money Troubleshooting Any Brand of Computer

The Department of Labor ranks computer service high on its list of top growth fields, with accelerated demand creating more than 30,000 new jobs within the next 10 years.

You can cash in on this opportunity—either as a full-time corporate technician or an independent service-person—once you've learned all the basics of computers the NRI way. NRI's practical combination of "reason-why" theory and "hands-on" building skills starts you with the fundamentals of electronics, then guides you through advanced electronic circuitry and on into computer electronics. You also learn to program in BASIC and machine language, the essential languages for troubleshooting and repair.

Total Computer Systems Training, Only From NRI

No computer stands alone... it's part of a total system. To really service computers, you have to understand computer systems. And only NRI includes a powerful computer system as part of your training, centered around the new, fully IBM-compatible Sanyo 880 Series computer.

You start with the step-by-step assembly of your Sanyo 880 computer. You build and test the "intelligent" keyboard, install the power supply and 5 1/4" floppy disk drive, and interface the high-resolution monitor. But that's not all. You go on to install a powerful 20 megabyte hard disk drive—today's most-wanted computer peripheral, now included as part of your total systems training.

With your computer now up and running, you're ready to use the valuable software that completes your total computer system.

No Experience Needed, NRI Builds It In

You get practical, hands-on experience

IBM is a Registered Trademark of IBM Corporation.
Epson is a Registered Trademark of Epson America, Inc.
Apple and the Apple logo are Registered Trademarks of Apple Computer, Inc.
Compaq is a Registered Trademark of COMPAQ Computer Corporation.
© 1985 AT&T Technologies, Inc.

technical staff, ready to help you when you need it. You get it all from NRI!

Free 100-Page Catalog Tells More

Send the coupon today for NRI's big, 100-page, color catalog on NRI's electronics training, which gives you all the facts about NRI courses in Micro-computers, Robotics, Data Communications, TV/Video/Audio Servicing, and other growing high-tech career fields. If the reply coupon is missing, write to the address below.

NRI Schools,
McGraw-Hill Continuing Education Center,
3939 Wisconsin Avenue,
Washington, D.C. 20016.

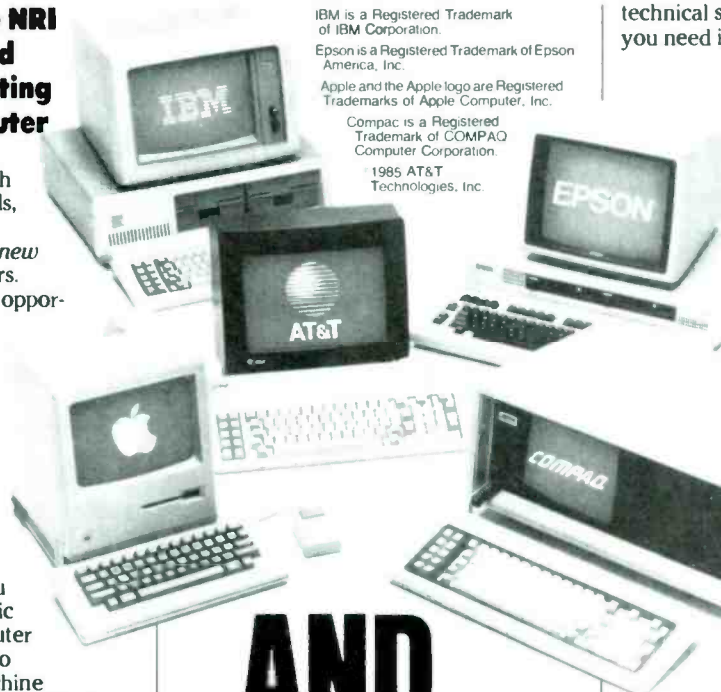

AND MORE!

that gives you the skills you need for success. You learn in your own home. No classroom pressures, no night school, no need to quit your present job until you're ready to make your move.

Your training is backed up by your personal NRI instructor and the NRI



Your NRI course includes: the IBM PC compatible Sanyo 880 computer with 256K RAM • high-resolution monitor • 360K, 5 1/4" floppy disk drive • 20 meg hard disk drive • "Intelligent" keyboard • NRI Discovery Lab for circuit design, tests • digital multimeter • digital logic probe • GW-BASIC, MS-DOS, WordStar, CalcStar software—and more.

SEND COUPON TODAY FOR FREE NRI CATALOG!

NRI SCHOOLS

McGraw-Hill Continuing Education Center
3939 Wisconsin Avenue, NW, Washington, DC 20016



For Career courses approved under GI Bill
 check for details.

CHECK ONE FREE CATALOG ONLY

- | | | |
|---|---|--|
| <input type="checkbox"/> Computer Electronics | <input type="checkbox"/> Electronic Design Technology | <input type="checkbox"/> Air Conditioning, Heating & Refrigeration |
| <input type="checkbox"/> TV/Video/Audio Servicing | <input type="checkbox"/> Industrial Electronics | <input type="checkbox"/> Small Engine Repair |
| <input type="checkbox"/> Robotics | <input type="checkbox"/> Communications Electronics | <input type="checkbox"/> Electrician |
| <input type="checkbox"/> Electronic Music Technology | <input type="checkbox"/> Basic Electronics | <input type="checkbox"/> Locksmithing & Electronic Security |
| <input type="checkbox"/> Satellite Electronics | <input type="checkbox"/> Bookkeeping and Accounting | <input type="checkbox"/> Travel Careers |
| <input type="checkbox"/> Digital Electronic Servicing | <input type="checkbox"/> Building Construction | <input type="checkbox"/> Telephone Servicing |
| | <input type="checkbox"/> Automotive Servicing | <input type="checkbox"/> Paralegal |

Name (Please print) _____ Age _____

Street _____

City/State/Zip _____ We'll give you tomorrow. Accredited by the National Home Study Council 1 R 098

ATTENTION! ELECTRONICS TECHNICIANS

EARN YOUR
**B.S.E.E.
DEGREE**
THROUGH HOME STUDY



Our New and Highly Effective Advanced-Placement Program for experienced Electronic Technicians grants credit for previous Schooling and Professional Experience, and can greatly reduce the time required to complete Program and reach graduation. No residence schooling required for qualified Electronic Technicians. Through this Special Program you can pull all of the loose ends of your electronics background together and earn your B.S.E.E. Degree. Upgrade your status and pay to the Engineering Level. Advance Rapidly! Many finish in 12 months or less. Students and graduates in all 50 States and throughout the World. Established Over 40 Years! Write for free Descriptive Literature

COOK'S INSTITUTE
OF ELECTRONICS ENGINEERING



4251 CYPRESS DRIVE
JACKSON, MISSISSIPPI 39212

CIRCLE 10 ON FREE INFORMATION CARD



DMR-45

4½ Digit Ruggedized Multimeter 30 Position Rotary with 5" High Contrast LCD Auto-Overrange and Auto Polarity Diode and Transistor Test ul Buzzer Data Hold and All AC-DC Ranges with Resistance 20 AMP Current Range

Under \$116.00

PS6CL

4 AMP Non Reg with 6 AMP Super Cigarette Lighter Attachment Auto Reset Circuit Breaker Meets All ul specs

Under \$28.00

Also avil Reg 10 AMP
Under \$60.00



COSC-10st

5" Single Track Triggered Oscilloscope Up to Date State of the Art 10 MHz Recurrent with XYZ Axis

Under \$310.00

RES-5

Resistance Decade/Substitution Box 999,999 OHMS in 6 Segments in 1 OHM steps Tolerance of Resistors ½% Under \$67.00

Available At Your Local Distributor,
Catalog House Or School Supply Company.

We Also Have Digital Multimeters, Dual Trace Scopes, Analog Multimeters, Sine & Square Wave Generators, Resistance Sub & Decade Box

EMCO ELECTRONICS

P.O. Box 327, Plainview, N.Y. 11803

Free Catalog

NEW PRODUCTS

ues. Extensive self-test checks are carried out automatically to ensure operational integrity. The programmers can detect faulty devices or connection errors during pre- and post-program tests. Status and errors are indicated by both the alphanumeric display and dual-colored LEDs.

The 40M102 and 41M102 cost \$675.00 each, from Stag Microsystems Inc., 1600 Wyatt Drive, Santa Clara, CA 95054; Tel. 800-227-8836.

Flat-Screen Monitor

Proton's VM-210, a 20-inch monitor with a flat, square screen, offers 400 lines of horizontal resolution. The quality power supply incorporated in the VM-210 limits overscan to only 5%, so more of the original broadcast image is shown on the screen.

Connection to an IBM-PC or compatible is facilitated by a nine-pin RGB input. The monitor is equipped with a pair of BNC connectors for use in professional applications. Another standard feature, the automatic-standby function, turns off the monitor two minutes after all video signals have ceased.



CIRCLE 85 ON FREE INFORMATION CARD

A three-watt-per-channel, 8-ohm, internal stereo amplifier and built-in speakers provide quality sound reproduction. To enhance the sound, Proton recommends adding the 314 Bi-Amplified Loudspeaker System.

The VM-210 monitor has a suggested retail price of \$649.00; the 314 speakers are \$299.00 a pair from Proton Corporation, 737 West Artesia Blvd., Compton, CA 90220.

Radar Detector/CB Combo

The Audiovox HP-100 Highway Patrol set combines the RX-2 radar detec-



CIRCLE 86 ON FREE INFORMATION CARD

tor with the MCB-16 mini 40-channel CB transceiver.

The RX-2, with dual-conversion superheterodyne circuitry, provides maximum range while discriminating between actual X- or K-band radar signals and false interference signals.

The CB features up/down channel selection and a digital-LED read out. A four-segment LED bar-graph indicates signal strength and output power. The MCB-16 has full-range rotary volume and squelch controls.

The HP-100 set has a suggested list price of \$230.00. For further information, contact Audiovox Corporation, 150 Marcus Blvd., Hauppauge, NY 11788.

Hand-Held Digital-Storage Oscilloscopes

The Tektronix T201 and T202 hand-held digital-storage oscilloscopes weigh less than two pounds each, but offer the features and performance of a full-size scope. Tektronix' T200 series oscilloscopes have two channels, dual-time base, 5-MHz bandwidth for repetitive signals and 2-MHz for single-shot signals, and a 20-MS/s sampling rate with 20-ns resolution. Flat-panel LCD technology and digital capabilities were used to achieve the scopes' small size.

Users can choose between two different oscilloscope designs. For those with previous oscilloscope experience, the T202 offers a traditional front panel that's divided into familiar functional sections. Those include separate sec-



"I hate to disturb him when he gets involved!"



CIRCLE 87 ON FREE INFORMATION CARD

tions for channel one and two controls, as well as triggering and other functions. Users who are more comfortable with left-to-right logical manipulations may prefer the calculator-like front panel of the T201.

Auto setup allows users to preset such parameters as timebase, sweep speed, trigger mode, and cursors, all with simple programming sequences. With the T200's digital-voltmeter and timer-counter capabilities, voltage levels and timing problems can be pinpointed quickly. Four common voltmeter measurements—true-RMS, DC, peak-to-peak, and ground-to-peak voltage—can also be made. Time and frequency measurements are accurate to better than 0.05%, with error indications displayed in percentage on the screen.

Time, voltage, and trigger information appear on the LCD display. There are two vertical and two horizontal cursors for each of two channels, for the accurate measurement of waveform characteristics.

The inherent digital-storage capabilities provide more standard features. Users can store up to nine front-panel settings in nonvolatile memory; frequently-used setups can be stored, and recalled as needed on service calls. With save-reference memory, as many as nine waveforms can be stored permanently in the scope. Waveforms acquired at the customer site can be analyzed later in the home office, and reference waveforms can be compared with captured ones when troubleshooting in the field.

Signal-processing capabilities provide more flexibility: Users can combine waveforms from different channels, signal process an input channel with a saved-

reference waveform, or combine two saved-reference waveforms.

The T201 and T202 come complete with battery pack, two probes, carrying case, manual, and audio-cassette training kit, and have a suggested list price of \$1995.00 each. For additional information, contact Tektronix, Portable Test Instruments Division, P.O. Box 1700, Beaverton, OR 97077; Tel. 1-800-426-2200.

Weather-Proof Speakers

True high-fidelity, weatherproof materials, contemporary styling, and a variety of mounting systems allow *Soundpipes* to deliver component-stereo sound in a wide variety of applications.

The 5-inch, two-way speaker system is housed in a unique enclosure to minimize sound coloration due to standing waves and diffraction. PVC-plastic housing, stainless steel hardware, and sealed plastic housing make *Soundpipes* impervious to moisture. They are ideally suited to poolside, patios and decks, and boats.

Soundpipes are attractive enough—and sound good enough—for indoor use as well. Each speaker features a 5-inch polypropylene cone woofer, 3/4-inch poly-



CIRCLE 89 ON FREE INFORMATION CARD

carbonate dome tweeter, optimized crossover design, and minimum diffraction enclosure. A nominal impedance of 8 ohms ensures against amplifier overload when *Soundpipes* are added to an existing speaker system. The frequency response, imaging, and low distortion produced by *Soundpipes* are comparable to those of larger, more expensive speaker systems.

The suggested retail price of *Soundpipes* is \$299.00 per pair. For further information about the speakers, contact the manufacturer: *Waterworks Acoustics*, 3365 Fenside Blvd., Alameda, CA 94501; Tel. 415-522-0374. ■

GOT A PROBLEM?

Like testing 16 logic lines simultaneously, economically?



Get The Solution:

- The AR-80LM Logic Monitor. Like 16 20 MHz logic probes.
- TTL and CMOS. Even pulse memory to catch that elusive glitch.
- ARI's AR-80LM. Because you deserve the best.



ADVANCED CUSTOM IC DESIGN
ALLOWS USE TO 20 MHz - LIKE
GETTING 16 LOGIC PROBES IN
ONE COMPACT PACKAGE



AMERICAN RELIANCE INC.
VALUE BEYOND MEASURE

9241E, VALLEY BLVD. ROSEMEAD, CA 91770
TEL: (818) 287-8400 (800) 654-9838

ARI manufactures a complete line of electronic test equipment, including EPROM, EEPROM, and PLD programmers, IC testers, Cable testers, DPMs, DMMs, and Logic testing devices. Call or write today for your free Brochure.

CIRCLE 20 ON FREE INFORMATION CARD

BOOKSHELF

How to Read Electronic Circuit Diagrams—2nd Ed. By Robert M. Brown, Paul Lawrence & James A. Whitson

For every hobbyist, student, or experimenter who wants to learn how to recognize electronic schematic symbols, understand how the components those symbols represent work, and accurately read schematic diagrams of electronic circuits—here is the ideal book.

The authors begin with a look at some common electronic components and their schematic symbols. Then, some simple electronic circuits are introduced, along with a variety of more specialized electronic components, such as transducers and indicating devices. More complicated solid-state devices like transistors, diodes, and integrated circuits are then explained, and vacuum tubes are covered.

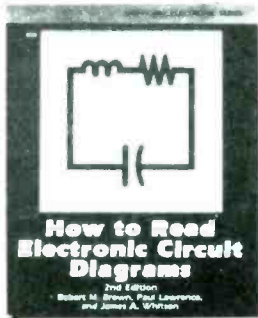

CIRCLE 98 ON FREE INFORMATION CARD

Through this self-teaching guide, readers will become proficient at reading block diagrams, exploded views, mechanical construction diagrams, and, finally, actual electronic schematic diagrams. All information is given gradually and painlessly, with new concepts building logically upon those explained before. As the material evolves into more complicated schematics, readers will find themselves easily identifying relays, fuses, resistors, and circuit breakers from the full-sized schematic diagrams pictured in the book.

For anyone who wants to learn how to read electronic circuit diagrams, this is the only book required. Extremely

well illustrated, with many photographs, it is both a valuable teacher and a handy reference for locating data on circuit symbols, terminology, and color coding. A glossary of terms and complete index round out the book.

How To Read Electronic Circuit Diagrams—2nd Edition order No. 2880, contains 224 pages costing \$12.95. To order contact Tab Books Inc., PO Box 40, Blue Ridge Summit, PA 17214; Tel. 717/794-2191.

IBM PS/2 Handbook By Richard Dalton

IBM's revolutionary Personal System/2 computers are redefining the personal computer market. Incorporating numerous technical breakthroughs, the PS/2 family sets new standards of excellence for personal computing.

Que's latest book, *IBM PS/2 Handbook*, contains a wealth of information to help readers better understand the PS/2 phenomenon. The text explores the following: features and capabilities of PS/2 Models 25, 30, 50, 60, and 80, new PS/2 technology, including the new system-board design, MCGA and VGA graphics, and Micro Channel Architecture, differences and similarities of the OS/2 and PC DOS 3.3 operating systems.

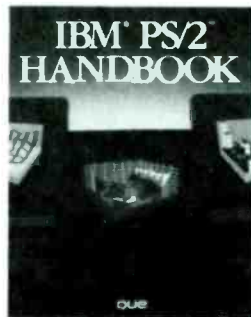

CIRCLE 94 ON FREE INFORMATION CARD

Anyone working with—or thinking of working with—PS/2 computers will benefit from the useful information presented in this book. Readers considering a PS/2 purchase can use the checklists at the end of key chapters to help

determine which machines best suit their needs. Recent PS/2 purchasers will learn how to realize the maximum potential of their systems. And all users will learn how to integrate PS/2's into existing PC environments—with a minimum of difficulty. The book contains 375 pages, costing \$19.95, and can be ordered from Que directly by dialing 800/428-5331.

Understanding Your Car Sound System By "Buck" Gregory L. Matlock

Each year, thousands of car-stereo systems and components are purchased by consumers with little practical knowledge of automobile sound systems. This book will help those consumers choose the best system for their needs, and get the most out of it once it's installed.

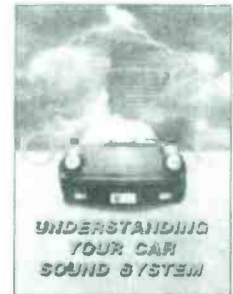

CIRCLE 90 ON FREE INFORMATION CARD

Starting with the basics, *Understanding Your Car Sound System* offers simple explanations of sound and acoustics before describing the actual components. It examines how those components work, how to operate them properly for maximum performance, and what options are available. The book continues with a detailed step-by-step installation guide, including a cross-referenced chart for domestic- and foreign-car installations. It covers how to care for a car-stereo system, and contains a glossary of terms.

Each section is fully illustrated, and ends with a short quiz to help the reader learn the material that is presented. The book is designed to allow the newcomer to car sound systems—and the more experienced consumer—to make informed

decisions when buying, and increase their understanding and enjoyment of car stereos.

Understanding Your Car Sound System contains 143 pages: suggested retail price is \$39.95; from Stereo Warehouse; 7500 Menaul NE, Albuquerque, NM 87110; Tel. 505-881-6028.

Getting the Most From Your Multimeter

By R.A. Penfold

A multimeter is one of the first pieces of test equipment purchased by most electronics hobbyists—and not just because it is one of the least expensive. When used properly, a multimeter can be one of the most-useful pieces of gear on the hobbyist's test bench. While other equipment can speed up the checking process in many cases, and is necessary for some tests, a multimeter and some thoughtful checking are sufficient in most testing situations.

This book is intended to teach the reader how the multimeter can be used effectively, and what its limitations are. Aimed at beginners with limited electronics experience, the book begins with

Getting The Most From Your Multimeter



CIRCLE 97 ON FREE INFORMATION CARD

the basics of analog and digital multimeters, including the relative merits of the two types. Descriptions of various methods of component checking follow. Tests for transistors, thyristors, resistors, capacitors, and diodes are included. The final section of the book covers such topics as circuit testing, discussing voltage, current, and continuity checks.

Using the simple component-checking and circuit-testing techniques presented, even a beginner should be able

to confidently tackle servicing of most electronic projects.

Getting the Most From Your Multimeter contains 102 pages. It is available for \$7.75, including shipping (order No. BP239), from Electronics Technology Today, P.O. Box 240, Massapequa, NY 11762.

Electronics Sourcebook for Technicians and Engineers

Edited by Milton Kaufman and Arthur H. Seidman

The *Electronics Sourcebook* is a condensed, softcover edition of the *Handbook For Electronics Engineering Technicians, Second Edition*. Designed to meet the day-to-day needs of electronics technicians, the sourcebook does not require an extensive background in engineering principles and techniques.

Filled with worked-out examples, explanations, and illustrations, the book uses practical applications to help engineers and technicians solve on-the-job problems. The *Electronics Sourcebook* covers fundamental topics in discrete circuits, and in analog and digital integrated circuits. The practical examples

ALL ELECTRONICS CORP.

*QUALITY PARTS CALL OR WRITE FOR A *DISCOUNT PRICES
FREE 52 PAGE CATALOG
WE HAVE OVER 4000 PARTS AVAILABLE!!

FULL WAVE BRIDGE RECTIFIERS

10 AMP 200 P.I.V.
5/8" SQUARE
CAT# FWB-1020

\$1.00 each • 10 for \$9.00

25 AMP RATING

1 1/8" SQUARE
metal epoxy filled case
200 P.I.V. \$2.50 each
CAT# FWB-251

400 P.I.V. \$3.00 each
CAT# FWB-254

600 P.I.V. \$3.50 each

ITT PUSH BUTTON

ITT MDPL series. 3/4" X 1/2" gray rectangular key cap. S.P.S.T. N.O. Push to close.

RATED:
0.1amp switching,
0.25 amp carry current. P.C. mount

CAT# PB-8 65c each
10 for \$6.00 • 100 for \$50.00

10 AMP SOLID STATE RELAYS



ELECTROL# S2181 CONTROL

Rated 5.5 to 10 Vdc (will operate on 3-32 Vdc)

LOAD:
10 Amp @ 240 Vac
2 1/4" X 1 3/4" X 7/8"

CAT# SSRLY-10B \$9.50 each

10 for \$8.50 each

QUANTITY DISCOUNT!
25 for \$7.00 each
50 for \$6.00 each
100 for \$5.00 each

XENON FLASH TUBES



3/4" long X 1/8" diameter
CAT# FLT-1 2 for \$1.00

OPTO SENSORS

TRW# OPB815 U shaped opto emitter and sensor unit.

CAT# OSU-3 2 for \$1.00

Clairex# CL1800W U shaped unit with flange mount.

CAT# OSU-2 75c each

PHOTO RESISTOR ASSEMBLY

Center-tapped photo resistor mounted in plastic case (can be easily removed). 700 ohms light, 36K dark, 1/4" diameter.

CAT# PR-4 \$1.00 each
10 for \$8.50

STORES:
LOS ANGELES
905 S. VERMONT AVE.
LOS ANGELES, CA 90006
(213)380-8000

VAN NUYS
6228 SEPULVEDA BLVD.
VAN NUYS, CA 91411
(818)997-1806

MAIL ORDERS TO:
ALL ELECTRONICS
P.O. BOX 567
VAN NUYS, CA 91408

TELEX: TWX-5101010163
ALL ELECTRONICS
FOREIGN CUSTOMERS
SEND \$1.50 POSTAGE FOR FREE CATALOG!!

TOLL FREE
800-826-5432
INFO: (818)904-0524
FAX: (818)781-2653

MINIMUM ORDER \$10.00
QUANTITIES LIMITED
CALIF. ADD SALES TAX
USA: \$3.00 SHIPPING
FOREIGN ORDERS INCLUDE SUFFICIENT SHIPPING.

HSC Halted specialties co.

Send for our Specials File!

Electronic Components & Test Equip.
Prototyping & Hobby Supplies
Computers, Lasers & Optics

DISPLAY PAGING RECEIVER

Designed for use in a radio paging system

- Dual conv. superhet 450 MHz crystal controlled receiver module (plug in module)
- Twenty character alpha-numeric LED display (ASCII Encoded) (ANSI character set)
- RCA CDP 1802 Processor based display mode controller
- Photoelectric "teletyp" unit

APPLICATIONS
Receiver module may be removed for other uses. Receiver should be re-installed for Ham Radio Use. (Possible to use for original application on Ham Bands. Terrific source of parts.

UNITS ARE COMPLETE BUT UNTESTED & SOLD "AS IS"

\$1995 INCLUDING SHIPPING.

PROJECT BOX W/FAN
3 1/2" x 7 1/2" x 9"
3" Fan
Perfect for mounting power supplies or building projects
Black Winkle Finish

\$995 W/Fan
\$195 W/O Fan

SWITCHING POWER SUPPLY—

IDEAL FOR DISK DRIVES—50 Watt—5V 4 AMP—12V 3 AMP—4" x 6" x 1 3/4"

\$29.95

ROBO-CAT

ROBOTICS HOBBYIST SPECIAL!

\$2995

IEEE 488 HARD DRIVE CONTROLLER
• \$7500+ compatible
• Manufactured by Zebec
• Great for the Experimenter

NEW RS-232 BREAK OUT BOX

- SWITCHABLE LINES
- LED INDICATORS
- PATCH TERMINALS & JUMPERS
- COMPACT SIZE

\$3195

ROBO-CAT

This top rated cat is perfect for the robot hobbyist. It is being offered in limited quantities at this special price. They are just what you need to control the mechanical cat. When you get it, you will be able to control the cat's movements.

Features:
• Can operate 90 meters of wire
• Can recognize the cat's location
• Battery powered (1.5" x 1.5")
• Red LED glowing light

\$4.95

MODULAR TELEPHONE JACK

- Standard 4 pin
- Nice Braun rfid feature
- Flush mounting

49c

DC CONVERTER

- 5 VDC to -12 VDC @ 85 mA

79c

RELAY

- 12 VDC
- SPST
- 5 Amp

75c

TRANSFORMER

- 18 VAC
- .75 Amp

50c

MINIMUM \$10 ORDER
QUANTITIES LIMITED.
CA RES. ADD SALES TAX

3060 COTTER RD., SANTA CLARA, CA 95051
CA RESIDENTS & INFO. TOLL FREE ORDER LINE
408-732-1573 800-4HALTED

TV, RADIO COMMUNICATIONS



◀ **BP91—INTRO TO RADIO DXING . . . \$5.00.** Everything you need to know about radio DXing and how you can get into this fascinating hobby area.

□ **BP155—INTL RADIO STATIONS GUIDE . . . \$6.95.** New edition lists station site, country, frequency. ERP provides for thousands of short wave radio stations. Nine sections cover a variety of broadcast services.



◀ **BP105—ANTENNA PROJECTS . . . \$5.00.** Practical antenna designs including active, loop, and ferrite types that are simple and inexpensive to build, yet perform well. Also included are antenna accessories.

□ **BP125—SIMPLE AMATEUR BAND ANTENNAS . . . \$5.00.** Shows how to build 25 antennas starting with a simple dipole and working on up to beam, triangle and even a mini rhombic.



◀ **BP132—25 SHORT-WAVE BROADCAST ANTENNAS . . . \$5.00.** Good antennas can be inexpensive. Here's 25 different ones ranging from a simple dipole, through helical designs to a multi-band umbrella.

□ **BP136—25 INDOOR AND WINDOW ANTENNAS . . . \$5.00.** If you can't put up a conventional antenna because of where you live, one of these 25 designs is likely to solve your problem and deliver great reception.



MAIL TO: **Electronic Technology Today Inc.**
P.O. Box 240
Massapequa Park, NY 11762-0240

SHIPPING CHARGES IN USA AND CANADA

\$0.01 to \$5.00 . . .	\$1.25	\$30.01 to \$40.00	\$5.00
\$5.01 to 10.00 . . .	\$2.00	\$40.01 to \$50.00	\$6.00
\$10.01 to \$20.00	\$3.00	\$50.01 and above	\$7.50
\$20.01 to \$30.00	\$4.00		

SORRY, No orders accepted outside of USA and Canada

Total price of merchandise . . . \$ _____
 Shipping (see chart) . . . \$ _____
 Subtotal . . . \$ _____
 Sales Tax (NYS only) . . . \$ _____
 Total Enclosed . . . \$ _____

Name _____
 Address _____
 City _____ State _____ Zip _____

BOOKSHELF

illustrating each topic can be applied to the reader's own problems. It shows the reader how to choose the proper resistor, capacitor, transistor, IC, or op-amp, and how to find current in, or voltage across, an element in DC and AC circuits.



CIRCLE 96 ON FREE INFORMATION CARD

Each of the 24 sections follows the same concise format, designed to help readers find information quickly and easily. Every section begins with a definition of terms and parameters, and a breakdown of the characteristics of components. An analysis of the basic and special functions is presented. Finally, detailed practical problems are followed by clearly worked-out solutions. Throughout each section, charts, tables, and illustrations further clarify the text.

This comprehensive volume contains up-to-date coverage of such topics as logic analyzers and signature analysis, microwaves, fiber optics, active filters, digital multimeters, microprocessors, power supplies, semiconductors, and oscilloscopes. It is useful as a reference, a refresher course, a training aid, or for a quick update on a specific subject.

Electronics Sourcebook for Technicians and Engineers has 624 pages. It costs \$22.95, and is published by McGraw-Hill Book Company, 1221 Avenue of the Americas, New York, NY 10020.

WordStar Quick and Dirty By Carol Horrar Ham

This no-nonsense guide to *WordStar* concentrates on teaching the basics of the most frequently required applications of that popular software program. The first section, a primer on terms and fundamentals, will prepare the reader for the hands-on exercises in Part Two.

Part Three defines and lists additional *WordStar* menus and functions. A practice diskette, troubleshooting guide, and glossary are also included.

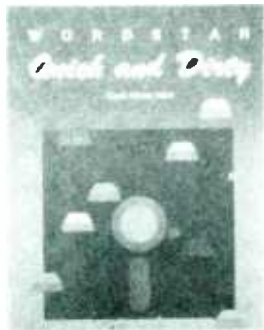

CIRCLE 91 ON FREE INFORMATION CARD

WordStar Quick and Dirty contains complete descriptions and command explanations for the Main, Help, Quick, Print, and On-Screen Menus, function keys, and dot commands. There are sections on the basic DOS functions and on how to use Mail-Merge. Instructions, self-tests, and practice exercises help the reader learn to enter documents, move and delete text, set and change tabs and margins, center text, and create business letters, outlines, and special effects.

WordStar Quick and Dirty has 162 pages and sells for \$13.95 from National Publishers, 47 Nepperhan Avenue, Elmsford, NY 01523; Tel. 914-592-6006.

Advanced C, Second Edition By Herbert Schildt

Experienced C programmers can become professional C programmers by reading *Advanced C, Second Edition*. This thoroughly revised book covers the new ANSI standard, as well as the Kernighan and Ritchie *de facto* standard, and contains many useful algorithms, functions, and approaches written in the C language. Any ANSI Standard compiler will compile and run virtually all the example codes presented in the book.



CIRCLE 93 ON FREE INFORMATION CARD

In *Advanced C*, readers will find information on sorting and searching; simulations; queues, stacks, linked lists, and binary trees; memory models; and dynamic allocation. The book also discusses interfacing to assembly-language routines and operating systems, efficiency, porting, and debugging. The complete code for a recursive-descent parser is included.

Advanced C, Second Edition has 403 pages, and is available for \$21.95 from Osborne McGraw-Hill, 2600 Tenth St., Berkeley, CA 94710.

More Advanced Power Supply Projects

By R.A. Penfold

This companion volume to *Power Supply Projects* should interest anyone with a reasonable knowledge of power-supply basics who would like to learn more about recent developments and advanced designs. In-depth knowledge of electronic-circuit design is not a prerequisite; the practical and theoretical aspects of the circuits are covered in some detail. However, it is recommended that anyone unfamiliar with the fundamentals of power-supply design and operation read *Power Supply Projects* first.



CIRCLE 97 ON FREE INFORMATION CARD

Some of the topics covered in *More Advanced Power Supply Projects*—including three terminal-adjustable voltage regulators—are simply recent developments, rather than advanced designs. Most of the subjects presented are of a more-advanced nature. Switched-mode power supplies, precision regulators, dual-tracking regulators, and computer-controlled supplies are among the subjects covered.

More Advanced Power Supplies (order No. BP192) as well as *Power Supply Projects* (order No. BP76) are avail-

able for \$7.95 each, including shipping, from Electronics Technology Today, P.O. Box 240, Massapequa, NY 11762.

Using Microsoft Windows By Ron Person

Windows is Microsoft's new graphics-based operating environment that lets users run several programs at one time. Heralding a new generation of user-friendly software, Windows takes advantage of high-powered processors and high-resolution displays to produce a working environment that promises to make personal computers more productive.

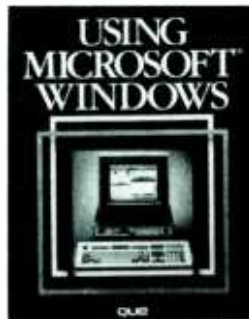

CIRCLE 94 ON FREE INFORMATION CARD

To help users learn the unique new Windows environment, Que Corporation is publishing *Using Microsoft Windows*, an informative guide to both Windows 2.0 and Windows/386. The book will benefit anyone beginning to use Windows or Windows applications, as well as users looking forward to the OS/2 Presentation Manager.

Using Microsoft Windows is written in an easy-to-understand style and incorporates numerous hands-on practice sessions to help the average user get up and running with Windows and Windows applications. Complete with numerous tips and notes, the book is divided into the following sections: getting started—demonstrates how to install Windows on a hard disk, as well as general operation of the Windows interface and the MS-DOS executive, using Windows—shows how to use Windows Write, Windows Paint, and Desktop Applications, advanced applications—discusses how to run standard DOS applications, integrate multiple applications, and use Windows/386.

Using Microsoft Windows, contains 450 pages, costs \$19.95. It's available from Que Corporation, 7999 Knue Rd., Suite 202, Indianapolis, IN 46250; Tel. 317/842-7162.

(Continued on page 102)

Put Professional Knowledge and a COLLEGE DEGREE in your Technical Career through HOME STUDY

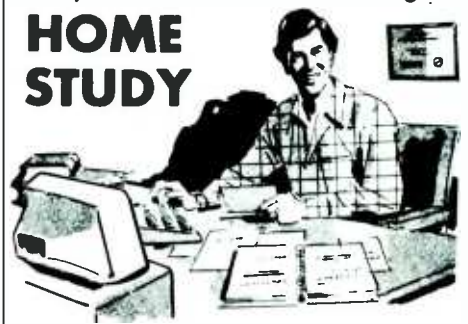

Add prestige and earning power to your technical career by earning your Associate or Bachelor degree through directed home study.

An important part of being prepared to *move up* is holding the right college degree, but the absolutely necessary part is *knowing your field*. Grantham can help you accomplish both objectives—to learn more *and* earn your degree, both of which together will prepare you for promotion in your present employment or for new better employment. Learn much more about

ELECTRONICS

and COMPUTERS,

as Grantham helps you *understand* your subjects and become a highly qualified expert, as you move thru the home study program and earn your accredited college degree.

No commuting to class. Study at your own pace, while continuing on your present job. Learn from easy-to-understand lessons, with help from your Grantham instructors when you need it.

Write for our free catalog (see address below) or telephone us at (213) 493-4421 (no collect calls) and ask for our "degree catalog."

Accredited by

the Accrediting Commission of the
National Home Study Council

GRANTHAM
College of Engineering
10570 Humbolt Street
Los Alamitos, CA 90720

Electronics Paperback Books

GREAT ELECTRONICS PAPERBACKS FROM ETT

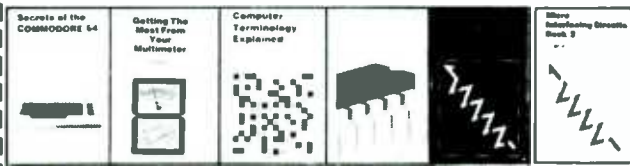

- BP195—INTRODUCTION TO SATELLITE TV.....\$8.00.** A definitive introduction to the subject written for the professional engineer, electronics enthusiast, or others who want to know more before they buy. 8 x 10 in.
- BP128—20 PROGRAMS FOR THE ZX SPECTRUM AND 16K ZX82.....\$5.75.** Included with each program is a flow chart and a description of what happens. Notes for converting programs for use on other computers are also included.
- BP235—POWER SELECTOR GUIDE.....\$10.00.** Complete guide to semiconductor power devices. More than 1000 power handling devices are included. They are tabulated in alpha-numeric sequence, by technical specs. Includes power diodes, Thyristors, Triacs, Power Transistors and FET's.
- BP234—TRANSISTOR SELECTOR GUIDE.....\$10.00.** Companion volume to BP235. Book covers more than 1400 JEDEC, JIS, and brand-specific devices. Also contains listing by case type, and electronic parameters. Includes Darlingtons transistors, high-voltage devices, high-current devices, high power devices.
- BP99—MINI-MATRIX BOARD PROJECTS.....\$5.00.** Here are 20 useful circuits that can be built on a mini-matrix board that is just 24 holes by ten copper-foil strips.
- BP157—HOW TO WRITE ZX SPECTRUM AND SPECTRUM GAMES PROGRAMS.....\$5.95.** A crystal-clear step-by-step guide to writing your own graphics games programs.
- BP117—PRACTICAL ELECTRONIC BUILDING BLOCKS—Book 1.....\$5.75.** Oscillators, Timers, Noise Generators, Rectifiers, Comparators, Triggers and more.
- BP184—INTRO TO 68000 ASSEMBLY LANGUAGE.....\$6.50.** The 68000 is a great new breed of microprocessor. Programming in assembly language increases the running speed of your programs. Here's what you need to know.
- BP179—ELECTRONIC CIRCUITS FOR THE COMPUTER CONTROL OF ROBOTS \$5.00.** Data and circuits for interfacing the computer to the robot's motors and sensors.
- BP126—BASIC & PASCAL IN PARALLEL.....\$4.95.** Takes these two programming languages and develops programs in both languages simultaneously.
- BP198—AN INTRODUCTION TO ANTENNA THEORY...\$6.95** Basic concepts relevant to receiving and transmitting antennas.
- 225—A PRACTICAL INTRODUCTION TO DIGITAL IC'S.....\$4.95.** Mainly concerned with TTL devices. Includes several simple projects plus a logic circuit test set and a digital counter timer.
- BP170—INTRODUCTION TO COMPUTER PERIPHERALS.....\$5.95.** Shows how to use a variety of co computer add-ons in as non-technical a way as possible.
- 227—BEGINNERS GUIDE TO BUILDING ELECTRONIC PROJECTS.....\$5.00.** How to tackle the practical side of electronics so you can successfully build electronic projects.
- BP169—HOW TO GET YOUR COMPUTER PROGRAMS RUNNING.....\$5.95.** Shows how to identify error in program and what to do about them.
- BP194—MODERN OPTO DEVICE PROJECTS.....\$6.25.** Crammed with great projects for the experimenter. Includes sections on Fiber optics, passive Infra-Red detectors, plus an assortment of miscellaneous projects..
- BP180—ELECTRONIC CIRCUITS FOR THE COMPUTER CONTROL OF MODEL RAILROADS.....\$6.25.** It's easy to interface home computers to model railroad control. The main problem is in interfacing the computer to the system.
- BP110—HOW TO GET YOUR ELECTRONIC PROJECTS WORKING.....\$5.00.** How to find and solve the common problems that can occur when building projects.

- BP239—GETTING THE MOST FROM YOUR MULTIMETER..... \$5.75.** Covers basics of analog and digital meters. Methods of component testing includes transistors, thyristors, resistors, capacitors and other active and passive devices.
- BP36—50 CIRCUITS USING GERMANIUM, SILICON & ZENER DIODES.....\$5.00.** A collection of useful circuits you'll want in your library
- BP37—50 PROJECTS USING RELAYS, SCR'S & TRIACS.....\$5.00.** Build priority indicators, light modulators, warning devices, light dimmers and more.
- BP39—50 FET TRANSISTOR PROJECTS.....\$5.50.** RF amplifiers, test equipment, tuners, receivers, tone controls, etc.
- BP42—SIMPLE LED CIRCUITS.....\$5.00.** A large selection of simple applications for this simple electronic component
- BP127—HOW TO DESIGN ELECTRONIC PROJECTS.....\$5.75.** Helps the reader to put projects together from standard circuit blocks with a minimum of trial and error.
- BP122—AUDIO AMPLIFIER CONSTRUCTION.....\$5.75.** Construction details for preamps and power amplifiers up through a 100-watt DC-coupled FEO amplifier
- BP92—CRYSTAL SET CONSTRUCTION.....\$5.00.** Everything you need to know about building crystal radio receivers.
- BP45—PROJECTS IN OPTOELECTRONICS.....\$5.00.** Includes infra-red detectors, transmitters, modulated light transmission and photographic applications
- BP48—ELECTRONIC PROJECTS FOR BEGINNERS.....\$5.00.** A wide range of easily completed projects for the beginner. Includes some no-soldering projects.
- BP49—POPULAR ELECTRONIC PROJECTS.....\$5.50.** Radio, audio, household and test equipment projects are all included.
- BP51—ELECTRONIC MUSIC AND CREATIVE TAPE RECORDING.....\$5.50.** Shows how you can make electronic music at home with the simplest and most inexpensive equipment.
- BP56—ELECTRONIC SECURITY DEVICES.....\$5.00.** Includes both simple and more sophisticated burglar alarm circuits using light, infra-red, and ultrasonics.
- BP59—SECOND BOOK OF CMOS IC PROJECTS.....\$5.00.** More circuits showing CMOS applications. Most are of a fairly simple design.
- BP72—A MICROPROCESSOR PRIMER.....\$5.00.** We start by designing a small computer and show how we can overcome its shortcomings
- BP74—ELECTRONIC MUSIC PROJECTS.....\$5.95.** Provides the experimenter with a variety of practical circuits including a Fuzz Box, Sustain Unit, Reverberation Unit, Tremolo Generator and more.
- BP91—AN INTRODUCTION TO RADIO DXING.....\$5.00.** How you can tune in on those amateur and commercial broadcasts from around the world in the comfort of your home.
- BP94—ELECTRONIC PROJECTS FOR CARS AND BOATS.....\$5.00.** Fifteen simple projects that you can use with your car or boat. All are designed to operate from 12-volt DC supplies.

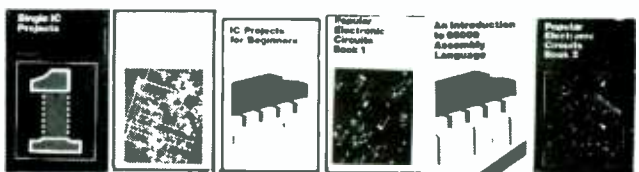

ELECTRONIC TECHNOLOGY TODAY INC.
P.O. Box 240, Massapequa Park, NY 11762-0240

Name _____
Address _____
City _____ State _____ Zip _____

SHIPPING CHARGES IN USA AND CANADA

\$0.01 to \$5.00	... \$1.25
\$5.01 to 10.00	... \$2.00
\$10.01 to 20.00	... \$3.00
\$20.01 to 30.00	... \$4.00
\$30.01 to 40.00	... \$5.00
\$40.01 to 50.00	... \$6.00
\$50.01 and above	... \$7.50

SORRY No orders accepted outside of USA & Canada

Number of books ordered

Total price of merchandise \$ _____
Sales Tax (New York State Residents only) \$ _____
Shipping (see chart) \$ _____

All payments must be in U.S. funds

Total Enclosed .. \$ _____

H9-88



SQUIRT GUNS THAT SCORE

Traditional summer fun
enters the electronics age!

By Tom Fox

SUMMER JUST WOULDN'T BE SUMMER WITHOUT SWIMMING, baseball, fresh corn-on-the-cob, outdoor cookouts, and, of course, a good squirt-gun fight. While sophisticated, motorized water guns are now available, the traditional simple and inexpensive ones are nearly as much fun. Generally, in competitive water-gun warfare, the one who is able to avoid that dripping-wet, soaked look for the longest period of time is the victor. Obviously, such a victory is subjective and generally everyone claims to be the champion.

Being a frequent participant in water-gun fights (the author has four boys!), we decided to design an electronic water-gun game. In this game, which the author calls *Squirt-Gun Tag*, a vest (with small targets attached front and back close to the heart area) is worn. When the target is hit by a stream of water from a squirt gun, a buzzer sounds for about four seconds.

The buzzer signals a direct hit, which eliminates that old phony retort: "No, you dummy, you missed me!" Buzzers don't lie. By watching the broad smiles and obvious excitement on their faces as they play, children obviously think the new game is fantastic. While *Squirt-Gun Tag* may not totally replace a typical water-gun battle, where everyone always ends up soaking wet, it does add variety to water-gun warfare.

A Little Squirt

Figure 1 shows the schematic diagram of *Squirt Gun Tag*. Two sensors, SS1 and SS2, are connected to U1, an LM1830 fluid detector, which passes an AC signal across the sensor. The sensors are nothing more than small PC boards with conductive parallel strips. When the targets are dry, the contacts between pin 10 of U1 and ground are not bridged; therefore, the output of U1 at pin 12 is low. That low is applied along two main paths: In the first path, the low output of U1 is inverted by U2-a, with the resulting high fed to pin 2 (trigger) of U3. Because the 555 is activated by a negative trigger, U3 does not oscillate and no sound is produced.

Along the other path, the initial low output of U1 is fed through U2-b, where it is inverted (providing a high), and again divides to follow two paths. In the first of those paths, the inverted output of U2-b is input to one-leg of the U4-c/U4-d combination, enabling both gates. At the same time, the inverted output of U2-b (a high) is inverted by U2-c, applying a low to one leg of the U4-a/U4-b parallel combination—effectively, disabling that pair of gates.

Both sets of parallel connected NAND gates, U4-a/U4-b and U4-c/U4-d, have one input tied to an oscillator consisting of U2-d and U2-e. When the oscillator output swings between positive and negative, the output of the U4-c/U4-d combo first goes low, and then high. (Recall that the other input is held high by the output of U2-b.) That alternating signal causes LED1 to flash in time with the oscillator output. At the same time, the low applied to the U4-a/U4-b combo prevents their output from alternating between high and low, so LED2 remains dark.

But when water hits a target, pin 12 of U1 goes high. That high is fed to pin 1 of U2-a, as previously described, forcing its output low. Integrated circuit U3, which is tied to the output of U2-a via C4, begins to oscillate, causing BZ1 to sound. At the same time, that high is fed to pin 3 of U2-b, forcing its output low. That low is applied to the U4-c/U4-d combo, producing a high output, which causes LED1 to go dark. The output of U2-b is inverted by U2-c, and fed to the input of the U4-a/U4-b combo, enabling those gates. Now as the oscillator output alternates between high and low, LED2 flashes in time with the oscillator.

The combination of D1, C3, and R2-R4, in conjunction with U2-a, eliminates jitter as the sensor dries. Diode D2 limits the positive pulse (which occurs at sensor dry off) to a one-diode voltage drop. Resistor R5 is used to maintain a normally positive voltage at pin 2 of U3, while capacitor C6 and resistor R6 set the on time for the buzzer, BZ1, at about 4 seconds.

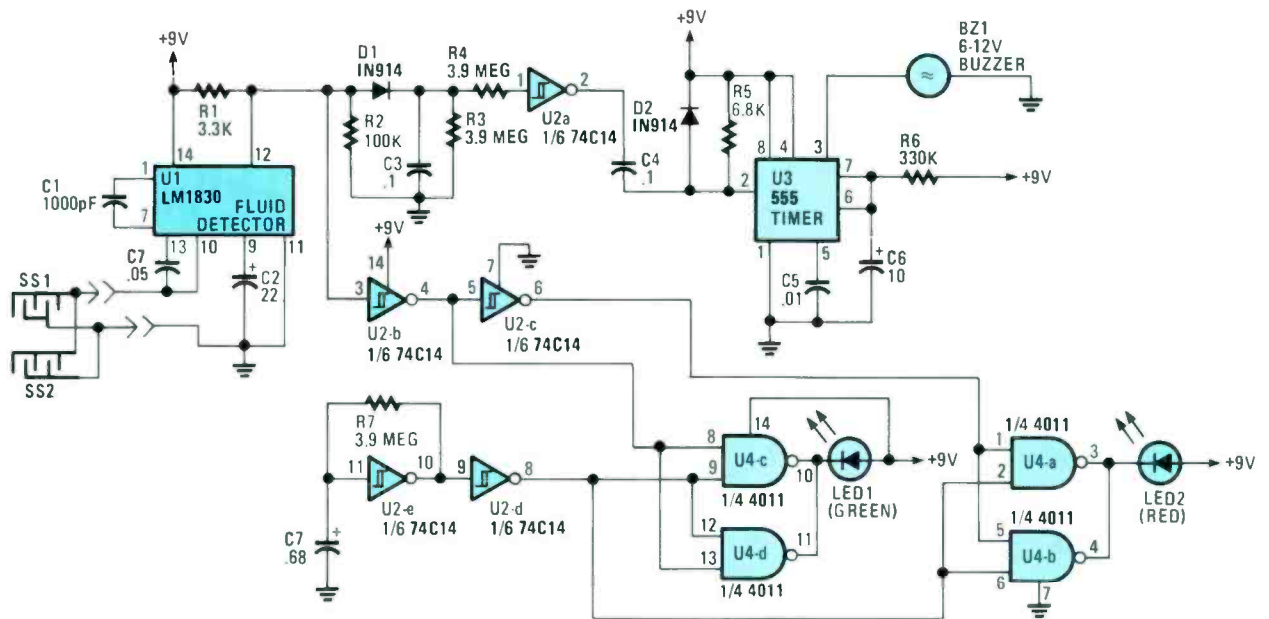

Fig. 1—The schematic diagram of Squirt-Gun Tag. SS1 and SS2 are connected parallel to U1 (an LM1830 fluid detector), which is used to control the rest of the circuit.

Construction

While the circuit is simple enough to be built using any construction method, a printed-circuit board is recommended for compactness and increased reliability. Since the unit may be attached to energetic children, reliability is a prime concern. Figure 2 shows the foil pattern for the Squirt Gun Tag's printed-circuit board. Recall that the targets (SS1 and SS2, a few patterns for which are presented later) are also

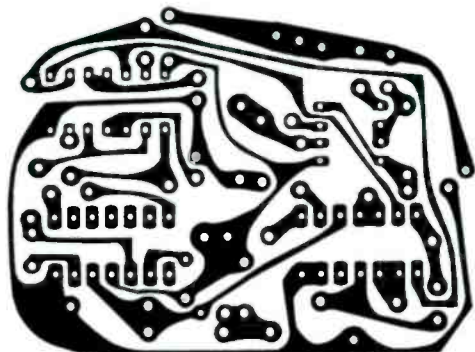

Fig. 2—While the circuit is simple enough to be built using any construction method, a PC board is recommended for compactness and increased reliability.

printed circuits. Once the circuit board is etched and all the parts (see Parts List) have been obtained, construction can begin. Populate the circuit board using Fig. 3, the parts-placement diagram, as a guide. Buzzer BZ1 and switch S1 are mounted on the case. SS1 and SS2 are the targets and are attached to the vest.

To increase battery life, the LED's can be driven by single NAND gates rather than parallel NAND gates as indicated; of course, if that is done the LED's won't be as bright. For single NAND gate drive, use a knife or fine file to sever the appropriate foils. Also connect pins 12 and 13 of U4 to pin 14 and pins 5 and 6 to pin 7.

The unit can be housed in a Radio Shack experimenter's box (RS No. 270-221), which measures $4 \times 2\frac{7}{16} \times 1\frac{1}{16}$

PARTS LIST FOR SQUIRT-GUN TAG

SEMICONDUCTORS

- U1—LM1830 fluid detector, integrated circuit
- U2—74C14 CMOS hex, integrated circuit Schmitt-trigger inverter
- U3—555 oscillator/timer, integrated circuit
- U4—CD4011BE CMOS quad 2-input NAND-gate, integrated circuit
- D1, D2—1N914 (or equivalent) small-signal silicon diode
- LED1—High-brightness green light-emitting diode
- LED2—High-brightness red light-emitting diode

RESISTORS

- (All resistors are 1/4-watt, 5% units, unless otherwise noted.)
- R1—3300-ohm
 - R2—100,000-ohm
 - R3, R4, R7—3.9-megohm
 - R5—6800-ohm
 - R6—330,000-ohm

CAPACITORS

- C1—1000-pF ceramic disc
- C2—22- μ F, 25-WVDC subminiature electrolytic
- C3, C4—0.1- μ F, ceramic disc
- C5—0.01- μ F, ceramic disc
- C6—10- μ F, 25-WVDC subminiature electrolytic
- C7—0.68- μ F, 35-WVDC subminiature tantalum

ADDITIONAL PARTS AND MATERIALS

- BZ1—6-to-9 volt buzzer
- PL1—RCA-type phono plug
- S1—Single-pole, double-throw switch
- SS1, SS2—custom-made targets (see text)
- Printed circuit or perfboard materials, enclosure, IC sockets, 9-volt transistor-radio battery, battery holder, battery clip, key-ring clip (see text), two-conductor cable, vinyl material (used on vest), Velcro sticky-back tape, decorative stickers, acrylic spray, solder, hardware, etc.

Note: The LM1830 is available from Digi-Key Corporation, 701 Brooks Ave. South, PO Box 677, Thief River Falls, MN 56701-0677; Tel. 800/344-4539.

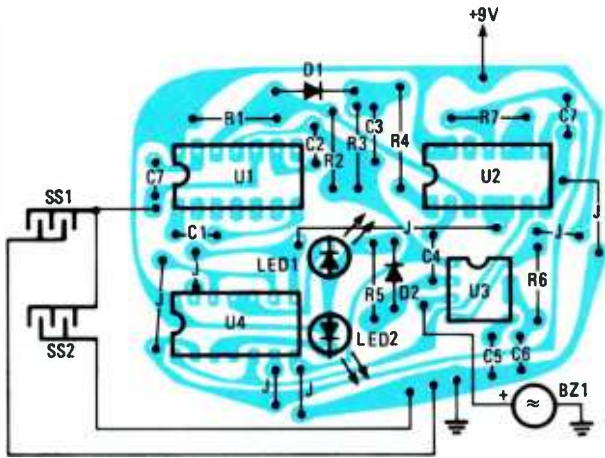

Fig. 3—Populate the circuit board using this parts-placement diagram as a guide. Note that BZ1 and S1 are mounted on the case, and that SS1 and SS2 are the targets, which are attached to the vest.

inches. All parts easily fit into that case, but it's still quite compact. Adhesive-backed stickers are used to decorate the units. The stickers the author used are relatively inexpensive, and come in a large variety of designs. Make sure that you protect the stickers from water by spraying on a clear acrylic spray or brushing on a clear plastic-based sealant.

There are several ways of attaching the Squirt-Gun Tag unit to the user. Simply sticking the unit in one's pocket is not suitable, because the LED's would not be visible and the buzzer's sound level would be drastically reduced. The author decided to put a clip on the back of the unit so that it could be worn on one's belt, pants pocket, shirt pocket, etc. A common key-ring clip can be used. Two holes are drilled into the clip as shown in Fig. 4. The clip is attached to the back of the unit with two small machine screws.

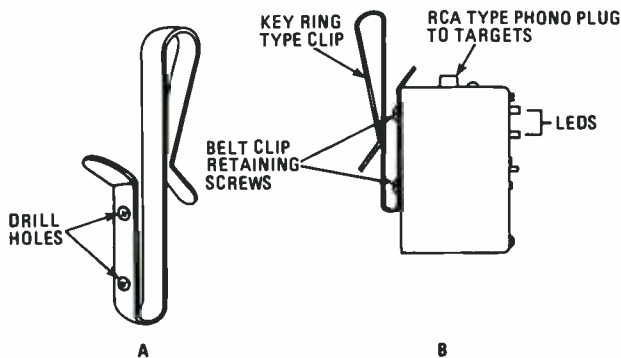

Fig. 4—There are several ways of attaching the Squirt-Gun Tag unit to the user, but simply pocketing the unit is not suitable. The author attached a belt clip to the back of the enclosure with two small machine screws.

On Target

The targets for the game are simple circuit boards with two closely-spaced parallel conductive strips. When water hits the area between the conductive strips, bridging the gap between the two, the buzzer sounds. As a note of interest, the author used as a foil pattern the first letter of one of his son's names for the foil pattern. For instance, his youngest son is Matthew so he used an "M" for Matthew's target.

Using personalized targets seems to increase the child's enjoyment of the game. Fig. 5 gives four different PC-foil

patterns for the target. The "burst" foil pattern in Fig. 5D requires jumpers on the non-foil side to connect the narrow foil strips. Use a fine wire such as #30 wire-wrap wire. The foil patterns in Fig. 5 are meant as demonstration patterns.

The author advises the reader to use his or her imagination when designing the target—just make sure there are two parallel conductive strips that are close together (less than a quarter inch). Keep in mind that the closer together the strips, the more sensitive the target. When it comes time to make the actual circuit boards for the targets, use an etch resist pen (a permanent marker should also work), etch resist tape, direct-etch dry transfers, or rub-down copper strips for such a simple pattern.

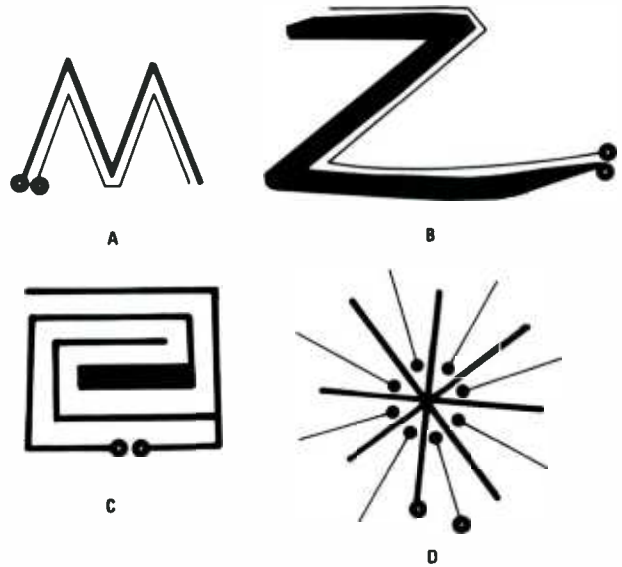
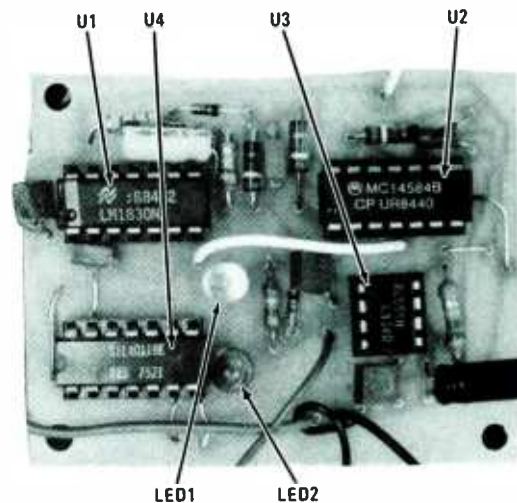

Fig. 5—Customizing the targets seems to increase the child's enjoyment of the game. Shown here are four different printed-circuit foil patterns for the targets. The foil pattern in "D" requires jumpers on the non-foil side off the board to connect the narrow foil strips.



Squirt-Gun Tag's fully-populated printed-circuit board is shown here prior to being permanently sealed in its compact plastic enclosure. While you need not use so small an enclosure, its size does allow greater freedom of movement.

The vest, whose primary function is to hold the targets, can be made from vinyl material (such as that used for tablecloths), which is available from craft stores. The size of the

(Continued on page 98)

THE AUDIO CRYSTAL FILTER

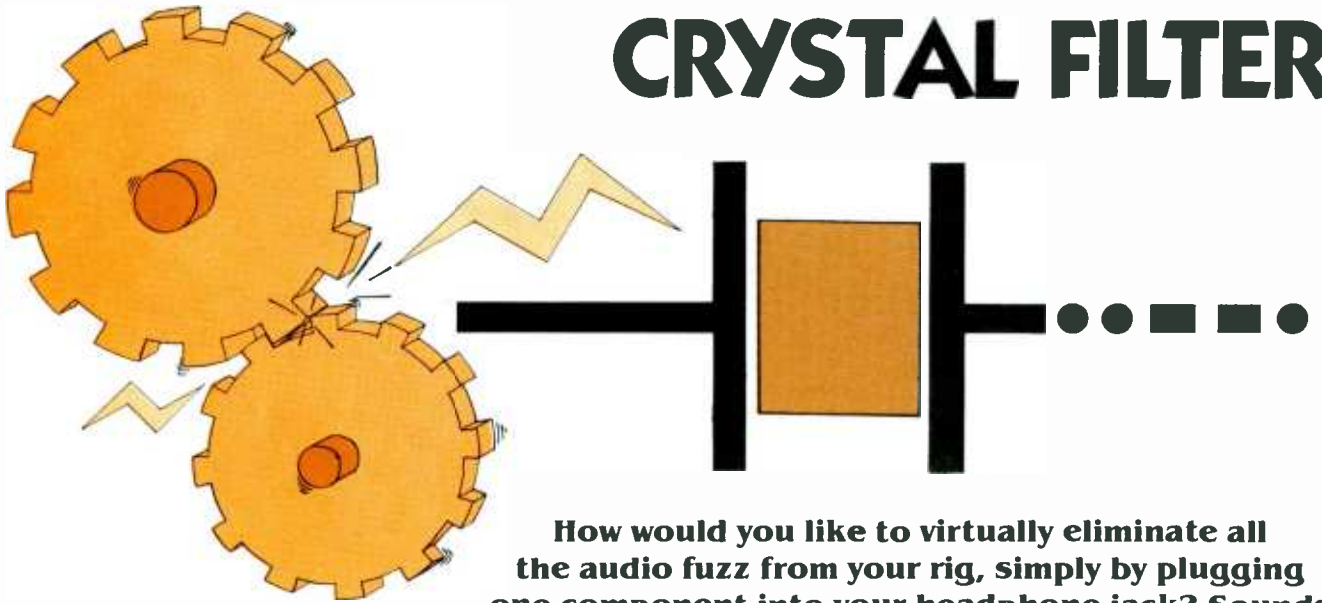

How would you like to virtually eliminate all the audio fuzz from your rig, simply by plugging one component into your headphone jack? Sounds too good to be true? Read on and rejoice!

By Larry Lisle, K9KZT

WOULD YOU LIKE RAZOR-SHARP SELECTIVITY FOR Morse-Code reception? Would you like it even better if it cost less than two dollars, and could be had for five minutes of work modifying your receiver? If the answer is yes, the *Audio Crystal Filter* may be for you!

Some History

Separating the stations you want to hear from those you don't has been a receiver problem for a long, long time.

A giant step forward was the introduction of the high-frequency crystal filter in the early 1930's. It was a quartz crystal placed in the IF signal path of a superheterodyne receiver. The crystal filter gave unprecedented selectivity. A signal at the series resonant frequency of the crystal would be passed with little attenuation, while undesired signals, only a few hundred hertz away, could scarcely be heard. The development of the crystal filter was one of the main reasons for the increase in popularity of the superheterodyne receiver among radio amateurs, who had previously used the simpler regenerative receiver.

Eureka!

Recently I was thinking about building an audio filter for code reception, when I passed a display of piezo transducers in an electronic-parts store. The devices change an electrical signal into sound and are widely used in smoke detectors and other alarms.

The idea struck me that maybe they could be used for the audio equivalent of a crystal filter. After a little fiddling, I discovered that I could simply use one as a speaker!

They really work great! As you can see from Fig. 1, the bandwidth at 3-dB down is less than 200 Hz and at 6-dB down the bandwidth is still less than 400 Hz. That is what you call a *sharp* filter!

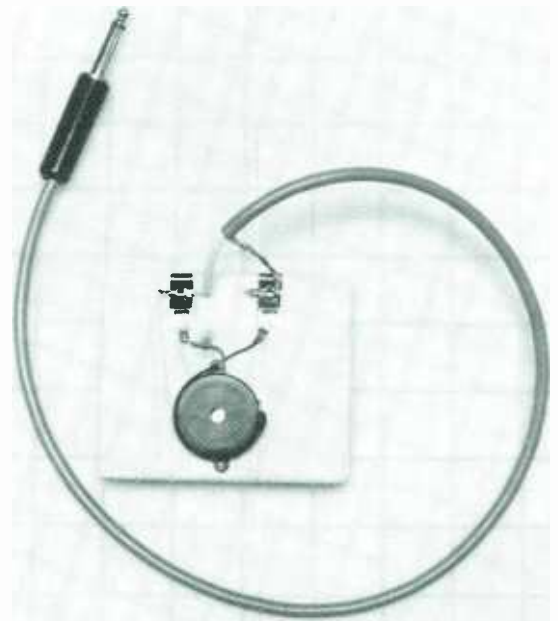

The Audio Crystal Filter is a piezo transducer resonant at about 2300 Hz. It's used as a sharply resonant speaker and is simply plugged into the headphone jack of a receiver or transceiver. Despite its simplicity its 6-dB down bandwidth is less than 400 Hz. This is a sharp filter!

Use and Restrictions

The results in practical use are very good. One of these devices will really improve an older receiver of the wide-open variety, or even a more modern receiver or transceiver with a filter designed for voice work.

(Continued on page 96)

**Set up your work area in seconds,
and clean up even faster!**

By Leo Simpson



PORTABLE ELECTRONICS WORKBENCH

Do you build your electronic projects on the kitchen table like I do? If the answer is yes, then you detest the hassle of clearing it all away at the end of the work session and then getting it all out again the next time.

Let's face it, most of us don't have a special room or workbench where we can pursue our hobby of electronics. Most of us make do with the kitchen table for our electronics assembly and design work. Afterwards, we have the problem of clearing it all away for distractions, like meals.

Having had to put up with that problem for many years, I decided to look for a way to solve it. What was needed was some sort of portable workbench arrangement that could accommodate all the electronics paraphernalia of the moment, but could be packed away at a moment's notice beneath the bed, on top of the wardrobe, or even behind a door.

Even if you have a workshop or a workbench in your garage, there are times when you want to work in the kitchen or family room. This past winter was a cold one for working in an unheated garage. Maybe you want to be with your family while you work on your hobby, or maybe there's a TV show you don't want to miss while you work. And you have to admit that in the kitchen you are close to the coffee pot and snacks. In other words, there are many good reasons for having a portable workbench that can be set up quickly and with a minimum of fuss.

Based on an article appearing in *Silicon Chip*, November 1987 issue. Reprinted here by permission.

One Man Think Tank

I evolved the design of the workbench over a period of several weeks, but I am sure that readers will be able to come up with their own refinements. I wanted plenty of space to spread parts around, a power supply, soldering iron, reels of hookup wire, and so on. The workbench also had to have a set of parts drawers and provision for tool storage.

The idea is that when you finish working on a project for the moment, you can push all the paraphernalia towards the back of the workbench and then put the whole box away. If necessary, you might want to upend it so that it can sit behind a door. It could also be hung up on a wall out of the way.

The Portable Electronics Workbench I designed is a flat work surface that's 32-inches wide by 25-inches deep with sloping sides, a closed back, and a narrow shelf along the back. Complete dimensions are given in Fig. 1.

Naturally, the dimensions can be varied to suit what you have on hand, but the workbench shouldn't be made much smaller or the work area will be too cramped. By the same token, it should not be made much larger either, otherwise it will be too heavy and unwieldy to carry.

To make my own Portable Electronics Workbench, I used finished-surface particle-board, which gives a durable and easily cleaned work surface. You will find a wood-veneer surface on particle-board to be very good. The sheet I used was $5/8$ -inch thick, but, in hindsight, $1/2$ -inch material would have been strong enough and much lighter to carry.

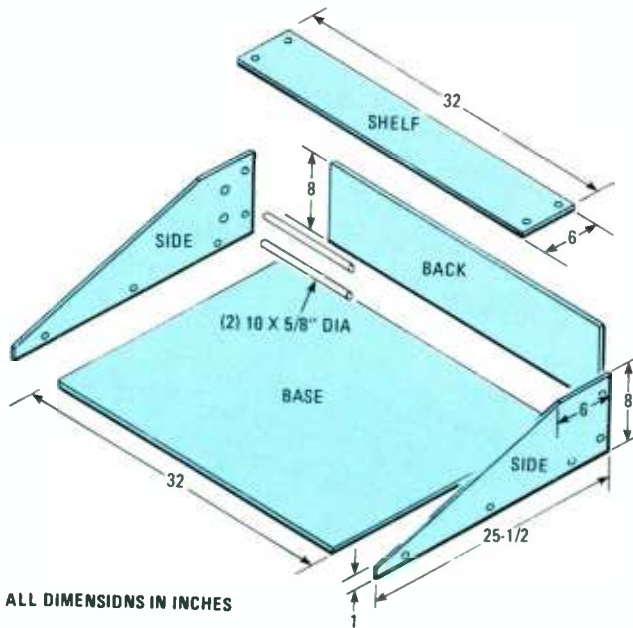

ALL DIMENSIONS IN INCHES

Fig. 1—The diagram shows how the pieces of the Portable Electronics Workbench fit together and gives the dimensions in inches. The overall length of the back piece depends on the width of the wood used. This length can be cut to fit from a rough cut of 32 inches. You may vary the dimensions, but don't make the work area much smaller than that shown.

For a few bucks more you can use plywood that's smooth on both sides; the side pieces could be solid pine.

Don't use bare particle-board. It might be cheap, but it's unpleasant to work upon, the surface is easily abraded, and it absorbs any spilled liquids and swells up like a sponge. Even if you try to seal it with shellac or some other finish, it is rarely satisfactory. In short, forget it.

Of course, such a workbench (dare we call it a *work center* or even a *work station*?) need not be confined to electronic activities. It could be used equally well for other hobby work, such as model building.

Working with Wood

Don't let your lack of carpentry skills frighten you away from building the Portable Electronics Workbench. As long as you have a circular saw and an electric drill, you can build this project with ease. If you have to pump an old hand saw, see if you can borrow a circular saw or get some neighbor to pre-cut the pieces on his table saw before you begin assembly. Unless they have silicon-carbide teeth, hand-saw blades are quickly dulled by cutting particle board.

PARTS LIST— PORTABLE ELECTRONICS WORKBENCH

- 1—sheet of 1/2- or 5/8-in. particle board or plywood (refer to text for overall size)
- 1—Power strip, 4, 3-prong AC outlets with master power switch
- 18—2-in. #8-gauge flathead-wood, chipboard, or sheet-metal screws
- 8—75-foot reels of hookup wire (select different color insulation and stranded and solid copper wire)
- 2—12-in. dia., 5/8-in. dowels (for reels of hookup wire)
- 4—Rubber feet
- Adhesive (to glue dowels in place), paint materials (optional).

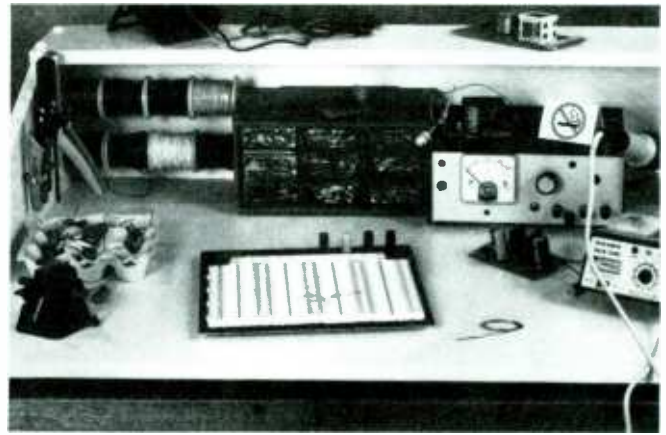

Ready for work, the Portable Electronics Workbench also includes a soldering station (notice the power strip secured to the right side of the workbench). The nifty little suction-bottom bench vise is an invaluable extra. The reels of hookup wire are free to roll on two 5/8-inch diameter wood dowels. Notice the tools held by spring holders on the left side. Getting ideas? Then do your thing!

The assembly process consists of cutting the material to size, drilling the holes for the screws, and then simply screwing it together. No gluing is required, but don't let that stop you if you enjoy over-building a bit.

You need to start with a sheet of particle-board or plywood 1/2-inch thick, which will probably have a minimum size of 48 x 36-inches, depending on where you buy it. Some lumber yards and hardware outlets will cut the material to size for you for an extra charge. Hand the cutter a paper with the sizes jotted down clearly. Then, if he makes a cutting-size mistake, it's on him.

To ensure that you achieve straight cuts, use a straight edge as a guide for the power saw. The idea is to clamp a thin straight-edged length of timber to the particle-board or plywood, and use it as a guide for the saw.

Smooth off the saw surface with a rasp or sanding block before proceeding to the next step, which is to make the various right-angle butt joints to assemble the work bench.

The various sections are then screwed together. You can either use long #8 wood or chipboard screws (#8 self-tapping sheet-metal screws), which have coarse threads for easy penetration and good holding power. I used 2-inch #8, bright, zinc-plated, flathead wood screws.

Assuming the use of #8 wood screws, each screw position will need to have a 1/8-inch hole drilled for the threaded portion and then drilled out to 3/16-inch to take the shank of the screw. Don't drill too deep with the latter size, otherwise the screw will have no holding power. There is no unthreaded shank on a sheet-metal screw.

I used 18 screws to assemble my workbench, and that should be ample. When working with wood, amateur builders tend to over-build.

The Finishing Touches

It's a good idea to consider how you want to finish the workbench before you start. I wanted a white finish so I primed the exposed surfaces by sponging on a very thin coating of one part shellac and three parts wood alcohol. Be careful not to prime the areas where glue will be used, if any. Now paint the surfaces and exposed wood edges. One coat will do. A final coat of paint will be given to the

(Continued on page 102)

RAPID FIRE

If alien invaders constantly blast your armada out of existence because you're unable to fire a missile barrage, it's time to upgrade your space blaster.

By Jerry Penner

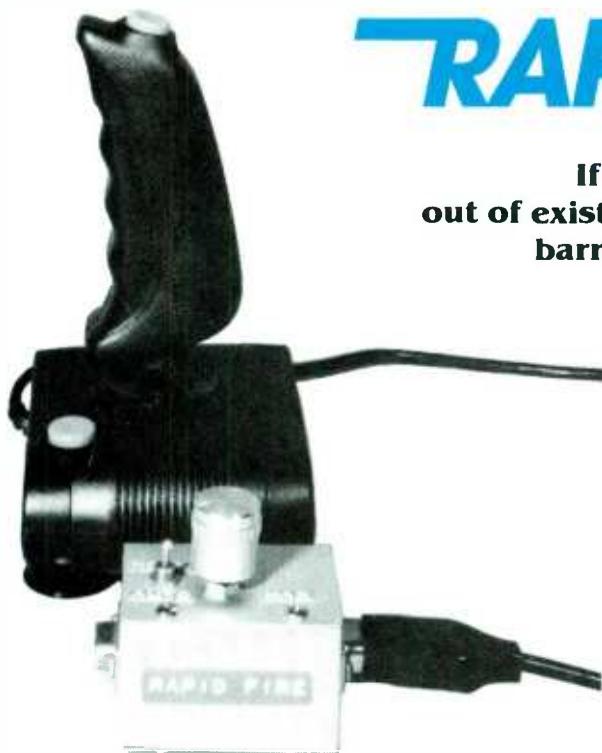

BOTH ON THE MARKET AND IN THE PUBLIC DOMAIN, there are many games that allow only one shot for each push of the joystick fire button. Examples of such games include *Moon Shuttle*, *Fort Apocalypse*, *Zaxxon*, *Asteroids*, and the timeless classic *Space Invaders*. Constant and relentless hammering on the button may cause loss in concentration and wear-and-tear on the fire button—while serving up a side order of sore fingers.

Fear not, fellow electronics *gamesters*; for the *RapidFire* circuit can convert your old, reliable, single-shot joystick to an automatic space-critter zapper!

The *RapidFire* circuit is compatible with all digital joysticks. It has an adjustable fire rate of about 3- to 15-shots per second, with a switch that sets the joystick back to single shot when needed. Since the circuit uses a CMOS 555, current drain is low (about 4 milliamps), so the host game unit doesn't even have to breathe hard to supply current. The unit is not only versatile, but cheap. The connectors cost more than the rest of the parts, box included.

If you have a joystick with enough room, you can cut needless expense by stashing the circuit inside the joystick housing. One thing you should check before hacking up a perfectly good joystick, though: Look for a wire running into the joystick from pin 7 of the DB-9 connector. If your joystick doesn't have a built-in paddle, it most likely has nothing connected to pin 7. That problem can be corrected by installing a new connector and cable with the proper number of wires.

How Joysticks Work

Figure 1 is a schematic representation of a digital joystick in its simplest form. Five normally-open, momentary, push-button switches, which share a common ground, select the four directions and initiate fire. To move up, S1 is depressed, connecting pin 1 of the DB-9 connector to ground (through pin 8). Similarly, to fire, switch S5 is depressed, grounding pin 6 on the DB-9 connector. To auto-fire, a method of grounding and releasing pin 6 must be developed.

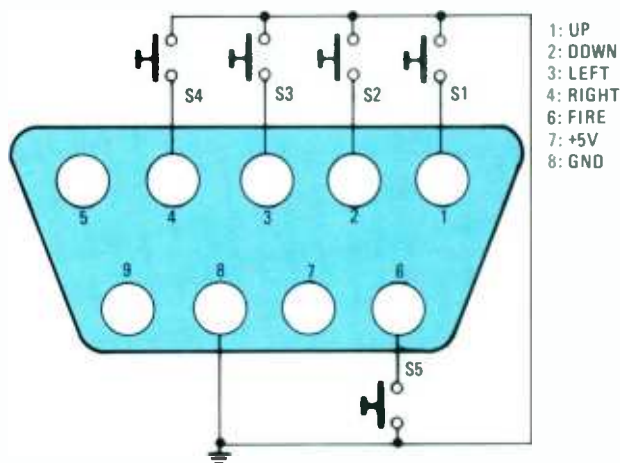

Fig. 1—Shown here is a schematic representation of a digital joystick in its simplest form. Five normally-open pushbutton switches (which share a common ground) are tied to a DB-9 connector, and used to select the four directions of movement and initiate the fire sequence.

The Circuit

Figure 2 shows a schematic diagram of the *RapidFire* circuit. The heart of the circuit is a 555 oscillator/timer set up as an astable multivibrator, whose timing is determined by components C1, R1, R2, and R3. Resistor R2 keeps the duty cycle at around 50%, while R3 adds adjustability to the firing rate. The resistance of R3 is not critical, but any value greater than 10,000-ohms produces a uselessly slow fire rate. Diode D1 acts like a single-input OR gate, and provides a high-impedance output.

At power-up, a positive voltage is fed to U1 pin 8 (providing power for the circuit). At the same time, that positive voltage is applied to pin 7 (discharge) through R1, to pin 6 (threshold) through the series combination of R2/R3. But because there is no ground-return path connected to the circuit and the fire button has not been depressed (at this point), the circuit is dormant.

Switch S1 changes the purpose of the joystick fire button itself. In the *RapidFire* position, the game-player ground line (pin 8 of J1) is swapped through the fire button and into the 555 timer, while fire (pin 6) is connected to the switching output at pin 3 of U1 via D1. With S1 (Fig. 2) in the Normal position, the game-player ground passes through the fire button and back to the fire input. Therefore, pressing S5, the fire control (in Fig. 1), has no effect on the *RapidFire* circuit, and single-fire operation is in effect.

But when S1 is placed in the auto position, a low is placed on pin 1 of U1, completing the power-supply circuit. That same low is sensed (through C1) at pin 2 (trigger), causing the

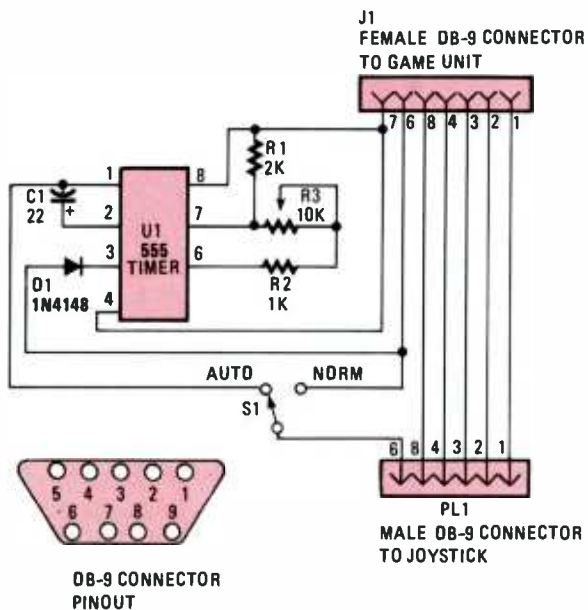
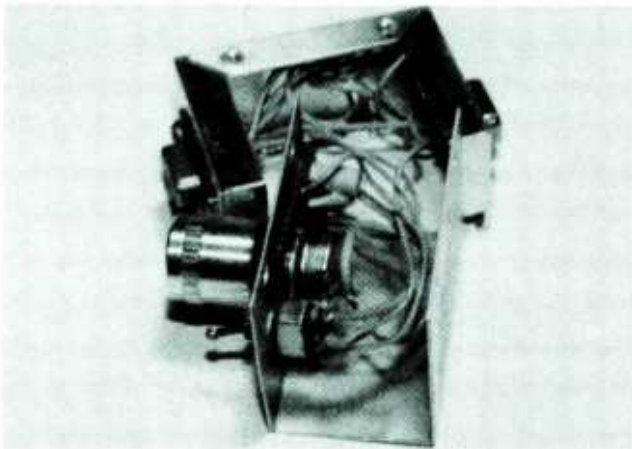

Fig. 2—This schematic diagram shows that at the heart of the RapidFire circuit is a CMOS 555 oscillator/timer set up as an astable multivibrator activated by the user.

circuit to oscillate—outputting a stream of pulses at pin 3 of U1. As the circuit oscillates, each negative-going transition of the output of U1 pulls pin 6 of J1 low. The game interprets each negative pulse as a fire command. At the end of the fire sequence, pin 6 is pulled high.

If diode D1 is inserted backwards, it will act as a voltage drop and pin 6 will not reach the necessary voltage level (about 5-V). In that event, the confused game unit may interpret what should have been multiple-firings as a single push of the fire button.



Shown here is the RapidFire circuit mounted on a small piece of perfboard just prior to sealing its enclosure. Note that the shaft of R3 and its mounting hardware hold the board in place.

Construction

While the RapidFire circuit can be put together using the construction method with which you are most comfortable, it is suggested that perfboard or printed-circuit board be used to keep everything compact. The circuit is simple enough that an IC socket should not be necessary. The foil pattern for the circuit is shown in Fig. 3. You may either use that foil pattern to make your printed circuit, or devise your own layout on printed-circuit or perfboard material. The choice is yours.

PARTS LIST FOR THE AUTOFIRE CIRCUIT

- U1—555 oscillator/timer, integrated circuit
- D1—1N4148 (or similar) small-signal, silicon diode
- C1—22- μ F, 6-WVDC, electrolytic capacitor
- R1—2000-ohm, 1/4-watt, 5% resistor
- R2—1-ohm, 1/4-watt, 5% resistor
- R3—10,000-ohm, linear-taper potentiometer
- J1—Female DB-9 connector
- PL1—Male DB-9 connector
- S1—Single-pole, single-throw, miniature toggle switch

ADDITIONAL PARTS AND MATERIALS

Printed-circuit or perfboard materials, enclosure, IC socket (optional), wire, solder, hardware, etc.

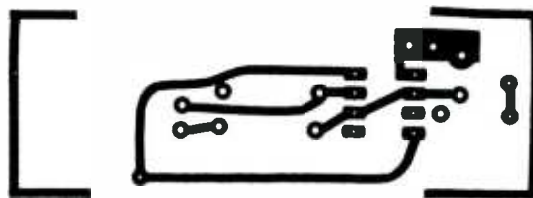

Fig. 3—The foil pattern for the RapidFire circuit (shown here full-scale) can be used to make your own printed-circuit board for neat circuit layout.

Begin construction by first mounting the DB-9 connectors on opposite sides of the selected enclosure (a 9-pin female for J1 and a 9-pin male for PL1). The author's prototype was mounted in a small aluminum enclosure. Solder wires on the male and female DB-9 connectors between pins 1, 2, 3, 4, and 8 (which are feed throughs).

Take careful note of the numbering of the pins on the back of each connector. The numbers are small and, without a magnifying glass, mistakes are easily made. Double-check your wiring when finished. The last thing you need on power-up is to realize only too late that you've coupled the +5 volt line through the fire button and directly to ground.

Place and solder the board-mounted components, using Fig. 4 as a guide. Again, check your work, making sure that all components are properly oriented, or (if you are using

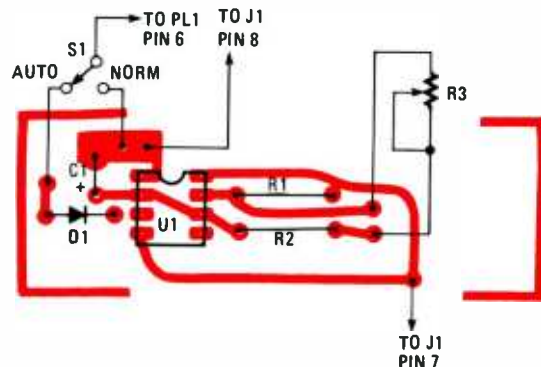

Fig. 4—Use this parts-placement diagram as a guide when populating RapidFire's printed-circuit board. Note: While several wire leads are shown connected between the two D-type connectors (pins 1, 2, 3, 4, 6, 7, 8) in the schematic diagram (Fig. 2), only the connections that must be detoured through the Auto Fire circuit are shown here.

perfboard) that the proper connections are made. Mount R3 so that the shaft of the potentiometer protrudes through the

(Continued on page 96)

82 Hands-on Electronics FactCard

4099 : 8-Bit Addressable Latch

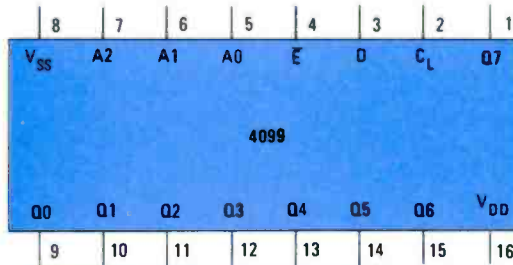

MODE SELECTION				
E	CL	ADDRESSED LATCH	UN-ADDRESSED LATCH	MODE
L	L	Follows Data	Holds Previous Data	Addressable Latch Memory
H	L	Holds Previous Data	Holds Previous Data	Memory
L	H	Follows Data	Reset to "0"	Demultiplexer Clear
H	H	Reset to "0"	Reset to "0"	Demultiplexer Clear

FEATURES

- Wide supply voltage range 3.0V to 15V
- High noise immunity 0.45V_{DD} (typ.) fan out of 2 driving 74L or 1 driving 74LS
- Low power TTL compatibility
- Serial to parallel capability
- Storage register capability
- Random (addressable) data entry
- Active high demultiplexing capability
- Common active high clear

ABSOLUTE MAXIMUM RATINGS

V _{DD} DC Supply Voltage	-0.5 to +18V _{DC}
V _{IN} Input Voltage	-0.5 to V _{DD} + 0.5V _{DC}
T _S Storage Temperature Range	-65° to +150°C
P _D Package Dissipation	500mW
T _L Lead Temperature (Soldering, 10 seconds)	260°C

RECOMMENDED OPERATING CONDITIONS

V _{DD} DC Supply Voltage	3.0 to 15V _{DC}
V _{IN} Input Voltage	0 to V _{DD} V _{DC}
T _A Operating Temperature Range	-55°C to +125°C
CD4099BM	-40°C to +85°C
CD4099BC	

83 Hands-on Electronics FactCard

MM53126 - Infrared Remote MM53226 - Control Transmitter

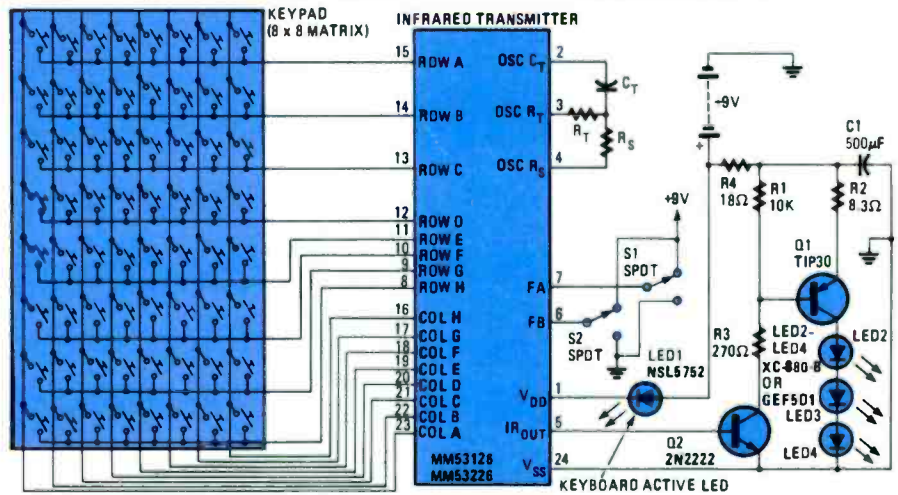

84 Hands-on Electronics FactCard

ICL7116 - 3½-Digit ICL7117 - A/D Converter

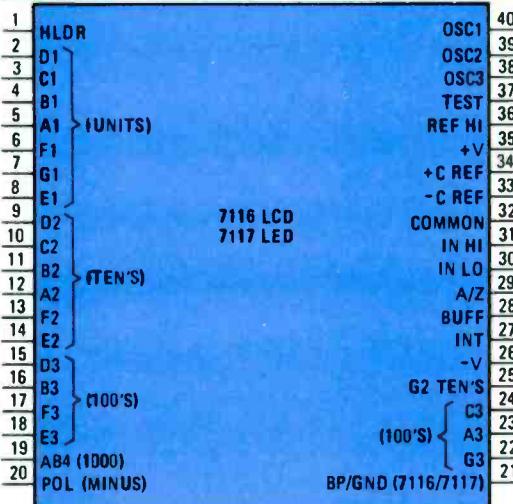

ABSOLUTE MAXIMUM RATINGS

ICL7116	
Supply Voltage (V ⁺ to V ⁻)	15V
Analog Input Voltage (either input) (Note 1)	V to V ⁻
Reference Input Voltage (either input)	V to V ⁺
HLDR, Clock Input	Test to V ⁺
Power Dissipation	
Ceramic Package	1000 mW
Plastic Package	800 mW
Operating Temperature	0°C to +70°C
Storage Temperature	-65°C to +160°C
Lead Temperature (Soldering, 60 sec)	300°C

ICL7117

Supply Voltage V ⁺	+6V
V ⁻	-9V
Analog Input Voltage (either input) (Note 1)	V ⁺ to V ⁻
Reference Input Voltage (either input)	V ⁺ to V ⁻
HLDR, Clock Input	Gnd to V ⁺
Power Dissipation	
Ceramic Package	1000 mW
Plastic Package	800 mW
Operating Temperature	0°C to +70°C
Storage Temperature	-65°C to +160°C
Lead Temperature (Soldering, 60 sec)	300°C

Here are your **free FactCards!**

Introducing Hands-On-Electronics® FactCards. Each issue, Hands-On-Electronics® will present 3 new FactCards, each dealing with one of a variety of electronics topics. Some will deal with electronics basics, some will deal with discrete components, some will deal with IC's, and some will deal with circuits and applications.

All will contain the type of information electronics hobbyists need, but sometimes must search to find. With FactCards, you can find that information in a hurry.

Clip your cards, save them, and start building your **FactCards library today!**

Hands-on Electronics

STATIC ELECTRICAL CHARACTERISTICS

CHARACTER- ISTIC	CONDITIONS			LIMITS at 25°C (Typ.)	UNITS
	V _{DD}	V _{IN}	V _{DP}		
Quiescent Device Current, I _{DD} Max.	—	0.5	5	0.04	μA
	—	0.10	10	0.04	
	—	0.15	15	0.04	
	—	0.20	20	0.08	
Output Low (Sink) Current I _{OH} Min.	0.4	0.5	5	1	mA
	0.5	0.10	10	2.6	
	1.5	0.15	15	6.8	
Output High (Source) Current, I _{OH} Min.	4.6	0.5	5	-1	mA
	2.5	0.5	5	-3.2	
	9.5	0.10	10	-2.6	
Input Current I _{IN} Max.	—	0.18	18	±10 ⁻⁶	μA

CHARACTER- ISTIC	CONDITIONS			LIMITS at 25°C (Typ.)	UNITS
	V _{DD}	V _{IN}	V _{DP}		
Output Voltage: Low-Level, V _{OL} Max.	—	0.5	5	0	V
	—	0.10	10	0	
	—	0.15	15	0	
Output Voltage: High-Level, V _{OH} Min.	—	0.5	5	5	V
	—	0.10	10	10	
	—	0.15	15	15	
Input Low Voltage, V _{IL} Max.	0.5,4.5	—	5	—	V
	1.9	—	10	—	
	1.5,13.5	—	15	—	
Input High Voltage, V _{IH} Min.	0.5,4.5	—	5	—	V
	1.9	—	10	—	
	1.5,13.5	—	15	—	

MM53126 ELECTRICAL CHARACTERISTICS

Sym	Parameter	Conditions	Min	Typ	Max	Units
V _{DD}	Supply Voltage		6.5		7.5	V
I _{DD}	Supply Current	V _{DD} = 9V No key depressed		10	20	μA
		V _{DD} = 7V Valid key depressed			10	mA
	Oscillator Frequency	C _T = 47pF 2%; R _T = 33k 1%, R _S = 33k 5%	160		220	kHz
	Serial Out Logic "0" Logic "1"	1 Sink = 0.2mA	1.0		0.2	V
		1 Source = 0.2mA			V	

MM53226 ELECTRICAL CHARACTERISTICS

Sym	Parameter	Conditions	Min	Typ	Max	Units
V _{DD}	Supply Voltage		6		10	V
I _{DD}	Supply Current	V _{DD} = 9V No key depressed		10	20	μA
		V _{DD} = 7V Valid key depressed			10	mA
	Oscillator Frequency	C _T = 47pF 2%; R _T = 33k 1%, R _S = 33k 5%	160		220	kHz
	Serial Out Logic "0" Logic "1"	1 Sink = 0.2mA	1.0		0.2	V
		1 Source = 0.2mA			V	

ELECTRICAL CHARACTERISTICS

Characteristics	Conditions	Typ	Units
Zero Input Reading	V _{IN} = 0.0V Full Scale = 200.0mV	±000.0	Digital Reading
Ratiometric Reading	V _{IN} = V _{REF} V _{REF} = 100mV	999/1000	Digital Reading
Rollover Error	-V _{IN} = +V _{IN} ≅ 200.0mV	±0.2	Counts
Linearity	Full Scale = 200mV or Full Scale = 2.000V	±0.2	Counts
CMRR	V _{CM} = ±1V, V _{IN} = 0V Full Scale = 200.0mV	50	μV/V
Noise (Pk - Pk)	V _{IN} = 0V Full Scale = 200.0mV	15	μV
Leakage Current @ Input	V _{IN} = 0V	1	pA

Characteristics	Conditions	Typ	Units
Zero Reading Drift	V _{IN} = 0 0°C < T _A < 70°C	0.2	μV/°C
Scale Factor Temperature Coefficient	V _{IN} = 199.0mV 0°C < T _A < 70°C (Ext. Ref. 0 ppm/°C)	1	ppm/°C
V+ Supply Current	V _{IN} = 0	0.8	mA
V- Supply Current (7117 only)		0.6	mA
Analog Common Voltage	25kΩ between COMMON & pos. Supply	2.8	V
Temp. Coeff. of Analog Common	25kΩ between COMMON & pos. Supply	80	ppm/°C
Input Resistance, Pin 1		70	kΩ

For new ideas in electronics read **Radio-Electronics®**

During the next 12 months

- Radio-Electronics® will carry up-to-the minute articles on:
- hobby computers
 - solid-state technology
 - TV games • Video
 - color TV • stereo
 - test equipment
 - radio
 - radar detectors
 - industrial electronics
 - servicing
 - TV-radio-stereo
 - experimenter circuits
 - exceptional construction projects

Don't take a chance on missing even one issue. Subscribe now and save!



NEW IDEAS AND INNOVATIONS IN ELECTRONICS

The newest ideas and innovations in electronics appear in Radio-Electronics®, Keep up-to-date!

Subscribe Today!

ELECTRONIC CRICKET

It may not be a locust, but it's sure to plague those who hear its intermittent chirp

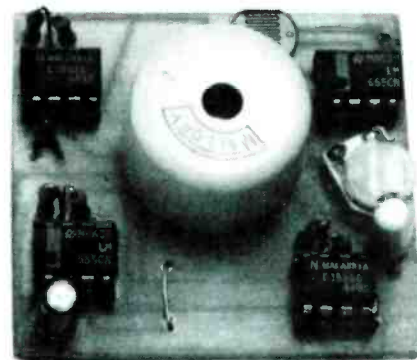

By Ronnie Shafer

IMAGINE YOU'VE JUST SPENT AN EVENING AT A FRIEND'S house. Before leaving, you plant a devilish little circuit—the *Electronic Cricket*—that begins its annoying chirp, chirp, chirp as soon as the lights go out (say at bedtime). And it doesn't know when to quit. Your victim may stomp the floor or throw a shoe at it, but it keeps on chirping. Eventually, the victim, reaching the end of his or her rope, will get up in an attempt to locate the little devil. But just as soon as the lights go on, silence...Nothing, *nada*, zilch.

The Electronic Cricket is a light-sensitive circuit that turns on in the dark or in dim light, but turns off when exposed to full room light. Use your imagination as to what happens next: You had better hope that your victim can take a joke, or he may smash the bug, as well as the prankster.

Aside from initiating a harmless prank (unless you're on the receiving end), the project is educational in that it demonstrates three different ways that the 555 can be used: As an oscillator (two comprise the circuit that makes the chirp); as a timer, which provides the pause between chirps; and as a variable-threshold Schmitt trigger, or switch.

How it Works

Figure 1 is a schematic diagram of the Electronic Cricket. Note that the circuit is nothing more than a few 555 oscillator/timers strung together, each controlling the operation of the

one that follows. A 555 contains two comparators that set the upper (threshold) and the lower (trigger) limits of the IC, a flip-flop or latch (which controls or determines the output status), an amplifier to provide output drive, and two transistors that handle the reset and discharge operations of the device.

The first 555 (U1), in conjunction with R8 (a cadmium-sulfide photo cell), forms a photo-optic trigger that activates the circuit when the light reaching R8 drops to the desired level. Resistor R1 is the circuit's sensitivity control, the setting of which determines the voltage at which triggering takes place. Resistor R8, a photo cell, connected across the +V, threshold, and trigger inputs of U1, is used to detect ambient room light. In the dark, R8 has a resistance of about 100 ohms; under full light, it has a maximum resistance of about 500K.

As the light level detected by R8 falls, the resistance across R8 begins to increase, thereby pulling the trigger input of U1 low. That low, being below the internally set threshold of the 555, forces the output of U1 high. (The output of U1, being under the direct control of R8, remains high as long as the lights are turned off or at a low level.) The high output of U1 is applied to the +V and reset inputs of U2, enabling the rest of the circuit.

At that point, U2 begins to oscillate. The alternating output

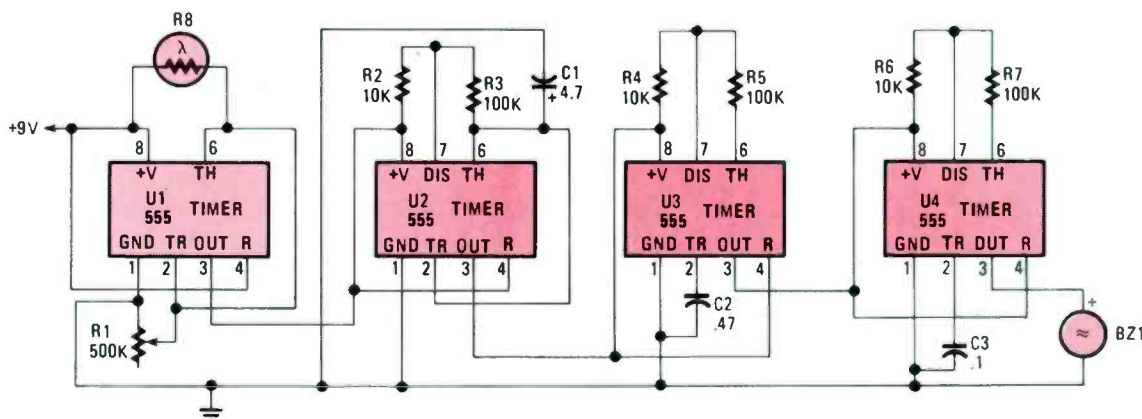
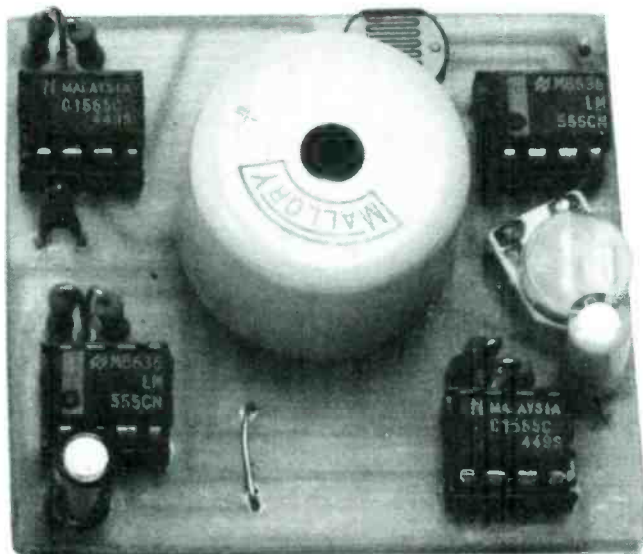

Fig. 1—The schematic diagram of the Electronic Cricket shows that the circuit is little more than four 555 oscillator/timers strung together, each controlling the operation of the one that follows.



Shown here is the Electronic Cricket's fully assembled printed-circuit board. If you look closely, you can see three pairs of vertically-mounted fixed resistors.

of U2 is then fed to U3 (the second oscillator) at its +V and reset inputs, turning it on. Note that U3 is activated only while the output of U2 is high. The output of U3 is then fed to the +V and reset inputs of U4, which determines the rate at which the chirping sound is produced, and provides sufficient drive for the buzzer, BZ1.

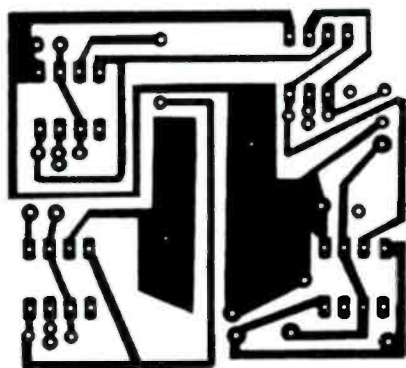

Fig. 2—The author's printed-circuit foil pattern for the Electronic Cricket is shown here full scale. Note that other construction techniques are also acceptable.

PARTS LIST FOR THE ELECTRONIC CRICKET

- U1—U4—555 oscillator/timer, integrated circuit
- C1—4.7- μ F, 25-WVDC radial-lead electrolytic capacitor
- C2—0.47- μ F, 50-WVDC radial-lead electrolytic capacitor
- C3—0.1- μ F, 35-WVDC Tantalum capacitor
- R1—500,000-ohm, PC-mount potentiometer
- R2, R4, R6—10,000-ohm, 1/4-watt, 5% resistor
- R3, R5, R7—100,000-ohm, 1/4-watt, 5% resistor
- R8—Cadmium-sulfide photocell, 100-ohms full light, 500K dark (Radio Shack No. 276-1657)
- BZ1—Miniature buzzer (see text)

Printed circuit or perboard materials, IC sockets (optional), 9-volt transistor-radio battery, battery snap, solder, etc.

Putting it Together

There is nothing critical about the circuit, so any construction method can be used to assemble the project. The author's prototype unit (including the buzzer) was assembled entirely on a printed-circuit board measuring about two-inches square. The author's full-scale printed-circuit foil pattern, which may be copied and used to etch your own circuit board, is shown in Fig. 2.

Once you've obtained the parts (see the Parts List), install them on the board using Fig. 3 (the parts-placement diagram) as a guide. Start by installing the IC sockets (but do not install any of the ICs yet), then mount the photocell (R8). Next install potentiometer R1 and the rest of the resistors, followed by the capacitors. Note: Because of the tight spacing of the author's layout, it is necessary for the fixed resistors to be vertically mounted to the board (see photo).

Now mount the buzzer (BZ1) at the center of the board as shown. The author used a Mallory MCP320B2 miniature 3- to 30-volt buzzer, but any low-power buzzer with an operating voltage within that range—6, 9, or 12 volts—that will fit the space can be used. If the buzzer chosen for the project is the type that has insulated wire leads, it will be necessary to clip the leads as short as possible, and solder the leads to the appropriate foils, as you would with any other printed-circuit-mounted component. If you can find one with the proper rating that has pins instead of leads, construction will be all the more easy.

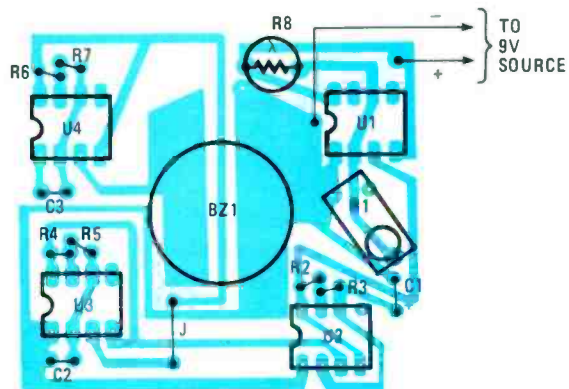

Fig. 3—Because of the tight spacing of the printed-circuit layout, it was necessary to mount the fixed resistors (R2 through R7) vertically on the board.

Install the jumper connection (the jumper is labeled "J" in Fig. 3), and attach a battery snap. Finally insert the ICs in their sockets, and check your work. There is very little that can go wrong with the circuit, short of misorienting an IC or C1, or reversing the battery's polarity, but it is always best to check the circuit before powering it up. Once you are satisfied that you've made no construction errors, attach the battery and see what happens.

If the circuit begins to chirp at full room light, slowly adjust the sensitivity (via R1) downward, until the chirping ceases. Turn out the light, and wait a second or two. If the circuit begins to chirp, turn on the lights to make sure that the chirping stops under full-lighting conditions. If the Cricket performs as expected, you are all set. If the circuit doesn't start chirping, adjust potentiometer R1 upward or downward, until it does.

Once the circuit is operating properly, you are ready to have some fun. Just try not to be too big a "pest" with your new toy.

Shopping for an antenna for your hobby communications setup? At least one of these is sure to suit your needs!

5 CLASSIC ANTENNAS

By W. Clem Small, KR6A, CET

IN RADIO LISTENING, OR what's called "monitoring" by the more serious enthusiast, your sole link with the world outside your own radio is the antenna that's used with your receiving system. If the antenna does its job well, the rest of your communications system can then perform to its full capability. But, even with the finest receiving equipment available today, a poor antenna may make really-good reception an impossibility.

And, although any piece of wire will function as an antenna to a certain extent, it's just as true in communications work as in any other field that *You gets what you pays for*. When the going gets rough, a well-designed antenna—one selected for the job you wish it to perform—increases the probability of your hearing the stations that you want to copy.

And so, in view of the importance of having a decent antenna as part of your receiving system, let's take a look at some antennas that are perennial favorites with radio experimenters, monitoring buffs, SWLs, and other radio hobbyists. And while we're at it, let's also look at why those simple designs remain so popular over the years.

Among radio hobbyists are several types of antenna—random-length antennas, half-wave dipole, the quarter-wave vertical, loop antennas, and active antennas—that have come to be what we might call *standards*, all of which are used and relied upon by many radio enthusiasts. Those antennas, all relatively easy to put together and maintain, give a good account of themselves in the applications where they have earned their reputation. We'll discuss each of the forementioned types, so that you can better determine what's best for you.

Random-Length Antennas

The random-length antenna (see Fig. 1) has long been used for work on the medium-frequency (300 to 3000 kHz) and high-frequency (3 to 30 MHz) bands. Table 1 gives the wavelengths and band names according to their frequency range, which can be beneficial in the construction of your system. And there's an old radio-operator's *rule-of-thumb* that the higher, longer, and the more in-the-clear an antenna is mounted, the better it performs.

Unfortunately, it often turns out that the space available for such an installation is far too limited to erect antennas in strict accordance with that rule. Thus, to maximize performance, we do the best we can—erect the antenna as high and as long as possibly, and mount it with as few obstructions as the

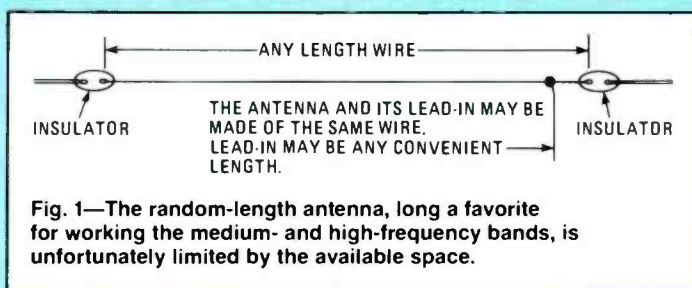

Fig. 1—The random-length antenna, long a favorite for working the medium- and high-frequency bands, is unfortunately limited by the available space.

situation allows.

Variables, like available space in which to erect the antenna; what sort of poles, trees, or other supports for the antenna are available in that space; and how much wire we can afford to buy are the factors that help to determine antenna construction.

In effect, the random-length antenna is a compromise. It's used when there isn't enough space to put up a bigger antenna, or when you don't want or need to use a more complex design. Random-length antennas go up quickly and easily, and require little planning for their construction. But don't sell them short! Random-length antennas have enjoyed much success on the medium-wave and shortwave bands. And keep in mind that, as the old rule implies, the higher, longer, and more in the clear they are, the better they usually work.

I have found that a really long (200 feet or more) and high (40 or more feet up) random-length antenna is hard to beat as a general all-around antenna for the medium and high frequency bands.

Using an Antenna Tuner

With the random-length antenna, as with the quarter-wave dipole that will be discussed a little later on in this article, you can use a so-called *antenna tuner* to peak the strength of the signals that it receives. But in receive-only applications, using such a tuner is seldom worthwhile. The noise that accompanies the signal is peaked along with the signal, and the end result is usually no real discernible improvement in the output signal.

When the antenna just isn't feeding a significant portion of its received signal to the feed line, a tuner can help sometimes. A tuner can also give you some selectivity to help prevent "intermodulation." Intermodulation can cause the receiver to respond to a very strong signal up and down the dial when, in fact, that signal is being received at only one frequency.

TABLE 1—WAVELENGTH AND FREQUENCY BANDS

Frequency	Band	Wavelength
30 to 300 kHz	Low Frequency	Long Wave
300 to 3000 kHz	Medium Frequency	Medium Wave
3 to 30 MHz	High Frequency	Short Wave
30 to 300 MHz	Very High Frequency	Very Short Wave
300 to 3000 MHz	Ultra High Frequency	Ultra Short Wave

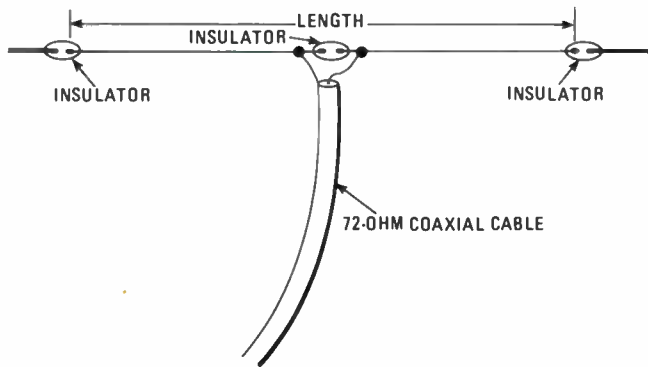

Fig. 2—The half-wave dipole (which is “tailor-made” for the band of its intended use) has enjoyed popularity among radio buffs for many decades, and the dipole might aptly be called a two-band antenna. The wire element of the antenna is actually just ½-wavelength long at the band for which the antenna is designed.

Antenna tuners are certainly not a necessity and many radio hobbyists have had a lot of success using nothing more than an all-band receiver and a random-length antenna. But the other four of the Big Five antennas have their places in the sun, too, so let’s move on.

The Half-wave Dipole

One antenna that has enjoyed popularity among radio buffs for many decades is the half-wave dipole (see Fig. 2). The wire element of the antenna is actually just ½-wavelength long at the band for which the antenna is designed. The dipole might aptly be called a two-band antenna, in that it also functions well at frequencies three times that for which it was designed.

By being specifically cut-to-length, each dipole is “tailor-made” for the band of its intended use. Thus, the antenna is more responsive to signals in that band than those in other bands. That selective characteristic can be useful in rejecting strong out-of-band signals that might otherwise come through in the form of intermodulation.

The dipole is used for frequencies from the lower end of the shortwave band up to the UHF band, but is rarely used at frequencies much below the shortwave bands—a range in which the response of the dipole is adversely affected, al-

though not pronounced. In use, such antennas seem to give a relatively non-directional response, except in the direction of the nulls (direction of very poor responsiveness).

Sometimes one of those nulls can be put to good use, by mounting the antenna in such a way that one end points in the direction of the interference. The interference might be electrical noise from an industrial area, or be caused by the signals of some nearby transmitter. If the antenna is oriented so that one of its nulls is directly facing the source of interference, a high degree of interference attenuation can be achieved.

It should be obvious by now that you should never point the end of the dipole in the direction of the station to be received. Such action might place the desired station in a null, thereby obscuring the signal. Placing the antenna broadside to the transmission is the best way to avoid nullifying the station that you wish to receive. When used at three times its design frequency, the dipole has six nulls spread throughout its reception pattern. But because the nulls are narrow, the dipole tends to give good overall coverage.

Figure 2 shows how to build a dipole antenna for the band that you want to monitor. Mount the antenna as high and as free of obstructions as possible. For VHF and UHF, try mounting the antenna vertically, then re-orient it horizontally. You’ll find that one orientation gives better reception than afforded by the other—which is due to differing polarizations on the VHF and UHF bands.

Quarter-wave Verticals

For non-directional coverage of a single band, the quarter-wave vertical is a good choice. Its 360-degree reception pattern gives good all-around reception with no nulls. Figure 3 shows the two types of quarter-wave vertical that we’ll consider—the grounded quarter-wave vertical and the ground-plane type.

The quarter-wave vertical has long been the workhorse of the industry (so to speak). From the tall steel towers seen at AM broadcast stations to the small UHF ground-plane antennas mounted atop the homes of monitoring buffs, the quarter-wave is used on most bands, and in most types of radio service. But when you get down to the low end of the shortwave band, and into the AM band, the height of a quarter wavelength is so tall that full quarter-wave verticals are generally not used. For example, near the middle of the AM broadcast band (1 MHz) the height of a quarter-wave antenna is 234 feet! Yes, AM broadcast stations put them up, but they have a lot more money for antenna towers than most of us do.

On the other hand, as we get into the mid

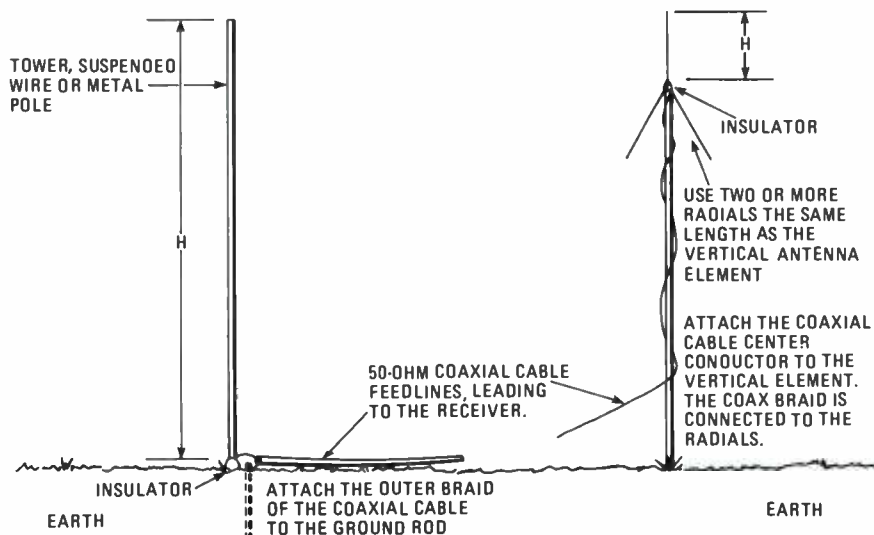

Fig. 3—For non-directional coverage of a single band, the quarter-wave vertical (with its 360-degree reception pattern) gives good all-around reception with no nulls. Shown here are two types of verticals—the grounded quarter-wave vertical and the ground-plane type.

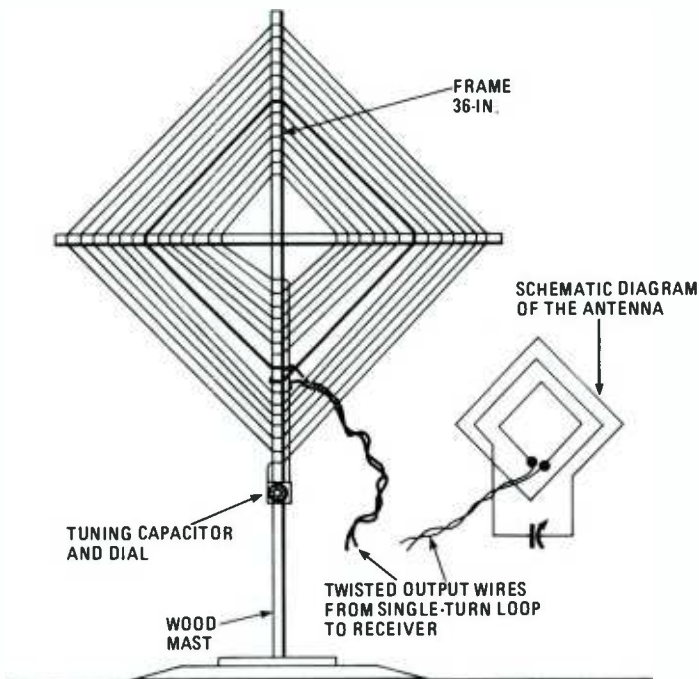

Fig. 4—The loop antenna, the most directional of the Big Five, is small enough to be easily rotated by hand, allowing its directional characteristic to be optimized. Each loop is designed for a specific band, and is usually tunable over that band by use of a variable capacitor.

frequencies of the shortwave band and higher, the height of a quarter-wave antenna becomes an easily attainable goal for the radio hobbyist. And as we move to the VHF and UHF bands, the size and convenience of the quarter-wave antenna makes it extremely popular.

A quarter-wave vertical antenna has less gain than the dipole or random-length antenna, translating into a somewhat lower signal input to your receiver. Nevertheless, the quarter-wave's gain is adequate for many applications.

Like the dipole, the quarter-wave is cut-to-length for the intended band of operation, and because of that some degree of rejection to out-of-band signals. Vertical antennas are often thought of as "DX" (distant station) antennas, because they're particularly responsive to signals arriving at your location at the low angles, which are characteristic of the signals of many shortwave DX stations. But to really perform well as a DX antenna, the quarter-wave must have a very good ground connection.

When putting up a quarter-wave vertical, you must first determine the frequency at which it is to operate, and from that calculate the antenna's proper height (see Fig. 3). To illustrate, let's say that our objective is quarter-wave vertical for operation at 10 MHz. Armed with that information, the proper height of the antenna (in feet) is calculated by dividing 234 by the operating frequency (234/10), which (for our example) works out to 23.4 feet.

If you make the grounded vertical version, be sure that your ground connection is a very good one. In such antennas, the ground connection is most often a set of buried radials (counterpoise), radiating out from the antenna's base like the spokes of a wheel. Such a system is recommended for use with the antennas presented here when used in transmitting stations. But for receive-only systems, the effort of putting in counterpoise radials may be more than we're willing to invest in the antenna system. In which case, a grounding rod driven

ANTENNA REFERENCES

Antennas: Selection and Installation, by Alvis J. Evans—A simple introduction to the use and selection of antennas used for AM, FM, TV, satellite reception, cellular phone, and shortwave listening. The book is published by Master Publishing, Dallas, TX, and is available through Radio Shack.

The Shortwave Listener's Antenna Handbook, by Robert J. Traister—A simple introduction to shortwave antennas. Published by TAB Books, Blue Ridge Summit, PA.

Antenna Data Reference Manual, by Joseph J. Carr—This manual gives the appropriate lengths for the elements of a variety of antennas across the medium-frequency and high-frequency bands. Also included are computer programs that may be used in antenna work, chapters on antenna testing, antenna construction, and related topics. Published by TAB Books, Blue Ridge Summit, PA.

The Radio Amateur's Antenna Handbook, by William T. Orr and Stuart D. Cowan—A good practical survey of antenna selection and construction. Published by Radio Publications of Wilton, CT.

The ARRL Antenna Book, edited by Gerald Hall—More technical than the others listed, but has a great deal of practical information and gives very good coverage of antenna design, construction, testing, and signal propagation. Published by the ARRL, Newington, CT.

into the soil is used, which results in somewhat reduced performance compared to those having a set of radials.

Radials can also be mounted above ground, making it essentially a ground-plane antenna hovering just above the ground. When mounted above ground, the radials should be electrically insulated from the ground, except where they join the feed line. Above ground only two to four radials are used. The fact that we can use above-ground radials with a vertical antenna, rather than the actual ground, allows the mounting of the ground-plane antenna far above your location—often atop buildings and towers—where their effective area of coverage is greater.

Loop Antennas

Loop antennas (see Fig. 4) are the most directional antennas of the Big Five, while being small enough to be easily rotated by hand—which allows the directional characteristic of the antenna to be readily apparent. Each loop is designed for a specific band, and is usually tunable over that band by use of a variable capacitor. Coverage is generally within the low to medium frequency range, which includes the AM broadcast band.

Like the dipole, the loop antenna has two nulls in its response, allowing you to eliminate interference by rotating the loop until the null is precisely in the direction of the interference. Nulls in the antenna's response pattern have led to its use in direction-finders, a task to which it is well suited. Persons who enjoy DXing on the broadcast band often find the directional characteristics of the loop useful, particularly in nulling out interfering signals that occupy the same frequency as the station they want to hear.

A major convenience of the loop antenna is that it may be made small enough to fit on a table near your station or right

(Continued on page 106)

THE RUBBER CRYSTAL OSCILLATOR

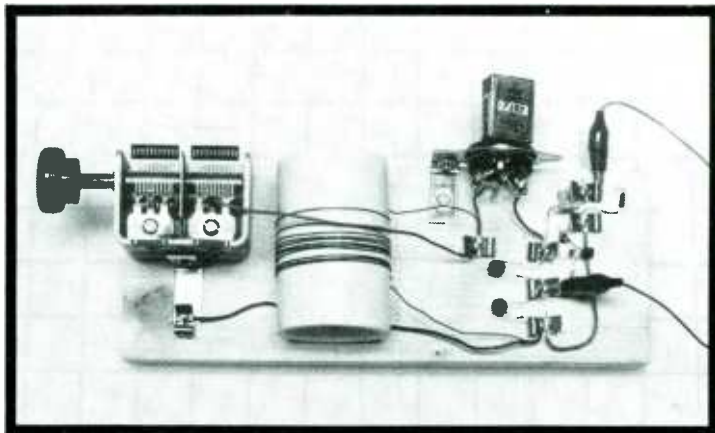

Imagine how nice it would be to have a stable, adjustable, high-frequency oscillator among your wares. Imagine no more because you can start construction now.

By Larry Lisle, K9KZT

COIL AND CAPACITOR OSCILLATORS TUNE, BUT TEND TO drift; crystal oscillators are rock stable, but can't be tuned. Actually, that's not quite true. You can combine the two and have an oscillator that's very stable, but can be tuned a little—the *Rubber Crystal Oscillator*.

The Rubber Crystal Oscillator is a solution looking for problems. How about running the output into a mixer and beating the signal against a fixed crystal, a viola, or any wide-range audio source. How about using it as a local oscillator for a superheterodyne receiver to cover a limited portion of the high-frequency spectrum such as a shortwave broadcast band? How about using one as an oscillator for a direct-conversion ham receiver or a high-frequency BFO for a receiver without one? Or how about using one as a master oscillator for a ham transmitter? The Rubber Crystal Oscillator will do the job! It's a neat addition to the experimenter's bag of electronic tricks.

Background Info

The tunable crystal oscillator actually predates the fixed-frequency oscillator. Early on in the experimentation with

quartz crystals, it was found that a crystal in parallel with the tuning capacitor of a conventional oscillator would tend to stabilize the oscillator's frequency when the oscillator was tuned near one of the crystal's natural frequencies.

After Cady, Pierce, Miller, and others discovered how to build a stable crystal oscillator in the 1920's, the Rubber Crystal Oscillator faded into obscurity. The reasons aren't hard to understand. In the 1920's, the need for stable oscillators operating on known frequencies was overwhelming. For radio amateurs, just finding the bands was a real challenge, let alone finding a particular frequency!

Later, another factor kept the tunable crystal oscillator from becoming a commercial proposition. Each crystal behaves slightly differently in a tunable circuit. That doesn't lend itself to mass production since each device would have to be calibrated individually.

The Oscillator

Let's get to the nuts and bolts. You can make a variable-frequency crystal oscillator by simply hanging a crystal across the tuning capacitor of a conventional oscillator. I've built them using the Hartley, Colpitts, and Clapp circuits, and they all work—with plated crystals. None would work with the cheaper pressure-mounted FT-243 types. I think that's because slight surface imperfections are hidden by the plating, or perhaps it's because of the lack of a gap between the holder and crystal. Fortunately, the question is moot because the circuit in Fig. 1 will work with either!

As you can see, the circuit is similar to a Colpitts oscillator with a crystal in series with the LC network. With the plates of the tuning capacitor wide open, the circuit oscillates at about the natural frequency of the crystal. As the plates are slowly meshed, the frequency decreases, dropping at a faster and faster rate until oscillation ceases (when the plates are about half closed). Continuing to close the plates will cause oscillation at near the natural frequency again.

With the values shown and 40-meter crystals picked at random, the frequency can be lowered 50 to 100 kHz. As the operating frequency moves farther away from that stamped on

(Continued on page 98)

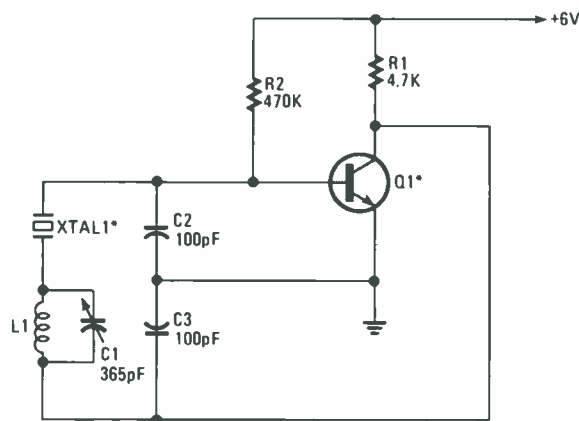

*SEE TEXT

Fig. 1—The *Rubber Crystal Oscillator* combines some of the best features of a stable crystal oscillator and a tunable Colpitts. It can be used in receivers, transmitters and test gear.

KEEP THAT AUTO CASSETTE DECK IN TIP-TOP SHAPE

A defective cassette-player radio may cause you to start the day off wrong when driving to work. The most common cassette player problems are found in this article.



By Homer L. Davidson

THE CASSETTE MUSIC COMES TO A SUDDEN HALT WITH no rewind or fast-forward movement. So you push the FM button to hear only an erratic news announcer as you pass into another lane on your way to work. In disgust you flip the radio to AM to get the local weather report. It sure looks dark and gray out. Sometimes when adjusting the volume control the voice cuts up and down. Nothing is going right this morning, so you eject the cassette and some of the tape is left in the machine. What a mess!

Incidents like that happen everyday to someone, but why me? You want to give it a kick or hit it with the hammer, except both are out of reach. So you calm down by cramming several lemon drops into your mouth. Enough is enough—tonight you are going to rip that baby out and work it over. Who me? Yes, just about anyone with nimble fingers and a little patience can keep that auto cassette player in tip-top shape (with a little help from this article).

Where to Start

Like the electronic technician, you take the symptom, isolate the probable section, and locate the component on the schematic and player. You should have a schematic diagram to locate the suspected components. Just check the service instructions as a small diagram may come in the package. Of course, you may need a magnifying glass to see all the wiring. If you have a few tools and a pocket VOM or DMM, you are in business, so to speak.

Cleaning up the tape head may solve distorted or weak cassette music. Wiping off the motor belt and pinch roller may cure some speed problems. No rotation may result from a broken belt or defective cassette motor. Intermittent cassette music may be caused with broken tape head connections. Distorted and weak music may be solved with accurate volt-

age measurements upon the suspected output transistors or IC components. Now, let's take one step at a time, before we fall flat on our face, with a few common problems.

Clean Up Time

Sometimes just a good clean up with a cleaning stick and alcohol may solve a lot of problems. Clean off the front of the tape head to prevent weak, dead or distorted music. Get all the oxide off the small gap areas of the tape head. Those areas are very small and can easily be plugged with stubborn oxide dust. Clean up all excess oxide underneath and around the tape head assembly.

Wipe off the motor drive belt with alcohol and cloth. Inspect the rubber belt for loose or cracked areas. Clean off the motor pulley and capstan flywheel with cleaning stick.

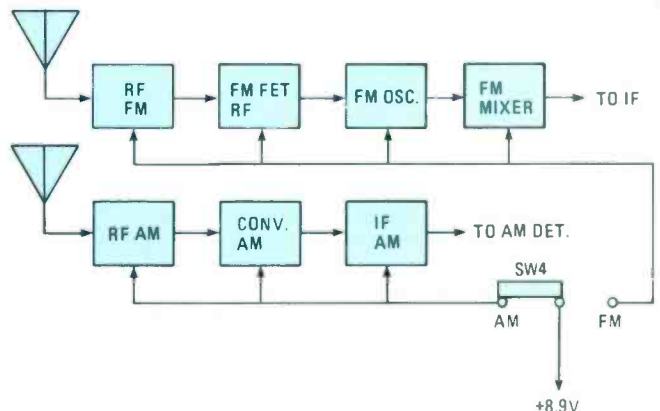
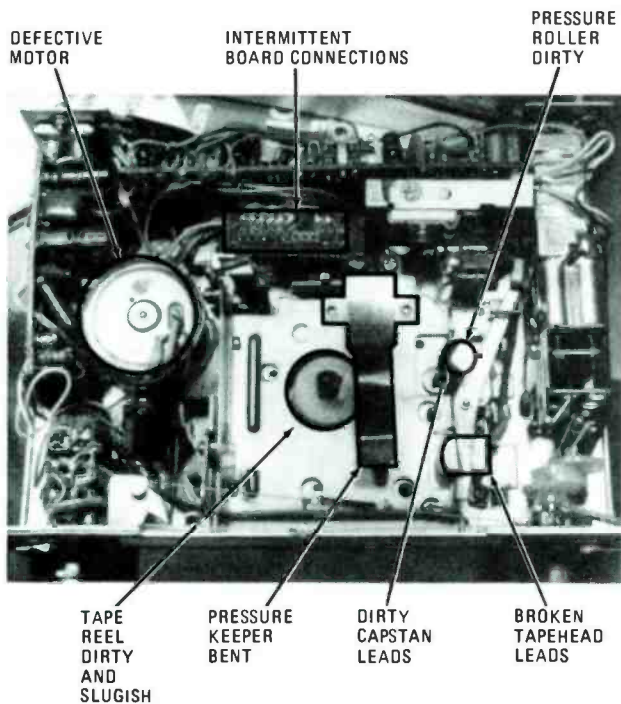

Fig. 1—Check the AM-FM slide or push-button switch with erratic AM or FM. It may simply need cleaning. Often the AM-FM switch provides DC voltage to the front-end components.



Here are various places to look for certain symptoms and problems. One of them may occur in your cassette player.

Whirl the flywheel with fingers and notice if it rotates freely. Sometimes a gummed up flywheel bearing slows down the movement of tape. Remove the dry capstan/flywheel, clean up the bearing area, and apply a dash of light phono grease or vaseline.

Often, the motor belt and capstan are found under the cassette assembly. Remove the bottom cover to clean up the moving components. Sometimes the whole cassette assembly must be removed to get at the motor belt. Remove three or four small screws holding the cassette assembly to the bottom one-piece metal cover. Always mark down any wire leads or components you must remove to get the assembly free for clean up.

Erratic FM

When the AM or FM reception appears intermittent or erratic after switching to either channel, suspect a dirty AM-FM switch. In some radio cassette players the selection is made with a push button or slide type switch, while in the later digital models the bands may be changed by pushing in on the selection tuning knob. Often, the AM-FM switch applies voltage to the respective circuits (see Fig. 1).

Whatever switching system, the silver contacts must be cleaned. Often, you can quickly tell if the switch is dirty by pushing and slightly moving the switch button after switching to the correct program. When touched, the reception becomes intermittent or quits. Simply by moving the knob or button, the station returns.

Sometimes in the small AM-FM radio, cleaning fluid may be sprayed into the switch area, outside of the radio. You must remove the top cover to get at the push button or switch assembly. Usually, the push buttons are set back inside the front cover. Spray cleaning fluid down inside the AM-FM switch assembly. Work the switch back and forth to help clean up the contacts. Clean up all the push button and switches located within the radio. Keep the spray nozzle away

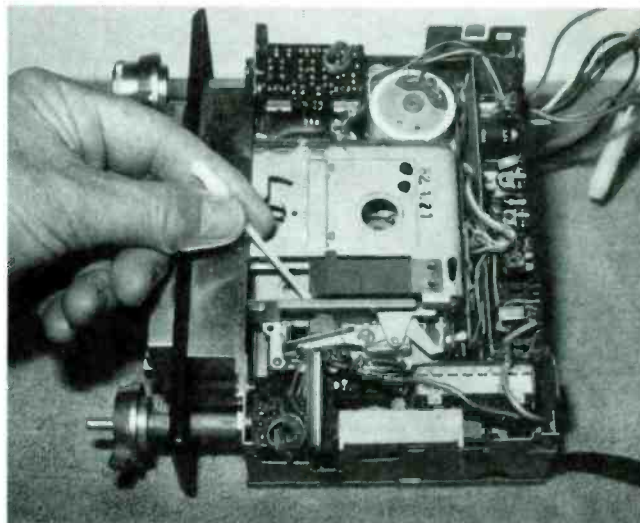

A good clean up of the tape head and surrounding parts may save a few tapes and cure many tape-speed problems.

from the motor belt and capstan/flywheel assembly; the chemicals in the spray can damage them.

Rough Volume Control

While you have the cleaning spray can out, give the volume control a squirt or two. After the radio has been used for several years the volume control seems to wear and get dirty at the comfortable volume setting. Sometimes the sound may cut up and down with a noisy control. The life of the control may be extended for many months with a good clean up.

Remove the top cover and place the plastic tip into the opening of the control where the contacts come out. You can not clean the volume control from the outside of the radio, by squirting cleaning fluid into the shaft area. The control shafts are too long. You may have to remove both covers to get at the opening of both stereo volume controls.

Give each control a couple of squirts and rotate the volume-control shaft. Do that at least twice for each control section. Remember, there are two volume-control sections for the stereo output channels. Likewise, clean up the balance and tone controls while you are at it. If that doesn't do the job, replace the entire volume, tone, and switch component.

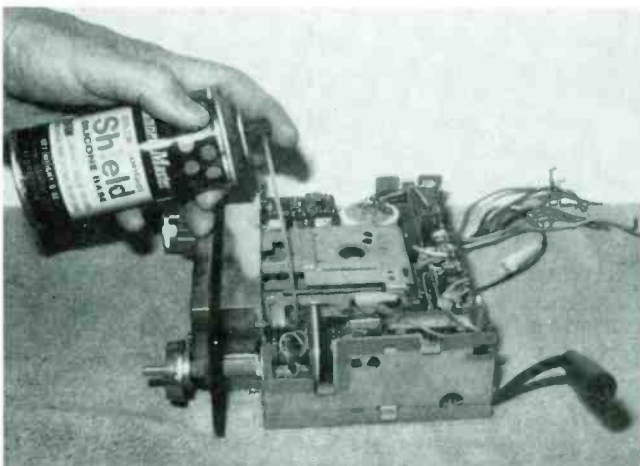

Clean up that noisy volume control with an extension tube down inside the contact terminals. Rotate the control shaft after spraying to clean up dirty and worn contacts.



The broken belt, belt off, or a defective cassette motor may prevent tape rotation. Check the price of a new motor before ordering one to make sure it's worth it.

Dead—No Tape Action

Improper or no tape rotation may result from a missing motor belt, broken belt, or a dead motor. Often, the motor belt will come off when the tape player is started up with a very loose rubber belt. After several years the belt will stretch and crack. Usually, the broken belt is found loose down under the whole cassette tape assembly.

Slow speeds may be caused with a large belt or oil upon the rubber area. Remove the motor drive belt and clean both sides with alcohol and cloth. One method the electronic technician applies in checking out a loose belt is to hold the capstan and belt while the motor is rotating. If the motor pulley turns inside the belt, the belt is too loose. In case the motor will not rotate inside the belt area, you may assume the belt is not slipping. Check the motor pulley for a shiny surface indicating the belt is slipping. Inspect the motor belt for cracked areas.

The dead motor may not rotate because of a lack of voltage at the motor terminals or if the motor is defective. Measure the voltage across the motor terminals (12–14 volts). Check the tape motor switch, isolation resistor and voltage source with improper voltage at the motor (see Fig. 2). Take a continuity measurement, using the probes of an ohmmeter set to the low-ohm scale, across the motor when voltage is found at the motor terminals and the motor refuses to rotate. All resistance measurements should be made without voltage applied to the player. The reading should be a fraction of an ohm and vary only slightly as you rotate the motor's shaft.

The defective motor may operate intermittently. Sometimes the player starts up and other times it's dead. Remove the motor belt, apply power to the player and spin the motor pulley. The motor will either take off or pull slightly as it is rotated. Often, tapping the end belt of the motor after operating for several minutes, the speed may appear erratic. Replace the motor if it plays normally after rotating the motor pulley or is intermittent.

Intermittent Tape Head

Suspect broken wire connections tied to the tape head with intermittent sound. The sound may cut off and on in each channel or only in one audio speaker. Often, one channel may have only a hissing sound while the other speaker is normal. The intermittent music may occur at the beginning of the tape. A loud rushing noise indicates the tape head is open in that channel.

Check the tape head for broken wire connections (Fig. 3).

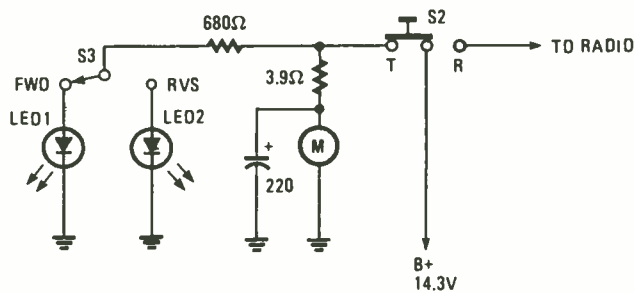

Fig. 2—Check the cassette switch and isolation resistor when no voltage is found at the motor terminals. Replace the motor if tape movement is erratic or intermittent.

You may find separate wires or two shielded cable wires connected to the tape head. Double check each soldered connection. The outside shield may be used as the common return wire. Solder up all wires with a low wattage soldering iron. Make sure no flexible wire ends touch the adjoining connection.

Improper Rewind

Improper rewind or fast forward may result from oil or residue upon the motor drive belt. Poor pressure of the idler wheel may cause improper rewind and fast forward. Check the idler wheel for sluggish or uneven rubber drive area. Clean off the motor pulley, belt and flywheel for slow or uneven fast forward.

A good clean up and lubrication of the idler pulley and motor drive areas solves most erratic or slow rewind and fast forward operations. Clean off each spindle or turntable drive pulley with alcohol and a cleaning stick. A drop of light oil on each pulley bearing may help. Do not over lubricate or let the oil drip upon rubber pulleys or drive belt.

Spits Out Tape

Spilling out of tape may be caused by the erratic or stopped take-up reel assembly. The rounded or uneven pinch roller may spill out tape. Check the pinch roller for sticky or excessive packed oxide. Clean off the rubber pinch roller when cleaning up the tape head. Inspect the pinch roller for excessive tape down around the bearing support. If the player operates for a few minutes with tape spilling out the tape may wind around the pinch roller and capstan drive shaft. Usually, if enough tape spills out, it's difficult to remove the ejected cassette.

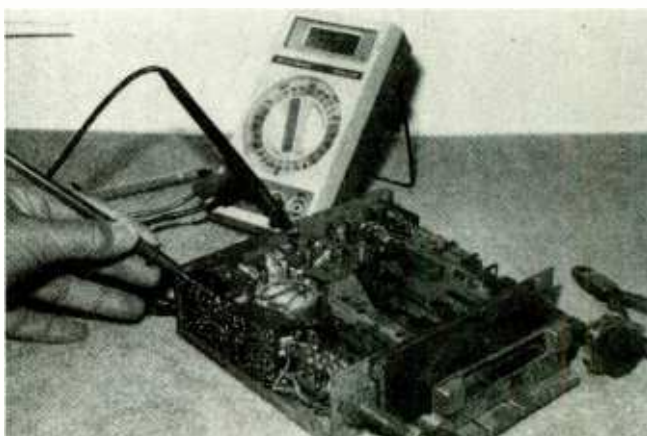

Critical voltage and resistance measurements on transistor and IC components may indicate a leaky or open component.

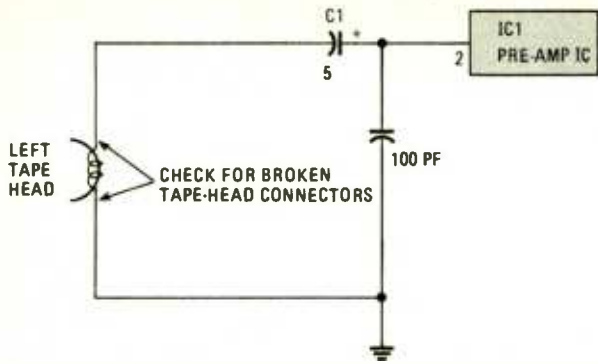

Fig. 3—Intermittent music may result from broken tape-head wires. You may find individual small wires or two cables connected to the tape head. They fray from head movement.

Sometimes the take-up reel will stop for a moment and start up again spilling out tape. Check the take-up reel drive pulley and belt. Replace it if loose. Clean up the drive pulley and belt with alcohol. Remove the take-up spindle. Inspect the spindle bearing for gummed up grease or dry areas. A drop of light oil upon the spindle bearing is enough. Clean off capstan drive and all tape guides for excess oxide. Do not overlook a defective cassette as the cause of spilling out tape. Try another one.

Critical Voltage Tests

Accurate voltage and resistance measurements on the motor, transistor and IC components may solve the dead or distorted cassette player. The pocket digital multimeter (DMM) is ideal to measure those low bias voltages. Check the power supply or leaky component when low or no voltage is found on the transistor or IC terminals.

Low voltage on the collector terminal of the transistor may indicate a leaky component. Likewise, low supply voltage found on the supply-voltage terminal of the IC may indicate a leaky IC or poor power source. No bias voltage between base and emitter terminals of the transistor may indicate a defective transistor. No voltage at the emitter terminal with an emitter resistor in the circuit may indicate an open transistor or resistor.

Comparison voltage and resistance measurements in the stereo channels may help to locate the defective component. Just compare the voltage or resistance readings with the

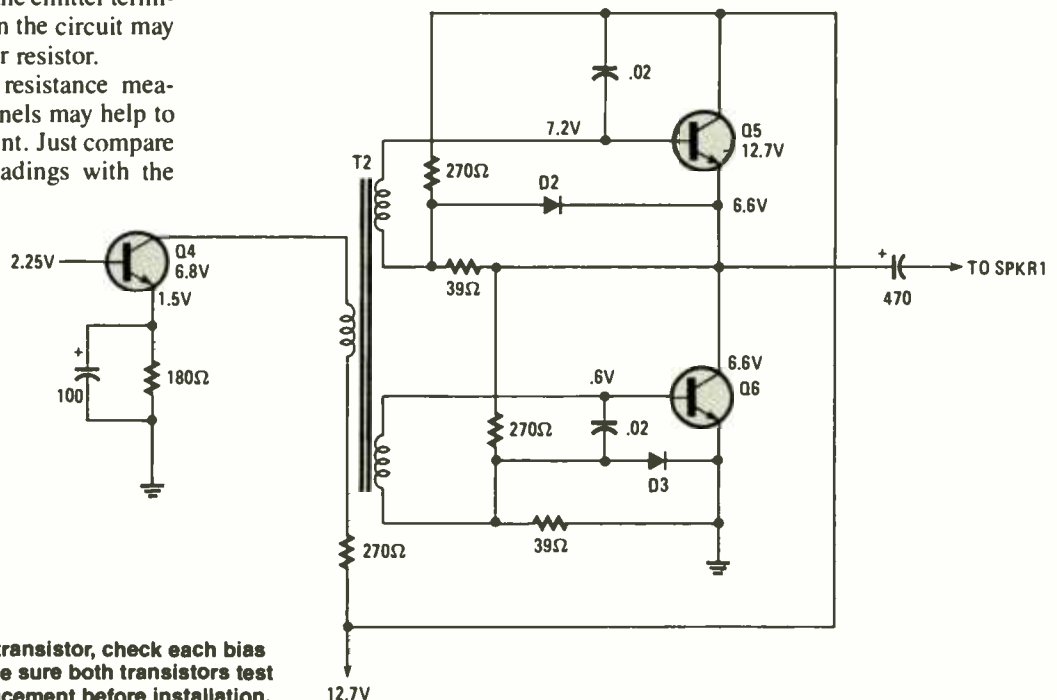

Fig. 4—After locating a leaky transistor, check each bias resistor for correct value. Make sure both transistors test good and check the new replacement before installation.

good channel. Sometimes taking accurate resistance measurements from terminal connections of transistors and IC's to common chassis ground may isolate the defective stage. Critical resistance measurements at output IC terminals may locate a leaky IC or capacitor and a change in resistance of a bias or isolation resistor.

Distorted Right Channel

Since most distorted sound problems are found in the audio output stages, try to locate the suspected output transistors or IC components on the chassis. Often, the audio output transistors have separate heat sinks bolted to the metal chassis. The suspected leaky power IC may be located within one large IC or each separate component. The power IC's are bolted to the chassis or to a large heat sink.

First, take voltage measurements on each transistor terminal. Be sure to write them down on the schematic with a pencil. Determine from the voltage measurements if either transistor is open or leaky. Take in-circuit transistor tests with a transistor tester or a joint-ohm check with the DMM transistor-diode test. Remove the suspected transistor and test it out of the circuit.

Double check all bias resistors while the transistors are out of the circuit. Often, with a leaky output transistor you may find a burned bias resistor (see Fig. 4). Take accurate resistance measurements of each bias diode. A leaky bias diode may produce slight distortion in the audio channels. Do not overlook the open speaker coupling capacitor for dead or really weak audio.

Dead Left Channel

The dead audio channel is easy to locate. If both channels are dead, take a quick voltage check at the power supply and audio output IC. Sometimes one large IC may serve both channels. Check for accurate voltage on each terminal. The low voltage at the supply terminal may indicate a leaky IC. Compare those voltage measurements with the normal stereo channel and schematic.

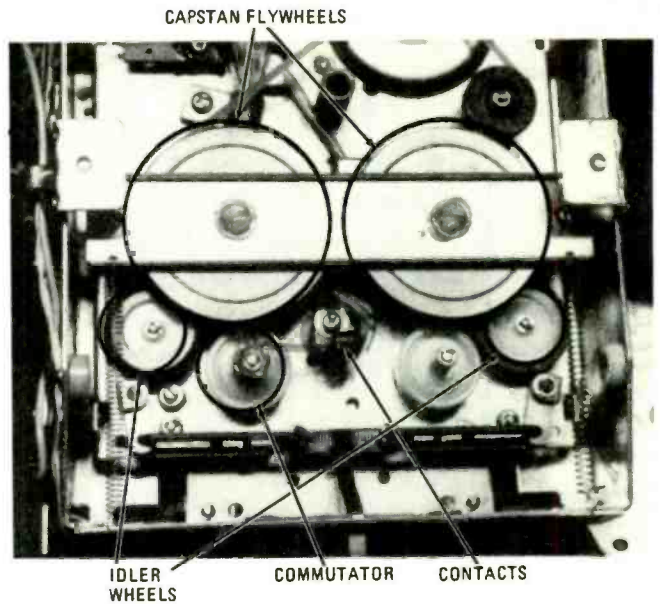
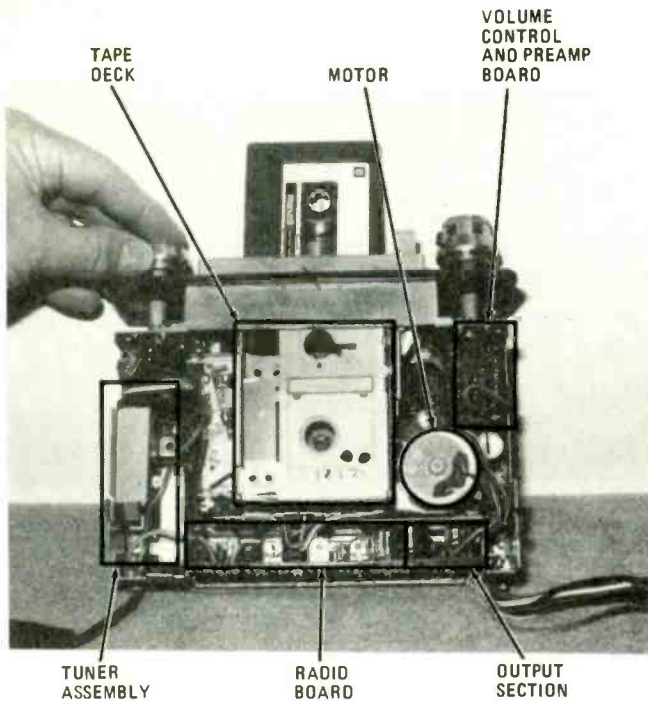

Rapid changes in the direction of the cassette player may be caused by dirty contacts on the prongs and commutator. Clean off both with alcohol and a cleaning stick.

Locate the suspect output transistor or IC components on the PC board or located on metal heat sink.

The separate audio-output IC may have another pre-amp driver IC or all audio circuits are included in one package. Really low voltage at the supply and other terminals may indicate a leaky IC. Suspect a burned resistor or leaky capacitor when voltage is very low on one terminal. You may find very little difference in voltage measurements with a defective IC.

Before replacing the suspected IC, take critical resistance measurements. Measure the resistance from each terminal to common ground. Compare those measurements with the normal audio output IC. Sometimes the meter hand or digital numbers keep moving, which indicates charging or discharging of a capacitor in the circuit. Leave the probe set on the same terminal until it stops. Record the resistance measurement. When the resistance measurement is way off from the good channel, you know either the IC or another component is open or leaky in the audio circuit.

Keep Changing Directions

Suspect a dirty commutator when the cassette player rapidly keeps changing directions. The direction lights will flash off and on. Look for a two or three prong component placed on a rotating commutator, on top or underneath the chassis. The long prongs are coated with silver and eventually become dry. Clean off each prong and rotating commutator with alcohol and cleaning stick. Often that will restore proper operation.

Conclusion

Keeping the auto cassette player in tip-top shape may not be as difficult as you may imagine. Of course, you may not be able to do all the necessary repairs that occur to the cassette player. But, if you can only do the clean up procedure, you have saved a few bucks. Just completing several of the most common repairs makes the day or evening worthwhile. Next time that auto cassette gives up, give it your best shot and you might be able to nurse it back to health. ■

Fig. 5—Here most all the audio-output circuits are found in one IC component. Critical voltage and resistance measurements may locate a leaky or open IC.

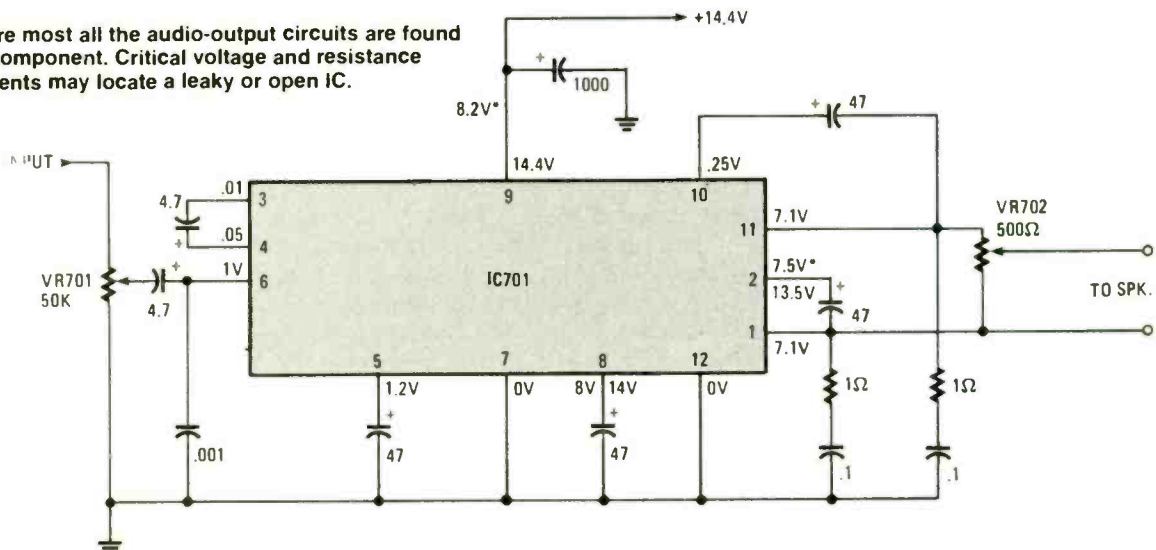

The computer-age will not pass by some senior citizens unnoticed. Read about one who jumped into the middle of the technical revolution

By Rus Morgan

YOU CAN TEACH AN OLD DOG NEW TRICKS IF YOU BUILD on tricks he already knows.

PaPa is eighty two working on one hundred and fifty. Retired from a life-long travail, with the last twenty years operating heavy off-road equipment (a trencher in particular). This no-nonsense octogenarian said of my computer "Who needs it?"

In his sphere, he is right. He is not greatly affected by, nor does he need, the mounds of information modern man injects into his plastic memory banks. I knew it would not be easy bringing Dad into the 21st century electronically, but on his behalf I decided a positive result would be worth any effort—and I had an idea how I was going to bridge the years.

The Plot Begins

He paints houses for extra cash to supplement his two small pensions. He grows green things including most of his own vegetables in his back yard. He keeps in touch with a large number of acquaintances by virtue of a newsletter he publishes each month and mails to each name on his list. Being one of the lucky, durable types, he rarely hurts (at least never admits it), so he never sees a doctor nor a dentist, and only occasionally sees a chiropractor.

He has written his newsletter for many years in a very precise hand and then had a lady friend type it for reproduction. But lately, inexorable but unadmitted arthritis is hampering his penmanship, and I fear he will someday have to forgo the pleasure.

When he announced his bi-yearly visit I determined I would show him the wonders of even hunt-and-peck word processing, and thus keep him involved in his literary friendships for many more years.

Two years previous on his trip I had shown him a Commodore 64 with practically no storage and little use except as a toy. I had set him down at the board thinking it would occupy half a day and he would be enthralled. He had idly poked its keys in his best "examining a dead frog" manner and grunted his opinion.

Settling in

A couple of days after he arrived on this trip I sat him in my favorite chair in front of my nearly new "Leading Edge Model D" determined to 'computerize' him. Shortly before his trip I had gone the whole bit (to coin a pun) and bought a leading edge (IBM compatible) with a 30 Megabyte hard drive, internal modem, color monitor, and a Brother M1509 Printer. I've since acquired some popular programs including dbase 3 Plus, LEWP, Nutshell, PM, a mouse, and Lotus 123. But my favorite friend is Wordstar Professor.

In communicating during my life with my own children and other odd folk not of my predisposition, I have discovered that many times we are all talking about the same things, but speaking a different language. As though a German, a Frenchman, and an Englishman were all jabbering about the opera to each other, each in his own language and none understanding the other.

"Papa," I said with great seriousness. "This is a new kind of ditch digger."

The Analogy

He wasn't fooled and he wasn't comfortable. I had gently insisted he look at my new toy and he was fidgeting. "No it isn't. It's a computer. I saw that little one last time when I was here."

I was encouraged. He hadn't scoffed nor offered to get out of the chair. He even leaned forward for a moment to watch the funny squiggles float down the screen.

I forgot to mention; when his eyes began to fail at seventy-five he stopped off at the drugstore for a pair of 'reading glasses' thereby not admitting (by going to the Optometrist) that his eyes were responding to normal aging. The glasses he was wearing were the \$2.98 variety, thick as the bottom of a coke bottle, and about as useful.

I plugged on, eager to see if my idea would work. "If you were to go back to construction tomorrow and needed a new trencher and the salesman said the machine in front of you was a state-of-the-art trencher, but it would also dig, scrape, lift, load, spread and pack, would you buy it?"

"Depends on the price and guarantee," he said, tacitly agreeing that if anybody could operate such a machine, he could.

So far, so good. "Okay, let's say price and guarantee were acceptable. Would you try it out?"

"Probably," came the grudging reply. He was sure I had a point to make, but not sure he wanted to hear it.

"Well, Papa, what you see in front of you is a state-of-the-art typewriter, no more, no less. You tell it what to do through keys instead of the levers like your trencher and it stores book fulls of information. It spells correctly, it calculates, and it will arrange that information any way you want it. It will even keep track of your painting jobs—your newsletter friends—and write and store your newsletter."

My canny senior was not about to be overwhelmed. "What do I have to do?"

"You have to know the alphabet."

The hook sunk deeper. He turned and speared me with myopic blue eyes. "Is that all there is to a computer?"

(Continued on page 96)



ZEBRA SYSTEMS CAR SIGN DESIGNER KIT

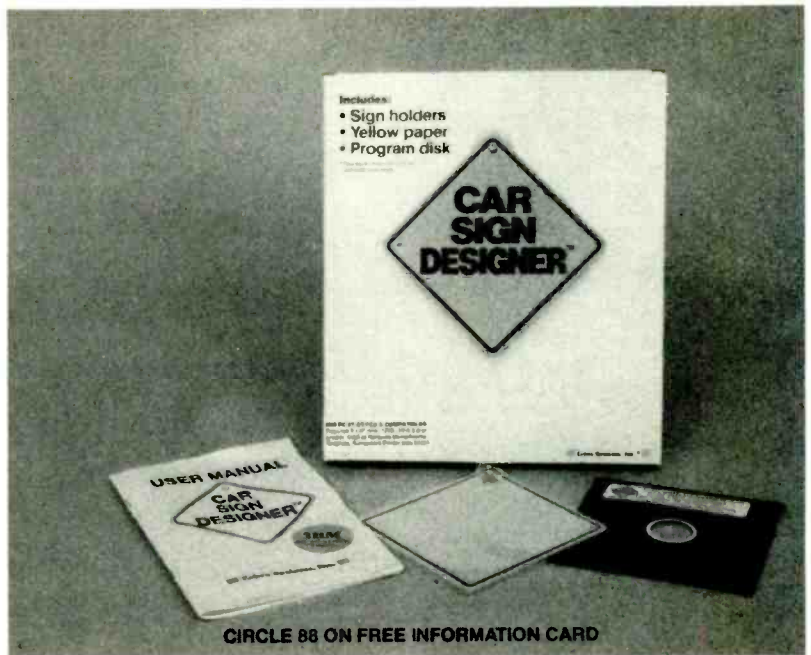

Now you can create those humorous yellow diamond signs for the back of your car

□ OF COURSE YOU'VE SEEN ALL OF THE yellow-diamond car-sign messages in the rear windows of cars. There's the original, "Baby on Board," and the many other humorous variations such as "Mother-in-law in Trunk," "Bachelor Aboard," "Don't Laugh, It's Paid For," and "Blow Horn, I'm Napping." Maybe you've even thought up a few that are more original, or funnier; I know that I have.

Now you can write your own messages and print them out on stiff yellow paper on your dot-matrix printer, with help from the Zebra Systems Car Designer Kit. After receiving the program via mail order, I read the manual and was up and running within 10 minutes. The first sign I made appears on this page: Not bad for a beginner!

The Run-down

Included with the sign-maker kit are the program diskette; 50 sheets of special, stiff, yellow, car-sign paper; two reusable sign-holders with clear plastic suction cups; owner registration form (be sure to fill it out); and an order form for more supplies.

If, like me, you own a PC or compatible, you'll need DOS Version 2.0, or later, at least 128K of RAM, a CGA or Hercules monochrome-graphics adapter, one or more 5-1/4-inch disk drives, and a compatible graphics printer. My computer has a built-in 20-

megabyte hard-disk drive that made running the program even simpler. The software is also available in Apple II (64K), II+, IIe and IIc; Tandy Color Computer (64K); and Commodore 64/64C/128 formats.

The details of running the Car Sign Designer program on either the floppy drive(s) or hard disk is covered in the manual, and it is what you have been normally doing with your computer for other programs. Note, however, that PC-format disks come configured for CGA graphics and an Epson RX/FX/EX/LX compatible printer. If your system differs, then you must run the package's installation (INSTALL) program.



Here's Hands-on Electronics car sign in a plastic holder and ready for installation on the inside surface of the family wheels. A bit of moisture on the plastic suction cup has a lasting effect.

There are three inputs that you must provide for the INSTALL program. First you must indicate the graphics adapter you use: IBM Color/Graphics Adapter, IBM Enhanced Graphics Adapter, IBM PCjr, or Hercules graphics card. Then you have to tell the program what printer you are using. A list of 13 printer groups are listed. My IBM Graphics printer was not listed so I decided to pick any one of the 13 groups and see if it would work with my system. Sure enough, I selected the IBM ProPrinter and the printout was correct. The final question asked in the installation process is, "Will your printer require line feeds?" If you don't know, take a guess; the first printout will tell you how good a guesser you are.

The Dry Run

The Car Sign Designer program finds all its subprograms within the default directory. To run the program just type: CSD and then (RETURN). After a few seconds you will see the Car Sign Designer screen with its familiar diamond. That is called the *editing screen*. All the controls that you need to generate a sign are given at the right, except one. To exit the program you must type (CTRL) X.

Before you shoot ahead, press (CTRL) D and a short demonstration program will run. That quick demo will show you samples of one-, two-, three-,

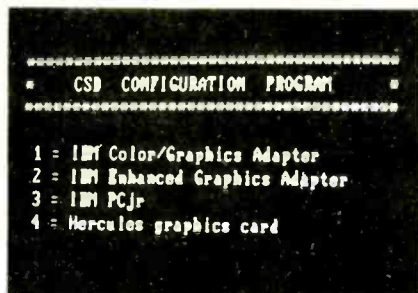

During the configuration procedure for the Car Sign Designer program, the user is asked to indicate the type of graphics adapter available in his (or her) computer.

and four-line signs, as well as all the characters in the Car Sign Designer program's character set. The few minutes that it takes to run the program will upgrade your status as a user to *almost* expert!

Getting to Work

OK, let's make a sign. Do not use the yellow paper supplied in the kit. Ordinary printer paper will do the job during practice- and design-sessions. You should have the Car Sign Designer editing screen up. Press (CTRL) C to clear the text from the diamond sign area. Then repeatedly press (CTRL) L until the *dancing* vertical-line cursor indicates two lines of text available.

Now type the message slowly. Strike the next key only after the previously selected letter has been printed. Type HANDS-ON on the first line, then strike the down arrow on your numeric pad. The cursor jumps to the second (lower)

line. The printed line fills out the available width and centers itself. Then type the next line: ELECTRONICS. You should get the results as shown in the photo. If you like the results (we did), hit (CTRL) P and the printer will output the sign, full size.

There, you are now an expert Car Sign Designer. If you used the *incorrect* printer designation and line-feed information during the program installation, the printer will fail to produce what is seen on the editing screen. Try again. If after several trials you fail to get a suitable printout, contact Zebra Systems and describe to them the computer-system setup you are using. They will do their best to get you up and running.

Take some time out to use the controls itemized on the editing screen. Also, become familiar with the layout techniques discussed in the manual. The character set is complete with all the punctuation symbols, plus three symbols: For a heart press (UP ARROW); happy face, press (}) (right bracket); and musical notes, press (@) (at sign).

Make a Car Sign

Design the car sign you want and load the yellow fan-fold paper. Follow the instructions in the manual, or load the yellow paper in the same position as the white paper you used for practice. It is important that the diamond design (actually a 5-inch square standing on one edge) is centered on the paper. The menu bar at the bottom of the screen will ask you how many copies you want.

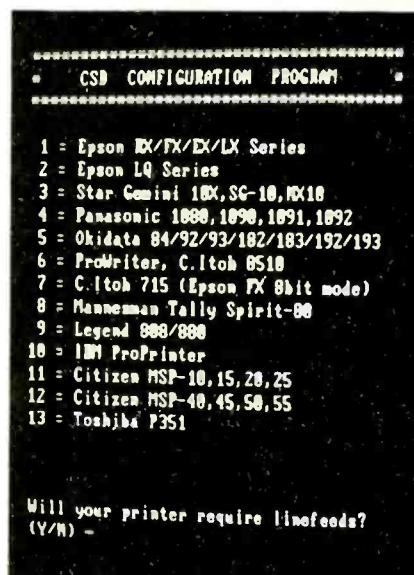

The second configuration decision that has to be made by the user is to indicate which printer type is installed in the system. The user also gives line-feed info.

Type 1 and then hit (RETURN). You can make multiple copies later when you are sure that the valuable yellow paper will not be wasted.

The manual instructs how to prepare the sign for the clear-plastic sign holder, but that is simple enough. Two sign holders and two plastic suction cups are supplied with the kit. The rest is a snap.

A note on safety: Should you place the car sign on the rear window, make sure that it does not obscure your view. The best position is the left-most side behind the driver. If your car has a tiny rear window, do not obscure the driver's view with a car sign. A rear left-side window is almost never used by the driver.

Final Printout

Should you want a Car Sign Designer kit, write to Zebra Systems, Inc., 76-06 Jamaica Avenue, Woodhaven, New York 11421 (telephone 718/296-2385) to place your order. Specify the computer system, you are using and the printer name and model number. The kit of one program diskette, manual, 50 sheets of yellow paper and two plastic sign holders sells for \$29.95 plus \$3.00 for shipping and handling costs. A box of six additional plastic sign holders with suction cups sells for \$9.95. A box of 200 sheets of yellow paper sells for \$14.95. Zebra Systems accepts MasterCard and VISA payment. For more information circle No. 88 on the Free Information Card.

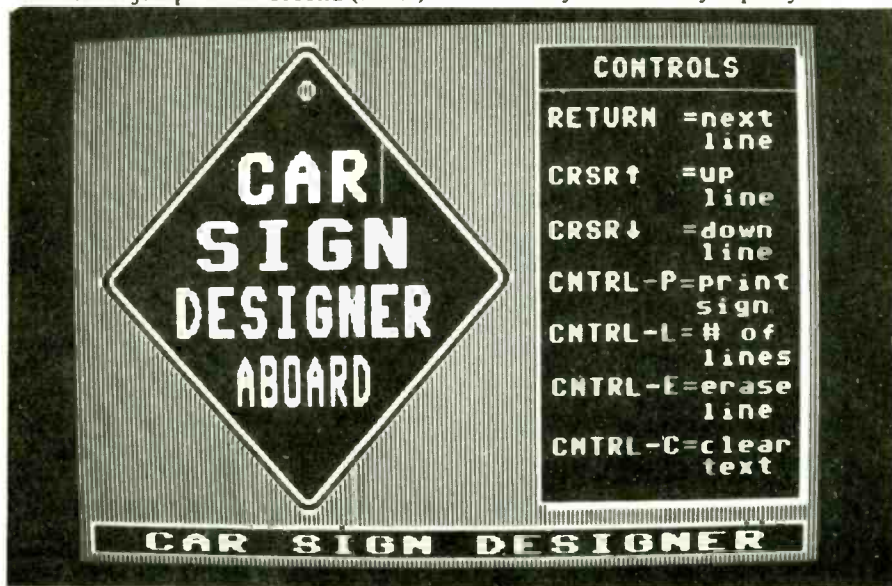

Here is a photo that shows the monitor screen's display prior to preparing your first car sign. Notice how the letters are compressed on the very bottom line. Should you want equal-width letters throughout, add spaces at either end of the line for those lines that are overextended. Note the list of controls at the right. Press (CTRL) C and the diamond-shaped area will clear itself, leaving only the thin vertical position line

GIZMO

SEPTEMBER 1988

GIZMOLOGY FOR THE FUN OF IT

VOLUME 1, NUMBER 7

AVD Remote-Activated VCR Programmer pg. 1
 Casio Desk-Top Calculator pg. 2
 Viral Response System's Viralizer pg. 3
 Ricoh XR-M SLR Camera pg. 4
 Realistic Universal Remote Control pg. 5

GIZMO/BYTES

Fax/Telephone Switch pg. 6
 Moisture-Proof Mini Speakers pg. 6
 Factory F2 Knife pg. 7
 Illuminated Umbrella pg. 7
 Shintom VCR pg. 7
 Solar Garden Sprayer pg. 7
 Super Blocks Telephone pg. 7
 Canon Plain Paper Electronic Whiteboard pg. 8
 Prism Television pg. 8
 Sony Extended-Definition Beta VCR pg. 8
 TeleQuest NotePad Plus Telephone pg. 8
 Braun Oral Care Center pg. 9
 Personal Protection Catalog pg. 9
 Plantronics Headset pg. 9
 Sharp Cassette Player pg. 9
 Sony Talking Clock Radio pg. 9
 Bose Speaker System pg. 10
 Camcorder Carryall pg. 10
 Dirt Alert Video Head Cleaner pg. 10
 Gemini Microwave Oven pg. 10
 Sharp Video Brochure pg. 10
 Executive Communications Systems Super Directory pg. 11
 Light Weight Digital Stopwatch pg. 11
 Precor Low Impact Climber pg. 11
 Pioneer Car Stereo Head Unit pg. 11
 Yorx Twin Handset Telephone pg. 11

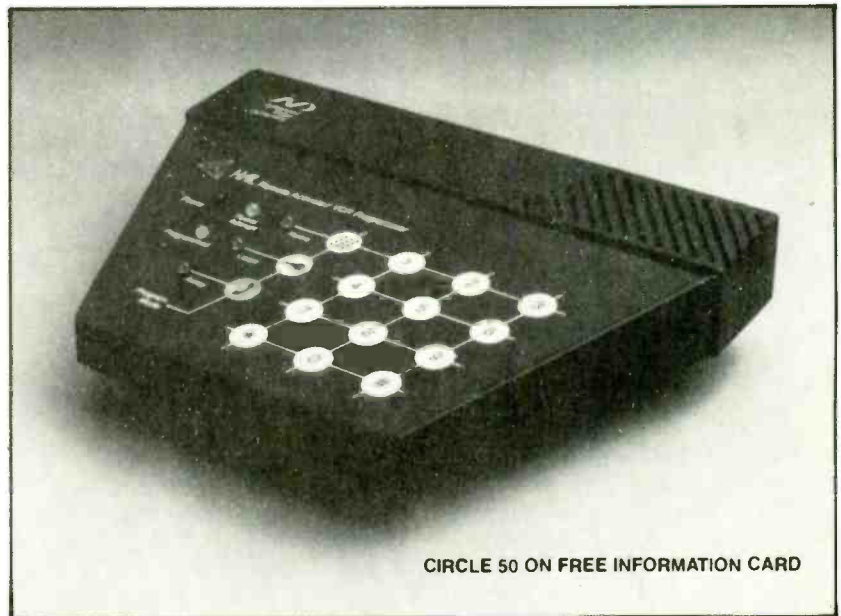

CIRCLE 50 ON FREE INFORMATION CARD

HAL No

HAL REMOTE-ACTIVATED VCR PROGRAMMER. Manufactured by: **Advanced Video Dynamics, Inc., 705 General Washington Ave., Norristown, PA 19403. Price: \$189.95.**

We know they're out there: Home video enthusiasts who's lives have become an endless round of program-taping and cassette-duplicating schedules; who's homes are filling up with cassettes they've carefully labeled and classified, but which they never get around to looking at. They are too busy adding to their open-ended video library.

It can be a lonely life for a home-video obsessive. There are always timers to be set, cassettes to be rewind, filing and labeling to be done, and blank-cassette purchases to be made: it's easy to see how the video lifestyle can really cut into a victim's social life. But *Advanced Video Dynamics, Inc.* has come up with a remote-activated VCR programmer, called *HAL*, that's designed to attack the problem on a couple of different fronts.

With your pal, *HAL*, you'll be able to activate functions of your random-access remote-controlled VCR that might other-

wise demand your presence at home. Like a physician summoned via a beeper to the telephone at parties and social functions, you can call *HAL* at home and tell him to record that "lost episode" of *Highway Patrol*, or the cavalcade of beautiful people appearing on the *Celebrity Dumb-Pet Tricks* special.

Even if you're home alone, you'll still have someone to talk to: *HAL* is among the most chatty appliances we've ever used. In fact, a sheet included with the unit's instructions warns that *HAL* "answers the phone frequently while [the user] is at home," indicating that the unit is eager to shoot the breeze with just about anyone.

In fact, our test indicated that *HAL* has a mind of its own. Although willing to converse and carry out the "learn mode," cheerily telling us, "learning continues" or, much less frequently, "learning OK," *HAL* balked when it came to committing its lessons to memory. In theory, *HAL* is an elegant adjunct to home video, but in practice, the little guy turned out to be just a brat.

HAL combines elements of a universal remote control with answering-machine technology to provide telephone control of functions that are conventionally carried out by unit-specific infrared remote-con-

trols. Although a VCR and cable-TV remote accessory, the unit could theoretically learn commands for CD players, etc. As a bonus for the electronically phobic, HAL can chat with the user through VCR-programming sequences, sort of like those scenes in flying movies where the control tower talks an inexperienced pilot through a landing. HAL obviously aims to please.

The compact device plugs into a wall outlet and the telephone line, and learns the commands of a random-access remote via an "infrared TX/RX window" like the one found on standard universal remote-controls. HAL is unable to learn commands from a non-random-access VCR. If your unit is equipped with the wrong kind of remote control, the directions suggest purchasing a tuner to serve as a translator between HAL and your VCR.

In the brave words of the owner's manual, "the programming process sounds a great deal more complicated than it actually is." In the learning mode, the control panel's "power-failure indicator light" will begin flashing. Remote-control buttons shouldn't be pressed before it does. Pressing the "learn" button, marked with a key symbol and a green signal lamp, is HAL's signal to introduce himself ("Hello, I am HAL"), give the time, and ask the user to begin entering commands from a VCR or cable remote-controller.

There's more, but it comes down to holding the business end of a remote controller to HAL's infrared window and punching various choices out on the control pad while HAL chatters away, thank-

ing the user for the choices made and confirming them in a squawky, mechanical (but always polite) voice. "Learning okay" was the hardest sentence to coax out of the box. That means a command has been successfully learned and the user can go on to the next one. "Learning continues" means the command must be re-entered. The instructions gently caution, "HAL may require several tries before learning a command pattern from your remote controller," which, judging from our experience, ranks as one of the grandest understatements in the history of electronics-instruction literature.

Programming the unit's timer and inputting a "security code" were quick and easy procedures. And we managed to teach HAL the commands of a Sony RMT-148 Betamax controller. But the little guy refused the commands of a Jerrold 450 cable-box controller, a Sony RMT-125 video remote (also capable of controlling the RMT-148's machine, and vice versa), a JVC VHS remote controller (RG/AA/UM3), and an NEC Betamax controller (RB-70E).

A call to AVD brought some specific refinements to the instructions. We'd already installed fresh batteries in the remotes that we were attempting to "teach" to HAL. There were other suggestions, regarding positioning the two infrared panels, but none turned the trick.

Our trouble in getting HAL to learn, meant we never got beyond "programming" to the pleasures and conveniences of the "home" and "away" modes. A touch of the "HOME" mode button

prompts HAL to ask the user to either "set program," "review program," "set clock," or "exit." If you decide to "set program" or "review program," the unit talks you through sometimes complex sequences most VCRs, and VCR owners, would rather not talk about.

In the exciting "away" mode, HAL promises to keep the user in touch with the home-video system from any touch-dial phone in the world. Imagine recording *Gilligan's Island* with a phone call from Tahiti. In both "home" and "away" modes, there's a "step-saver" programming sequence that cuts the small talk and gets right down to the recording business.

In fairness to what could be a nifty VCR adjunct, the instructions include a warning against "fluorescent lamps," but only in terms of keeping the unit "away" from them. The same caution applies to televisions and electric motors. The relatively small room in which programming failed, is illuminated by overhead fluorescent tubes. But that's real life, which is about the only special claim that GIZMO's tests make.

We certainly like the idea of HAL, and if there's the slightest chance that this was a defective test model, we'd be happy to talk to HAL again over a blinking remote-control unit. But as it was, HAL didn't see eye-to-eye with us, or at least not with the various infrared remotes we wielded in our attempts to hear "learning okay" from Advanced Video Dynamics promising remote-activated VCR programmer. Less talk and more action is what we needed from HAL. ■

The Color of Money

CASIO DESK-TOP CALCULATOR (JE-3). Manufactured by: Casio, Inc. 570 Mt. Pleasant Ave., P.O. Box 7000, Dover, NJ 07801. Price: \$29.95.

Despite the best efforts of Madison Avenue, product-publicity managers, and the consumer-electronics industry in general, for a lot of people the logic of "this year's model" is none too compelling. Instead, "if it's not broke, don't fix it" is the catch phrase for many who hang onto electronic tools for years after they've been declared obsolete by the marketplace.

When GIZMO decided to look at a current *Casio Desk-Top Calculator*, the JE-3, we knew exactly who should test the unit.

Our candidate to try out the model has used his present personal calculator, a palm-sized Casio unit, for six or seven years. Not only would a few sessions with the JE-3 bring him into the consumer-elec-



CIRCLE 51 ON FREE INFORMATION CARD

tronics present, but we asked him to put the unit through its paces with the most tension-filled of consumer-calculator exercises: computation of the yearly Federal Income Tax—a torture test for the user if not for the machine.

His reaction when we told him the JE-3 is a desk-top model indicated just how little attention he pays to current consumer electronics. For him, the term "desk-top" conjured up the image of a machine about the size of a shoebox, with a long curved handle on its right side. In reality, the petite JE-3 is a mere 1.5-inches tall at the display end, with a keypad 4-inches wide and 3.75-inches long. It is a smart update of calculator design, with a big, flat keyboard and a 12-digit green display of outstanding brightness. With its two "AA" batteries in place, the calculator weighs a mere 5.6 ounces.

Especially intriguing is Casio's claim that the unit's "electroluminescent backlight . . . permits viewing even in total darkness." Our tester figured that's where a lot of consumers find themselves come tax time.

A square-root function is probably the most exotic of the unit's mathematical capabilities. There's also a memory feature, a trio of methods for rounding-off sums, an "overflow" feature (when results exceed 12 digits, the display shows the letter "E," indicates the position of the decimal point and freezes the figures until "over-

flow" is turned off), and sophisticated percentage capabilities for figuring mark-up, percent of increase, etc.

In our test of the JE-3, the rounding-off functions were slightly confusing. Controlled with a key designated "RND," the feature offers options labeled "F," "5/4" and "CUT." All seemed slightly different from the standard commercial arithmetic rounding-off method.

According to the JE-3 instructions, "F" allows the decimal point to float while the "underflow system works to protect the significant digits." Using the "5/4" setting, the calculator rounds off at two decimal places, "supplying floating modes for entry and intermediate result." In explaining "CUT," words apparently failed *Casio*. "The answer is cut off in a similar way to the above," is the instruction's not very illuminating description.

The JE-3 display, described in the specifications chart as "transmissive liquid crystal," is exceedingly easy-to-read under most circumstances. Once the user selects a process, its symbol is displayed to the left of the back-lit numerals, with commas above the numbers and the decimal point in its usual bottom location. Our tester wasn't fond of the hanging commas, although admitting the JE-3's designers probably had a rational reason for the unusual placement.

What he wasn't as tolerant of is how close together the digits appear on the

LCD. A long session in front of the JE-3 and the eyes may refuse to focus on the closely packed numbers. He also would have preferred a somewhat firmer keypad touch. The soft-touch keypad, he maintained, made it easy to inadvertently enter a digit.

Under some lighting conditions, it's necessary to angle or tilt the display panel to read it. Probably the result of backlighting, it's a limitation easily avoided. Our tester did take the JE-3 into a dark closet and reported that, in fact, the LCD could be easily read.

The JE-3's diminutive size was not our tester's favorite feature. Too big for the hand, this desk-top model is small enough to disappear under ledger sheets and financial forms on a cluttered surface.

Generally, however, using the Casio Desk-Top Calculator convinced him that there have been enormous strides in calculator designs since his antique Casio (an HL-807) rolled off the assembly line. Not, however, that he intends to replace it.

He was also grateful that none of the contemporary calculator's functions were signaled audibly. At tax time, enough transpires without an electronic soundtrack of weeps and beeps. Although he's keeping his trusty palm-sized model, our tester did insist that if the IRS ever requires square-root calculations, the Casio JE-3 is the calculator he intends to have on his desk. ■

Cold-War Cure

VIRALIZER WITH VIRA-SPRAY I, II.
Manufactured by: **Viral Response Systems, Inc., 34 E. Putman Ave., Greenwich, CT 06830. Price: \$34.95.**

Despite the non-stop miracles of modern medicine, the "common cold" continues to elude a cure. A common affliction and a major annoyance, it has attracted the interest and energy of countless investigators and inspired treatments ranging from the ethnic, like chicken soup, to the scientific, such as anti-histamines and antibiotics. Last year, a billion consumer dollars were spent on cold remedies.

Now a new weapon in the war against colds has entered the fray. *Viral Response System's* *Viralizer* looks and sounds suspiciously like a hairdryer, but its manufacturer claims it as a significant breakthrough in home treatment of colds, sinus infections, and allergy symptoms. Similar to a considerably more expensive device, called the "Rhinotherm," invented at Israel's Weizmann Institute, this "heated nebulizer-sprayer" uses a clinical discovery as the basis of its approach to treating the common cold and related ailments.

CIRCLE 52 ON FREE INFORMATION CARD

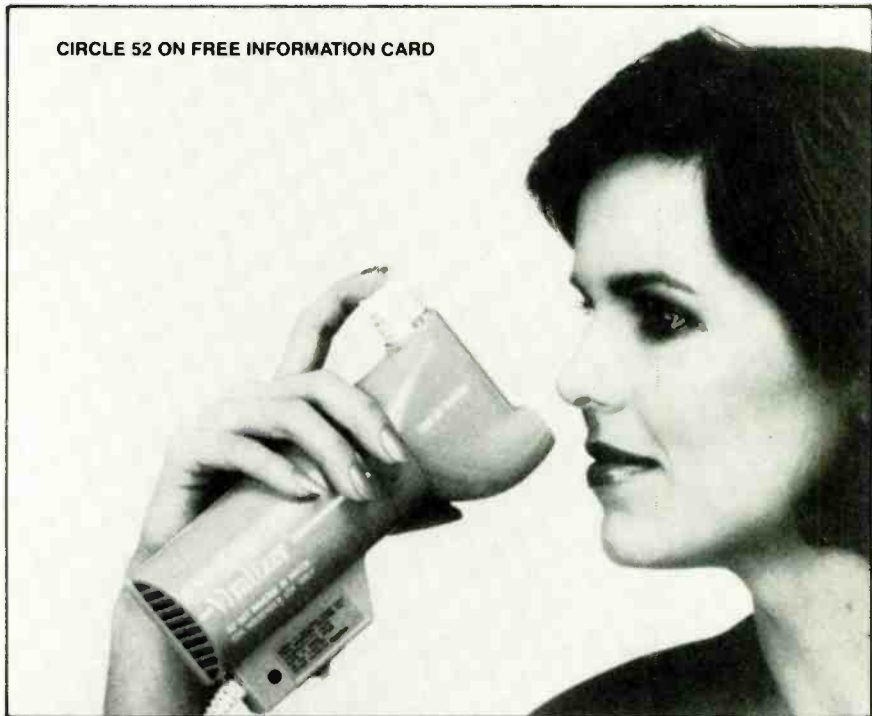

The primary cold-causing virus, the rhinovirus, according to that discovery, cannot live in temperatures exceeding 120°F. By directing a stream of heated air into the

relatively cooler nasal passages and throat, the *Viralizer's* action is said to kill the virus.

Our test unit came in two parts, the

larger section is very similar to (if not actually) a cylindrical hairdryer fitted with a heating element rated at 130 watts, instead of the usual 1200. A two-speed sliding switch ("hi," "lo," "off") and the device's AC-power cord complete the main unit. The smaller section features a nozzle that directs the hot-air stream and a pump compartment that holds one of two small *Vira-Spray* bottles, containing either an analgesic bactericide or a decongestant.

Assembly is easy, the user merely lines up the white arrow on one section with the white dot on the other, and twists. Turning the assembled unit upside down, removing the cap from one of the bottles, and snapping it on to the pump stem, installs the *Vira-Spray*. The *Viralizer* is now ready for you to use.

Plug it in, select a heat setting ("lo" is recommended for children), hold the unit two inches under the nose, breathe normally, and allow the heated air to enter the nose or throat for two to three minutes. Pushing down on the *Vira-Spray* bottle once each minute releases the medicated spray. As the instructions suggest, in bold type, keep your eyes closed while spraying. Treatment should be repeated every two or three hours as needed for one or two days. Simple instructions explain this uncomplicated device.

Since we were the victim of that very "common cold" during our tests, feverish flights of miracle-cure fancy gripped us as we unpacked and assembled the product. Instant relief proved not to be the case. Repeated use over a week's time left us uncertain whether the cold's symptoms disappeared because of the *Viralizer*, or due to our body's own defenses. It did,

however, help reduce some of the running nose misery that so often accompanies that malady.

Though the device is simple to use and the principles by which it operates are easy to grasp, in practice, the *Viralizer* exhibited some glitches. Holding the unit as pictured in the instructions while using it at the "hi" heat-setting meant the tips of the fingers rapidly reached a rather uncomfortable temperature. That problem was easily solved by grasping the *Viralizer* at a distance from the location of the unit's heating element. Also at the "hi" heat-setting, holding the unit's nozzle as instructed (two inches from the nose) successfully dried out the interior, but made us feel we might be cooking the exterior. Using it at a greater distance, say six to eight inches, no doubt lessened the unit's efficacy, and unfortunately meant the liquid spray had a tendency to cover the user's entire face. Using the "lo" heat setting avoided those problems, but also seemed to reduce the device's effectiveness.

Did using the *Viralizer* "cure" our cold? Or, for that matter, were the manufacturer's bactericide and decongestant any more efficiently dispensed via this unit? To the first question, a definite maybe; as for the second, we really wonder if those common non-prescription medicines aren't for the most part cosmetic and marketing aids. People have been spraying nostrils into their mouths and nose's to treat colds for centuries, seldom gaining more than symptomatic relief. But we have some doubts as to the device's ability to sufficiently heat nasal passages to a temperature that would be high enough to knock out the viruses.

We should mention that at one point our

test unit was pressed into emergency service, performing the duties of its hairdryer cousin. It served well enough, though not with the speed normally desired. Regardless of its therapeutic value, it remains a functional home appliance. Like the old *Saturday Night Live* joke regarding two products in one; "a dessert topping and a floor wax."

In one area of effectiveness—namely marketing—we have no doubts regarding the *Viralizer*'s performance. Our test unit came with a thick packet of clinical studies claiming up to 97% effectiveness in eliminating cold symptoms without the use of systemic medication. An impressive advertising and public-relations campaign associated the *Viralizer* with the widely reported effects of high temperatures on the cold-causing rhinovirus subtypes. However, those are marketing, and not therapeutic triumphs. Information supplied with the unit included a long list of testimonials from satisfied participants in studies of the *Viralizer*'s use.

We are not, of course, health-care professionals so we can't judge the validity of those claims and testimonials. But given our own experience with this home treatment, it would seem hope for immediate relief from the drip-drip-drip of the common cold might have something to do with the outstanding success rate and the perception of a "cure" on the part of participants in those clinical tests. We would be reluctant to vouch for this product's efficacy in all cases. Still, in man's endless "cold" war, the choice of weapons is best left up to the individual soldier. Some cold sufferers will undoubtedly swear by the *Viralizer*, while others, disappointed by the lack of a "cure," will swear at it. ■

Programmed Image

RICOH XR-M MULTI-PROGRAM TRI-METERING SYSTEM SLR CAMERA. RIKENON P ZOOM LENS (35-70/3.4-4.5). Manufactured by: Ricoh Corp., 5 Dedrick Pl., West Caldwell, NJ 07006. Price: \$509.

Over the past 20 years, the camera industry has developed products within three major categories: manual, auto-focus, and programmable. Manual cameras require the user to set all adjustments on the camera—shutter speed, aperture, and focus, and to manually advance the film after each shot, and then rewind by hand after shooting a roll. Those traditionally are the camera of choice for "real" photographers.

Auto-focus cameras were initially of the family-vacation variety, delivering unpre-



**CIRCLE 53 ON
FREE INFORMATION CARD**

dictable results both outside in bright sun or indoors with a flash—the *Brownie* series from Kodak is undoubtedly the most famous example. That product category has since become ultra-sophisticated, at least in some price categories.

Programmable cameras are a relatively recent development, allowing the photographer some flexibility in terms of what's going on behind the lens. For example, programmable units allow shutter speed, aperture, or both to be set man-

ually, or, in the program mode, all settings can be manipulated automatically. Advancing and rewinding can be automatic or not, depending on the manufacturer and the camera model.

Those programmable cameras were a market breakthrough, allowing manufacturers to cater to consumers previously untapped, namely the amateur with a hankering to learn and be photographically creative. Before, users were limited to either manuals (which required a sometimes daunting degree of technical skill) or point-and-shoots (which produced unpredictable results).

Both programmable and auto-focus technologies have come a long way since their introductions. Just how far is shown in a new programmable camera from Ricoh, the XR-M. That state-of-the-art camera features computer read-outs, and requires the power of no less than four "AA" batteries for operation.

The unit we tested came equipped with a Rikenon P 200 (35-70/3.4-4.5) Macro Lens. That allows some zooming capability and, taking advantage of the camera's built-in film advance, is capable of continuous shooting at three frames per second; a real bonus if you do any amount of action photography. Unfortunately, our test unit was not supplied with a flash attachment, which was a real disadvantage in putting the camera through its paces. We were forced either to shoot with high-speed film or concentrate on outdoor shots. We opted for the latter.

Frankly, we were a bit overwhelmed by the XR-M. We think that a little more time with that rather complicated programmable would have better served both the photographer and the camera. The upside of its complications is its impressive array of features and options, some of which we were unable to use.

The top of the camera includes the LCD control panel, providing the user with basic operational information: Program mode in operation, including "PA," program action for moving subjects or use with telephoto lenses; "P," program normal for average illumination; or "PD," program depth for achieving greater depth-of-field. The control panel also indicates battery status, continuous/single-frame shooting, film ISO, and exposures made and remaining.

There is an information screen within the viewfinder as well, which shows aperture setting, shutter speed, etc. In total, the viewfinder screen provides 18 bits of picture-taking information. It seems to us that by the time the user sees and digests the information, the photo opportunity will be long gone—state-of-the-art has costs as well as rewards. We just wish someone in the camera industry would recall the old adage, "less is more."

Having said that, we should report that the Ricoh's performance was first-rate during our somewhat abbreviated test, and we tried as many of the options as time would allow. Among our favorite functions was one we hadn't encountered before called "program depth-of-field preview."

That allows the photographer to press a button and see the background and foreground as they will appear in the final photo. If the user is undecided as to whether background focus is important for a particular shot, it can be previewed either in or out of focus. Greater depth of field—achieved with a higher *f*-stop setting—means both main subject and background are in focus. With a lower *f*-stop, only the main subject is in sharp focus, while the background is blurred.

Another feature we got to know was "AE lock," automatic exposure lock, which allows the user to set an exposure, press a button, and lock that exposure in the camera's memory. Then, further exposures in the same lighting situation can be composed with the photographer's full attention on the shot itself, instead of resetting before each new picture in the same location.

In addition to those two capabilities, the XR-M has the usual quota of programmable features: Aperture priority (another depth-of-field function); automatic backlight control (a metering system allowing the camera to automatically adjust to difficult lighting situations), and spot metering (which allows the user to decide on the most-important area of the photo and which reads the light in the selected area only). The subject, however, should be centered in the viewfinder.

Another aspect of the XR-M worth mentioning is its owner's manual—in our experience, an especially important accessory in photography. This example is clear, concise, and very-much user-friendly. It's well thought out with drawings and diagrams accompanying the text, and sample photos where applicable. Some sections may require a close reading, or even a couple of readings, if only because of the amount of rather-complex information supplied.

Certainly the XR-M is one of the best programmable SLR cameras we've come across. It offers the serious (amateur or professional) photographer maximum control in a variety of picture-taking situations. The chance to be creative isn't stymied, but enhanced by the camera's options. Before using that programmable, however, we'd not thought of photography as such a sensory experience. We could have done without some of the flashing, buzzing, beeping, dials, and displays, but apparently programmable excellence, at least for Ricoh's design department, demands its trumpets and flourishes. ■



One for All

REALISTIC UNIVERSAL REMOTE CONTROL (15-1901). Manufactured by: Radio Shack Division, Tandy Corp., One Tandy Center, Fort Worth, TX 76102. Price: \$99.95.

Universal remotes—those programmable, all-for-one and one-for-all controls that replace a whole coffee table full of unit-specific remotes—work on a principle opposite that of divide and conquer. By sweeping a whole gaggle of button-heavy modules under the rug and zapping their capabilities into one super-wand, the universal remote earns the respect of the gadget aficionado, and the gratitude of whomever dusts the room.

The assumption is, of course, that the household has a whole raft of remotes to do away with and—since a remote without a target is like a moon without a planet—a whole array of televisions, VCRs, cable controls, CD players, and maybe a satellite-TV channel-selector/dish-positioner thrown in for good measure. Given con-

Gizmo/Bytes

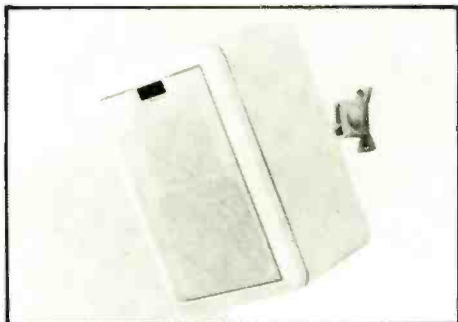

Fax/Telephone Automatic Switch



Moisture-Proof Mini Speaker

Moisture-Proof Mini Speakers

Having introduced a weatherproof *Mini Speaker (model 55)* in black matte, *Altec Lansing* (Consumer Products, Milford, PA 18337) has made the popular unit available in white. The loudspeaker's small size and versatility of mounting make it ideal for use in back yards, around a pool, the patio, or any place moisture might damage unprotected audio components. Unported, the model 55 is housed in a thick-walled cabinet constructed of high-temperature, glass-filled "ABS" that's further sealed with rubber gaskets. Heavy-duty, spring-loaded input terminals "assure firm contact for wire leads even under adverse climate conditions." Price (per pair): \$250.

CIRCLE 55 ON FREE INFORMATION CARD

Fax/Telephone Automatic Switch

Facsimile transmission is the loud new noise on the electronic-communications front, with thousands of lower-cost units purchased in the past 18 months. So what's the little guy to do without a second telephone line for the home-office fax machine? How about a *Fax/Telephone Automatic Switch*? According to the device's distributor, *Executive Communications Systems* (2622 Quaker Ridge Pl., Ontario, CA 91761), that device will "automatically switch a phone call to the phone line and emit a beeping sound if the incoming call is not fax." Warranted for a year, the switch "does not effect either fax or telephone outdialing." Price: \$64.95.

CIRCLE 56 ON FREE INFORMATION CARD

(Continued from previous page)

sumer spending patterns of recent years, that may not be too far from the mark. Increasingly, control of our electronic-entertainment slaves has passed to peripherals; ultrasonic and infrared overseers that at first seemed toys for the lazy, but that today are deemed near indispensable.

Realistic's entry into the field is a well-considered gizmo with a large spread of capabilities and an easily-handled approach to programming. It provides straight-ahead remote "learning" capacity with two more-exotic modes: command sequencing and timer programming. If proliferation of remotes is indeed a problem in your household—or if you simply want a nifty little gizmo at your command—*Realistic's Universal Remote Control (URC)* rates a look.

The hand-held unit is a little over 1.5-inch thick, but it rests on an inch-high battery compartment that gives it a 20° tilt. It's a little larger than most remotes, at almost nine-inches long and a little over three-inches wide, but the black plastic module fits easily in the hand, or rests comfortably on four rubber spacers at the corners of the bottom panel. The back holds a door to the battery compartment (the unit uses four "AA" batteries) and a short, handy sum-up of the directions for use. The bottom end has a small window, through which the URC learns the commands of the controls it replaces, while the

top end has the dark, transparent-to-infrared window. There is a recessed reset control built into the battery compartment and a small button on the left side that controls a green illuminator to the right of the LCD display. The majority of controls, naturally, are concentrated on the front panel.

The eight-digit LCD (2¾ inches by ¾ inch) is large and easy to read, although located farthest from the user at the top of the front panel. Several messages ("Begin," "Stored," "Error") can be displayed in large letters on the LCD, which reverts to a digital time reading when not in use. The LCD also has status and device indicators—the latter being eight separate modes that can be programmed, including television, VCR, cable controls, and two auxiliary channels. Below the window are eight main control buttons, for power, volume, channel selection, device selection (designated SELECT), and a mute switch. A 21-key console below that features sequencing controls and various unit-specific controls, such as rewind and fast-forward for the VCR. Also, there is an eight-button panel with controls for the URC itself, and, at the very bottom of the unit's front, a recessed switch for the "run" and "learn" modes.

Programming is fairly straightforward, though it is essential to keep the "device indicator" modes straight in order for the user to remember what the URC has been

taught. We programmed the commands of a Sony RMT-156 and RMT-318, as well as a Panasonic P42 and P38; all those are VCR remotes. We also transferred the commands from a Sony Trinitron-TV remote and a cable-box control.

The *Realistic* instruction manual warns, "a few remote controls use IR frequency-variation commands, and the URC can't handle those." But we were unable to locate any such remotes for testing.

Sequencing was pure pleasure with the URC. We were able to sit down, flick two buttons (VCR "POWER" and "#1" sequence button) and watch as the television came on, the correct channel was automatically selected, the VCR powered up, and the recording of a movie begun. The entire process took 10 seconds, as opposed to the five-minute ordeal in a remote-less household. The URC actually increases the probability of taping any given program, since the recording process becomes so much easier. In addition, the URC's timer mode can trigger the same process, so the user's presence isn't required for recording to begin.

Home-video enthusiasts will perhaps make the most use of the URC, but any *Gizmologist* can appreciate its time- and labor-saving qualities. Ease of programming and use, sleek design, and dependable operation combine to make the *Realistic Universal Remote Control* one of the best of its kind. ■

Super Blocks Telephone

Has anyone ever figured the percentage of the collective business and work day in the United States spent on "hold?" There seems no end to telephonic waiting, which is where the new *Super Blocks Telephone* from *Tyco Industries* (6000 Midlantic Dr., Mt. Laurel, NJ 08054) comes in. We wouldn't go as far as the product press release, which proclaims "being put on hold is a welcome relief," but the unique telephone at least gives the caller something to do with his or her hands. Namely, reconfigure the instrument with the "snap-together building blocks" that adorn this phone. There are 18 of the green, yellow, red, blue, and black blocks, neatly stored in a drawer on the side of the base. In its non-architectural aspects, the Super Blocks instrument features a pulse/tone switch, last-number redial, and a mute button. Since the phone features Tyco Super Blocks, if there's another set around the household, the user can keep adding further structures as the "hold" stretches into infinity. Price: \$54.99.

CIRCLE 57 ON FREE INFORMATION CARD



Super Blocks Telephone

Solar-Charged Garden Sprayer

Sun-filled days of summer gardening, fighting off pesky insects, and broadcasting herbicides and fertilizers have spawned a new ecologically-sound accessory, a *Solar-Charged Garden Sprayer*. As described in the catalog from *Hammacher Schlemmer* (147 E. 57th St., New York, NY 10022) the 1.95-gallon-capacity, battery-powered sprayer features a nylon hose, jet-cone nozzle, and is capable of operating for up to three hours. Spray adjusts from mist to solid stream and has a range of up to 30 feet. What's unique is that the 6.5-amp power pack can be recharged via a 13-inch by 13-inch solar panel. Its capacity, according to the catalog, is enough to "treat" an acre of land. Price: \$620.

CIRCLE 58 ON FREE INFORMATION CARD



Solar-Charged Garden Sprayer

Illuminated Umbrella

According to *Hammacher Schlemmer* (147 E. 57th St., New York, NY 10022), the "principles of fiber optics" are now being utilized in the design of that decidedly low-tech rainy-day appliance, the umbrella. Specifically, an *Illuminated Umbrella* featuring an internally lit shaft, visible from up to a 100-yards away. The sealed, waterproof plastic handle contains a 4.5-volt bulb that transmits a soft, luminescent beam. Red, green, blue, or violet chips fit into a slot in the handle and control the color of the radiated light. The white nylon canopy opens to a 41-inch diameter. Power is supplied from three "C" batteries (included). The light-casting bumbershoot comes with a clear plastic storage case. Price: \$64.95.

CIRCLE 59 ON FREE INFORMATION CARD

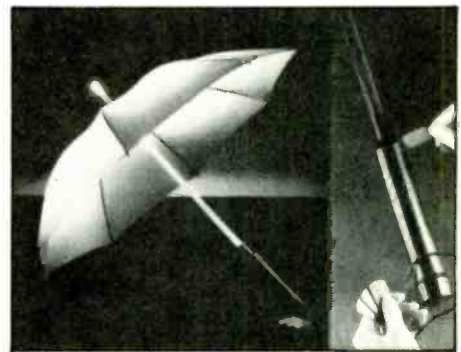

Illuminated Umbrella

VCR with On-Screen Programming

Here's a good example of the "trickle down" theory (and practice) of consumer-electronics technology. On-screen programming was all the upscale rage a couple of seasons ago. Now, *Shintom West Corp. of America* (20435 S. Western Ave., Torrance, CA 90501), in aggressive pursuit of the mass market, is offering the flashy capability on a budget-priced VCR (*VCR-4600N*). Besides on-screen graphic display of time, preset channels, timer recording, off-time indicator, channel, and mode, the VCR-4600N features remote one-touch recording, automatic on/off, play, replay, rewind, and tape eject. In extended-play mode, the unit is capable of freeze frame and single-frame advance. Judging from the description in the product's press release, recording is limited to preset intervals: "the one-touch recording system can be selected for .5, 1, 1.5, 2, 3, and 4-hour periods." Price: \$329.95.

CIRCLE 60 ON FREE INFORMATION CARD



Shintom VCR

Factory F2 Knife

Seeking to capitalize on a best-seller, *Plus U.S.A. Corp.* (10 Reuten Dr., Closter, NJ 07624) has introduced a lower-priced update of its *Factory Folding Knife*, the new F2. The original, and still-available, accessory features nine swing-out, miniature desk tools. The new F2, available in black only, has eight: stapler, carton opener, ballpoint pen, storage case, scissors, screwdriver, staple remover, and "D-ring" and was scheduled to be in stores by July. Price: \$19.95.

CIRCLE 61 ON FREE INFORMATION CARD

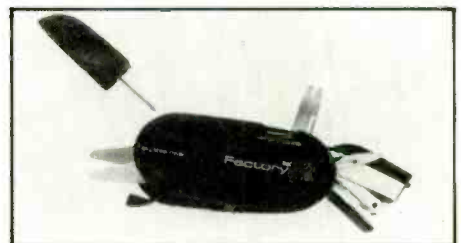

Factory F2 Folding Knife

Gizmo/Bytes

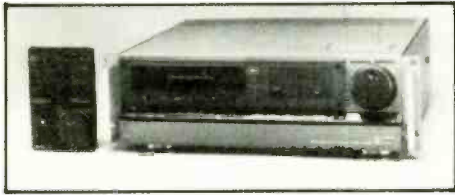

Extended Definition Beta VCR

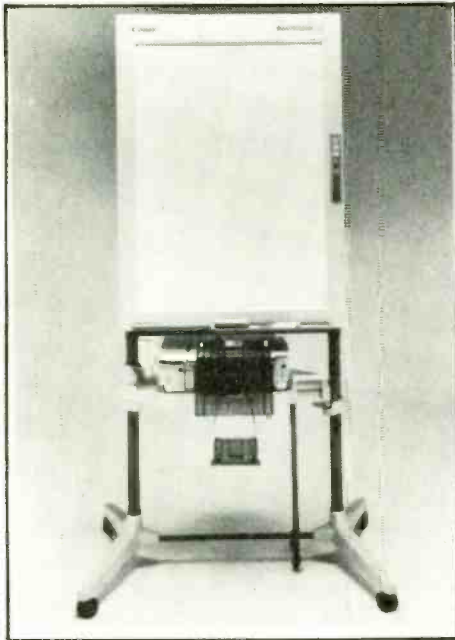

Electronic Whiteboard

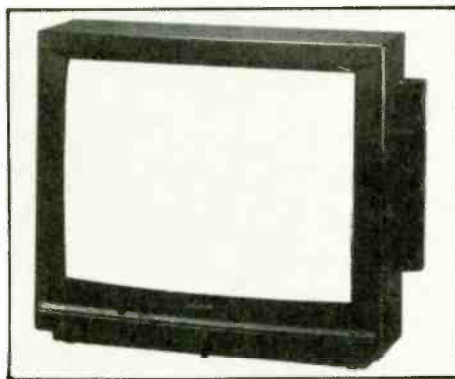

Table-Top Prism TV



NotePad Plus Telephone

Extended-Definition Beta VCR

Everyone has heard, over and over again, that the Beta format has been completely overtaken by VHS in the home-video market. That doesn't mean, however, that Beta is without its ardent supporters, including, most importantly, *Sony Corp. of America* (9 W. 57th St., New York, NY 10019), which in June proudly unveiled the *ED Beta Videocassette Recorder (EDV-9500)*. Targeted to the "sophisticated video customer" Sony dubs a "prosumer," the extended-definition system yields over 500 lines of horizontal resolution. Eight-bit digital picture functions include exceptional still/slow and stop motion, flash motion (described as picking up "single field signals and displaying them at variable time intervals from 1/16th of a second to two seconds"), single-frame advance and "Noiseless BetaScan," which permits viewing a taped image, forward or reverse, at speeds up to fifteen times faster than normal sans "any picture noise." Editing features include a "jog-shuttle dial" (variable-speed search in both directions) with bi-directional speed capabilities from freeze frame to twice normal speed; "Dual Flying Erase" heads and an "8-segment programmable assemble-editing capability." Also, command information can be sent between the master and duping decks, and an electronic "Tab Marker Indexing System" allows random access to any of 19 possible positions on a tape. An on-screen counter shows hours, minutes, seconds, and frames. The unit's remote can control "all VCR and color-TV tuning functions." Price: \$3,300.

CIRCLE 62 ON FREE INFORMATION CARD

Plain Paper Electronic Whiteboard

So-called electronic copyboards or whiteboards are a big-ticket communications devices that can make copies of material written on or attached to the boards and, in the case of the *Boardcopier A-1* from *Canon U.S.A., Inc.* (1 Canon Plaza, Lake Success, NY 11042) can copy in five colors (red, black, brown, blue, and green) and its attached copier "can double as a stand-alone personal copier." Canon's main theme in marketing the A-1 is its plain-paper capabilities. Other units use thermal paper. The product release also explains, "a whiteboard, unlike its predecessor the blackboard, can make copies of information written on or attached to its screens." If you're comparison shopping, this one uses a vertically scrolled, continuous two-sheet screen whiteboard. The entire unit weighs 89 pounds and is mounted on casters. Price: \$2,395.

CIRCLE 63 ON FREE INFORMATION CARD

Prism Table-Top Television

The electronic appliance that used to be called the "boob tube" took another leap in May with *Panasonic's* (1 Panasonic Way, Secaucus, NJ 07094) introduction of the new Prism line of televisions. Those ultra-advanced consumer sets feature menu-driven intelligent remote control, on-screen menu display, wide-band video amplification, and S-VHS video inputs. The *Prism Table-Top Television (CTK-2090S)*, one of three models, uses the "Panasonic AberrationReducing Triode" picture tube for "outstanding clarity" and a "natural-looking picture with reduced edge distortion." The CTK-2090S remote control is directed by a "multi-color Prism on-screen menu" and can "learn the major commands of most other infrared remotes." Following the screen graphics, viewers control "almost all TV features and adjustments...color, tint, brightness, graphic equalization, and channel selection." In its audio aspects, the CTK-2090S offers four speakers enclosed in separate boxes at the side of the 20-inch screen. The set is 155-channel cable compatible. Price: To be announced.

CIRCLE 64 ON FREE INFORMATION CARD

NotePad Plus Telephone

So, why not a telephone with a built-in notepad for doodles and potentially more useful scratchings? Especially as the idea is realized by *TeleQuest, Inc.* (7740 Kenamar Ct., San Diego, CA 92121). Dubbed the *Notebook Plus Telephone*, it's a desk/wall convertible instrument with a 5-by-8-inch note pad and ballpoint-pen mounts. The note pad and pen that are included can be replaced. The telephone features nine-number memory, illuminated handset dial with recall, a hold function with LED, and tone/pulse-dialing capability. The handset cord is ten-feet long and wraps behind the base for wall mounting. Price: \$39.95.

CIRCLE 65 ON FREE INFORMATION CARD

Supra Telephone Headset

Telephone security is a long-standing military and intelligence concern, which is probably why *Plantronics, Inc.* (345 Encinal St., Santa Cruz, CA 95060) introduced its new *Supra Dynamic Headset* at last year's Armed Forces Communications and Electronics Show. What makes that lightweight telephone headset, for use in "low-noise, high-security environments," noteworthy is its use of a dynamic microphone, eliminating the need for an external power source. Non-amplified single-channel reception via receivers built into the earpieces and a varistor protects against unexpected loud noises. The system is outfitted with a push-to-talk switch and has a 42-inch cable and a 15-foot coiled cord. Initially, Plantronics announced, the "Supra Dynamic will only be available through government, military, and civil-agency contractors, using standard procurement procedures." Price: \$225.

CIRCLE 66 ON FREE INFORMATION CARD

Bass Boost Personal Cassette Player

Today, big, detailed, musical sounds come in small, personal-size packages, like the *Bass Boost Personal Cassette Player (JC-K15G)* from *Sharp Electronics Corp.* (Sharp Plaza, Mahwah, NJ 07430-2135), which features bass-enhancement circuitry. The case is coated with a special non-smudge "Durasilk" surface, while the player features auto-reverse, Dolby-B noise reduction, metal-tape capability, and an LED power indicator. Price: \$129.95.

CIRCLE 67 ON FREE INFORMATION CARD

Personal Protection Products Catalog

"In today's society, personal security is no longer guaranteed. The alarming increase in violence, drug abuse, and terrorism... has contributed to a sense of fear and helplessness." Those words come from a party with a specific interest in the problem, *Personal Protection Products* (405 Park Ave., New York, NY 10022) and introduce the company's *Catalog*. The 28-page all-color booklet lists its share of esoteric (and high-priced) electronic gear: a video-transmission system hidden in a book, an attache-case video camcorder, super-sensitive microphones, and the like, as well as such traditional favorites as bullet-proof vests and wristwatch cameras. The catalog's price is credited towards an initial order. Price: \$2.

CIRCLE 68 ON FREE INFORMATION CARD

"Talking" Clock Radio

One of the more common of everyday conveniences, the clock radio, seems to inspire more than its share of off-beat innovation. *Sony Corp. of America* (9 W. 57th St., New York, NY 10019) includes a model in its "Dream Machine" line, the *ICF-C88W*, which incorporates a memory chip and microphone to allow the user to pre-record an eight-second message that the device can use (instead of the radio or buzzer) as the alarm signal. A dream bar offers eight minutes of additional sleep after the alarm sounds. There's a three-position brightness control and backlighting of the radio dial enhances visibility in the dark. The wedge-shaped "talking" clock radio is styled in gray and white. Price: \$59.95.

CIRCLE 69 ON FREE INFORMATION CARD

Oral Care Center

Irrigation is an important activity, not only in agriculture, but in taking care of teeth. *Braun, Inc.* (66 Broadway, Rt. 1, Lynnfield, MA 01940) now offers dedicated oral-hygiene activists the *Oral Care Center (OC30)*, which includes a "cordless rechargeable toothbrush and an oral irrigator with patented multi-function irrigating tips," meaning the tool allows users to select mono-jet air and water, or multi-jet action. The toothbrush itself "features a unique brushing motion: combined vertical and horizontal strokes at 3,300 times a minute," including a "small multi-tuft brush head with over 1,000 rounded ultra-slim nylon bristles." Reviewed and rated "provisionally acceptable" by the American Dental Association, the OC30 Oral Care Center has been available since May. Price: \$89.99

CIRCLE 70 ON FREE INFORMATION CARD

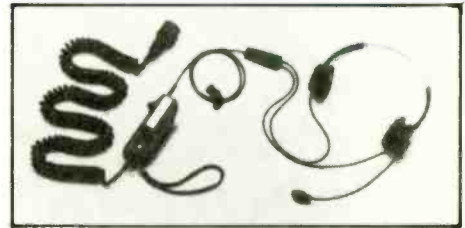

Supra Telephone Headset



Bass Boost Personal Stereo



"Talking" Clock Radio

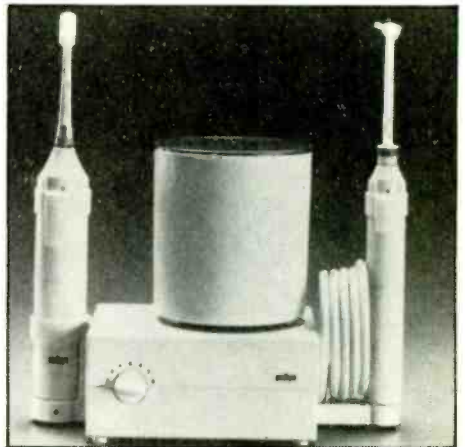

Oral Care Center

Gizmo/Bytes

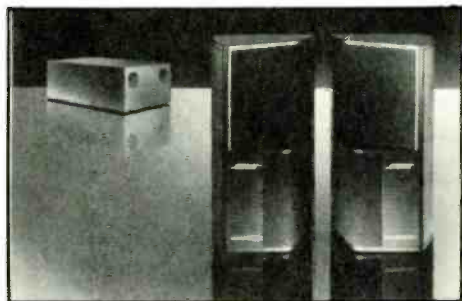

Acoustimass Stereo Everywhere System

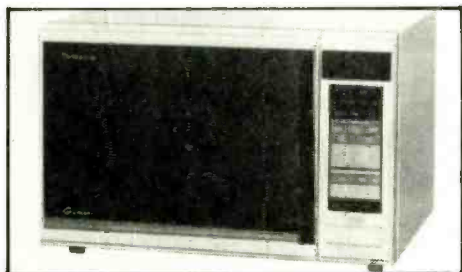

Gemini Microwave Oven



Camcorder Carryall

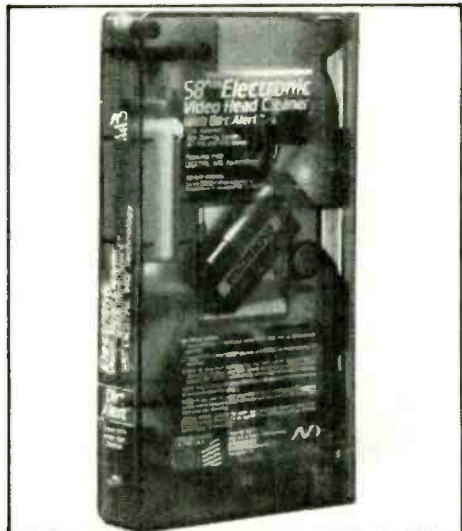

Dirt Alert Video Head Cleaner

Compact Acoustimass Speaker System

Speaker technology has given birth to some spectacular advances in consumer audio and certainly one of the most intriguing are the systems from the *Bose Corp.* (The Mountain, Framington MA 01701) utilizing the company's "Acoustimass" technology. The newest addition to what Bose calls its "family" of "Point Two" products is the *Acoustimass Stereo Everywhere Speaker System (SE-5)*, delivering "the bass, power handling, dynamic range, and spatial accuracy of a much larger system." The SE-5 is said to offer "pure sound" (a question we'll leave to the guys in the white lab coats) and "virtual invisibility," achieved through the system's Acoustimass module, a bass source that allows "the listener [to] remove the bulkiest part of a loudspeaker system from view." In controlled demonstration, the SE-5 delivered exceptional and impressive sound from a CD system. Which we think is what the techno-listeners mean when they talk about audio "imaging." For a product said to be virtually invisible, the SE-5 is housed in an exceptionally handsome (and acoustically sound) case. Price: \$699.

CIRCLE 71 ON FREE INFORMATION CARD

Bake and Broil Microwave Oven

Baking has never been something microwave cooking does well, but the *Panasonic Co.* (1 Panasonic Way, Secaucus, NJ 07094) says its new *Gemini Microwave Oven (NN-8907)* tackles that long-standing culinary shortcoming. The NN-8907 (and a companion model, *NN-8507*) incorporates a flat heating element in the oven's ceiling and floor, transforming the surfaces into "a solid heating plane." Those elements also, "eliminate the need for a convection recirculation fan." Uniform heat radiation provides "even browning when baking, broiling, or roasting foods." The NN-8907's oven is 1 cubic foot and features a ceramic turntable, automatic reheat, weight defrost, time defrost, and 6 power levels. Price: \$399.95.

CIRCLE 72 ON FREE INFORMATION CARD

Camcorder Carryall

When it comes to lugging all those fast-selling camcorders and video recording accessories around, *Coast Manufacturing Co.* (118 Pearl St., Mt. Vernon NY 10050) is in the video enthusiast's corner. The firm's *Caravelle Camcorder Carryall (PL-200)* provides a double-zippered top, dense polyfoam inner-wall construction, with Velcro-adjustable dividers inside. The exterior is "patch leather," sewn together in eye-catching patterns in chocolate or tan tones. A saddlebag front pocket provides roomy additional storage for accessories, with special compartments for camcorder documentation, writing instruments, and the like. The bag is outfitted with both hand and shoulder straps. Price: \$150.

CIRCLE 73 ON FREE INFORMATION CARD

Consumer Video Brochure

If you're sincerely willing to admit (at least in the privacy of your own home) that you're still confused by some aspects of home video, there's a booklet, *Video Know How* that the VCR mavens at *Sharp Electronics Corp.* would be glad to send you. It explains "tips and terms" in the usual question-and-answer format about TVs, VCRs, and camcorders. To receive it, just send your name and full address to: *Consumer Video Brochure*, P.O. Box 9319, Trenton, NJ 08618. Price: free.

CIRCLE 74 ON FREE INFORMATION CARD

Dirt Alert Video Head Cleaner

Fans of effortless home entertainment will want to know about yet another robotic accessory for automatic VHS enjoyment. It's the *Dirt Alert Electronic Video Head Cleaner (58-P)* from *Advanced Video Dynamics, Inc.* (705 General Washington Ave., Norristown, PA 19403). That item knows when it's time to clean a VCR's heads, even when the user doesn't. The first time the cleaner device is used, it self-sets a 30-day countdown. When the Dirt Alert red light flashes, it's time to slip the cleaning tape into the cassette bay. The light will continue flashing the clean signal for 15 days. Cleaner fluid is automatically dispensed by the system and a beep signals the end of the cleaning session, usually 30 seconds. According to the manufacturer, a Dirt Alert Video Head Cleaner should be good for 30 to 35 cleanings, estimated to be two or three years worth. Price: \$29.95.

CIRCLE 75 ON FREE INFORMATION CARD

Auto America Car Stereo Head Unit

If you're the owner of a domestic car, but desire the performance and prestige of a European-designed vehicle stereo system, *Pioneer Electronics (USA), Inc.* (2265 E. 220th St., P.O. Box 1720, Long Beach, CA 90801-1720) has considered your plight. The Deutsch Industrie Norm (DIN) *Car Stereo Head Unit (KE-4060)* "in addition to fitting foreign vehicles will now fit flush in the dash of domestic cars," Pioneer says. The KE-4060 offers AM/FM radio, auto-reverse cassette, Dolby B, metal-tape capability, and memory-scan tuning. The same model is available in an anti-theft configuration (*KE-4060QR*) for easy removal and re-installation by the vehicle driver. Price: \$340.

CIRCLE 76 ON FREE INFORMATION CARD

Low Impact Climber

What exercise can burn off calories faster than calisthenics, cycling, rowing, or jogging? *Precor USA* (20001 N. Creek Pkwy., P.O. Box 3004, Bothell, WA 98041-3004) says that one of the most unglamorous forms of exertion, stair climbing, is considered by many trainers to be "the best single combination of aerobic and anaerobic exercise." Hence the equipment firm's *Low Impact Climber (718e)*. Quiet and smooth in action, the 718e includes a computerized instrument panel with time, pace, and distance information. Advanced users will want to try navigating the 718e with a full bag of groceries in each arm. The entire unit takes up "less floor space than a console TV." Price: \$425.

CIRCLE 77 ON FREE INFORMATION CARD

Super Directory

Credit-card-size directories are well on the way to becoming an everyday tool of the electronic era. The *Super Directory* distributed by *Executive Communications Systems* (2622 Quaker Ridge Pl., Ontario, CA 91761) offers 8K memory for more than 450 names and numbers. A 16-item checkbook feature helps the user keep track of multiple accounts. Also included are access code, calendar, and dual time-zone features, as well as 25 appointment alarms—when one goes off, the name, event, or date signaled shows on the display. All of that concentrated memory power weighs only 1.06 ounces. Price: \$49.95.

CIRCLE 78 ON FREE INFORMATION CARD

Light Weight Digital Stopwatch

What more could the user ask from a *Light Weight Digital Stopwatch (SW1)* than the capacity to count down (or up) to 24 hours at one-second intervals? The SW1 doubles as a standard digital timepiece (in either 12- or 24-hour modes) and at 1 ounce, is light enough to be worn around the neck. In its stopwatch mode, it measures accumulated elapsed time, split time, or time between two competitors. There's also a calendar function. Its distributors, *NDQ Marketing* (999 6th Ave., New York, NY 10018), a subsidiary of Hattori-Seiko, says its "laser-regulated quartz movement provides a high level of accuracy." The display can alternate between time and stopwatch functions, holding both readings, at the click of a button. Price: \$9.95.

CIRCLE 79 ON FREE INFORMATION CARD

Twin Handset Telephone

If like a lot of consumers, you don't think much of speakerphone conversations, consider the *Twin Handset Telephone (T3125)* from *Yorx Electronics Corp.* (405 Minnissink Rd., Totowa, NJ 07512). That two-line instrument with 20-number memory, LED line-indicators, universal pulse/tone dialing (for use on rotary or touch-dia. telephone lines), buffered memory keyboard, and a three-position ringer; it also has a conference-call capability for three-way conversation. Other features include call holding with an LED "on hold" indicator. Price: \$74.95.

CIRCLE 80 ON FREE INFORMATION CARD



Computerized Stair Climber



Super Directory

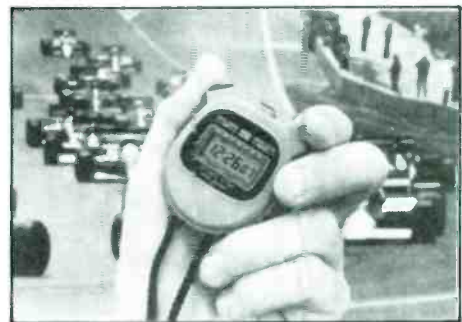

Digital Stopwatch

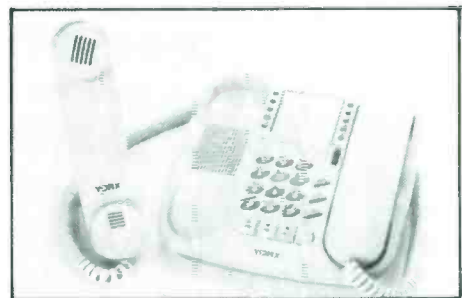

Twin-Handset Telephone

KITES

AS ANTENNA SUPPORTS

Next time someone tells you to go fly a kite, take their advice and get and give better signals for SWL'ing and hamming

By Stan Gibilisco

THE IDEA OF USING KITES AS ANTENNA SUPPORTS FOR low, medium, and high frequencies is as old as the radio art itself. Marconi used a kite to support his receiving antenna during the first transatlantic tests. In recent years, with proliferation of very-high, ultra-high, and microwave-frequency operation, we have been hearing less and less about long wires and their means of support. But much communication still takes place at the lower frequencies and there aren't many inexpensive ways to get long antennas up high for DX.

Helium-filled balloons and kites are the best way to do just that. Either method works surprisingly well for a very small expenditure of money.

Here, we will examine the use of kites as antenna supports. Hopefully the ideas and experiences here will help others to make more use of this method of antenna support.

Lifting Power of Kites

Even a small kite can provide a surprising amount of lift. There are literally hundreds of different kinds of commercially manufactured kites, mostly available in small stores and department stores for use by children. Those kites will provide very little pull, so that a youngster will be able to manage them and will not lose them or be likely to have an accident. Such kites may still give enough lift for some

antenna applications, but in general, larger kites are preferable for serious DX work. They are more stable and will hold up more wire without slackening.

Some kites have more lifting power than others, even for the same size. Probably the most lifting power is provided by the large parafoil kites, which are shaped something like parachutes and fly by means of the airfoil principle as well as by wind resistance. Some parafoils require winches for flying because the pull becomes so great that it is impossible to bring the kite down by more traditional means.

Lifting power is specified according to the line strength needed for flying a kite. Manufacturers may specify 30-pound, 50-pound, 100-pound or greater line strengths. The lifting power depends, too, on the wind speed. For a given kite, the greater the wind speed, the more it will pull.

Safety

Kite flying can be dangerous, and that is especially true when the line is a conducting wire. Kite manufacturers do not want to be responsible for injury resulting from electric shock, and they therefore warn you never to fly a kite with a conductive line or when the string is wet. And yet, for radio communications, that is exactly what we need to do.

There are two dangers from using conductive lines to the kiteflier: power lines and atmospheric static. It is imperative

that kites not be flown where the wire might fall on a power line. In or near thundershowers, large voltages may build up on the wire and they can be lethal. In fact, even in the absence of an electrical storm, it is not unusual for a large enough static charge to develop so as to produce a spark up to ½-inch (about 1.2 centimeters) long.

It is mandatory that there be no above-ground power lines within a distance of the antenna feed point equal to the length of the wire being flown. Static discharge will usually not be dangerous unless the wire is more than about 400 feet (130 meters) long.

Transmitting

If the antenna is used for transmitting, there is the possibility that it will come down while power is being fed into the wire. That may cause RF burns for anyone who happens to touch the wire. Also, damage may be done to television or radio equipment if the transmitting antenna comes into contact with the television or other antenna. The best means of protecting against that is to constantly monitor the antenna standing-wave ratio (SWR) and, if a sudden change occurs, cease transmitting and find out the cause of the change.

Other than those considerations peculiar to radio antennas that are supported by kites, all kite flying rules should be obeyed. The only restriction according to the Federal Aviation Administration concerning kites under five pounds (about two kilograms) is that they not present a hazard to people, property, or aircraft. Reasonable caution will ensure that fun experiments do not turn into nightmares.

Kites for Various Wind Speeds

Generally, it will be necessary to have two or maybe even three different kites available, for given wind speeds. Table 1 shows the types of kites that are best suited for various wind-speed ranges.

The delta wing is probably the best for very light winds. The sled will also work, but has less lifting power than a large delta. The largest deltas may be over 12 feet (4 meters) in wing span and still weigh less than a pound (400 grams). They fly at high angles in winds of as little as 4 to 5 miles per hour (mph) and up to 15–18 mph. Above 18 mph they tend to become unstable and do loops and dives, and they may crash. At speeds less than 4 mph they will settle, although they can hover for some time during a lull, and may even ride thermal updrafts, turning in circles directly overhead.

For medium winds the parafoil is a good choice. It flies at a high angle compared with most other types of kites and is stable in lulls and gusts. The parafoil, in my experience, works best at wind speeds from about 15 mph to 25–30 mph. At speeds greater than 30 mph, even a small parafoil pulls very hard and becomes difficult to handle.

TABLE 1
PREFERRED KITE TYPES FOR
VARIOUS WIND SPEEDS

BEAUFORT NUMBER	SPEED, MPH	PREFERRED KITE TYPES
0,1	0-3	None
2	4-7	Delta, Sled
3	8-12	Delta, Sled
4	13-18	Delta, Parafoil
5	19-24	Parafoil, Ram
6,7	25-38	Ram
7+	39+	Not recommended

For higher wind speeds, in the range of 20 mph up to near-gale force of 35–40 mph, a kite called the ram works best. That kite lets much of the air through, and does not pull very hard even in the strongest wind. The kite is stable, but flies at a somewhat lower angle than other kites.

The traditional bow kite, with a tail, is not a very good choice, since such a kite is better suited for stunt flying. The kites that are best for antenna work are those that will fly with a minimum of attention. The idea, in fact, is to be able to ignore the kite completely and get on with the business of hamming or shortwave listening. I have a friend who is into shortwave listening with kite-supported longwires; he had one kite unattached for 488 hours on his farm. (He had little to worry about if it came down; there were only empty fields for the kite to land in.) The important factor is stability and ease of flight.

The best location for kite flying is either on the windward side of a hill, or on a plain where there are no ground irregularities at all. The wind tends to rise upward along the windward side of a hill, but turbulence occurs at the crest and especially on the leeward side of the crest (Fig. 1). I live just past the crest of a hill on the northern side and have continuing problems with winds from the south, southeast, and southwest. Winds from the north and northwest are much more stable even though kite flying in such winds makes it necessary to hang the kites over the neighborhood where they attract attention. There is no question; using kites as antenna supports puts your hamming or SWLing in the hands of Nature to a large extent.

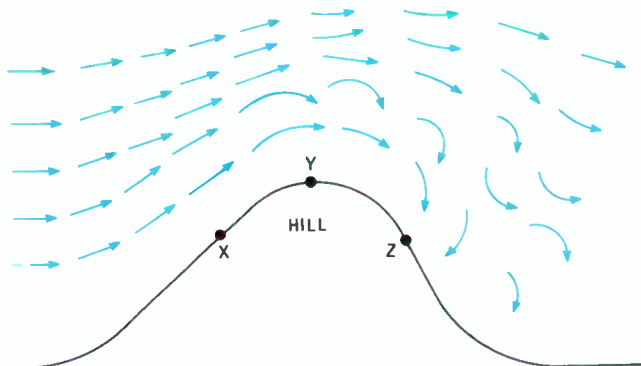

Fig. 1—This is an illustration of wind circulation over a hill. The best points for kite launching are on the windward side (X). The crest of the hill (Y), and especially the leeward side (Z) are subject to turbulence, although a high-flying kite can sometimes be used to get above the turbulence if launched from those points.

The variability can actually be fun, since working or hearing a rare DX station using a kite antenna can give a feeling of having used the fickle powers of the wind to an advantage that could not otherwise be attained. I imagine it's something like surfing the perfect wave. If it was too commonplace it would lose some of its magic.

Flight Angle

Normally a high flight angle is associated with less slackening of the wire for a given amount of pull. High-flying kites get the antenna up higher with less wire length, and thus less weight. Those are good things about a high flying angle, say, 50 degrees or more with respect to the horizon.

However, there are advantages to lower flight angles, too. The stability of a low-angle kite is generally better, and it is

possible to take advantage of the directional effects of long wires when the flight angle is lower. Long wires—longer than about 0.6 wavelength at the operating frequency—develop directional lobes that get more and more in line with the wire as the wire is made longer. Examples are shown in Fig. 2 for end-fed wire antennas of 0.5, 1.0, 1.5, 2.0, 4.0, and 6.0 wavelengths. At very long lengths, the wire produces gain as well as having directional characteristics.

The advantage comes when the angle of the lobes with respect to the wire matches or nearly matches the angle of flight of the wire with respect to the horizon. Then a sharp maximum of radiation or response occurs in the direction that the kite flies, and also in the opposite direction, right along the horizon. That low-angle radiation/response is ideal for DX. An example is illustrated in Fig. 3.

Minor lobes also occur when a wire is very long, and those make the antenna a good all-around radiator as well as a directional antenna. Therefore, excellent results will often be had in directions not matching the theoretical ideal. The fact that the current maxima occur so high above the ground, compared with more traditional antennas using trees or towers, is largely responsible for the high efficiency. There is almost no ground loss and low-angle radiation/response is not subject to the ground-induced attenuation that is so often a problem with low antennas.

The graph at Fig. 4 illustrates the length, in feet, for long wire antennas of various lengths as a function of the frequency in megahertz. Shorter antennas—0.6 wavelength or less—work best with high flight angles. Longer antennas will function well even when the flight angle is quite low.

High-angle kites fly in lighter winds and low-angle kites in heavier winds. The low-angle kites generally have more pull, which is necessary to keep a given length of wire from slackening till it hits the ground or some obstruction. Very long wires, flying at low angles, require tremendous tension to keep from going slack.

Choice of Wire

The wire itself should have the following characteristics: good conductivity; light weight; and high tensile strength. The best wire for that need is hard-drawn, aluminum welding wire such as alloy 5356, which is commonly available in spools of 1 pound (454 grams) and having diameters of 0.030 inch (0.762 millimeter) and up.

I have used the smaller wire diameters, equivalent to

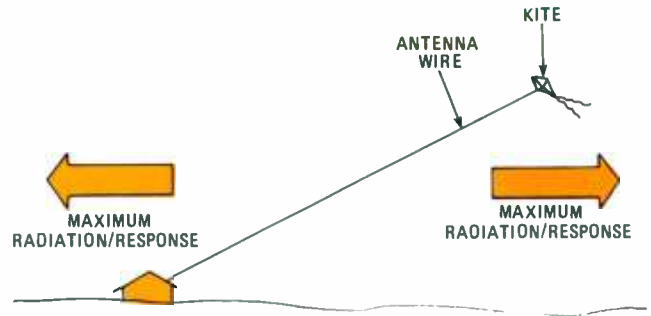

Fig. 3—A sloping, kite-supported long wire radiates well at low angles in the direction the kite flies, and also in the opposite direction, so long as the flight angle matches the angle of radiation relative to the wire.

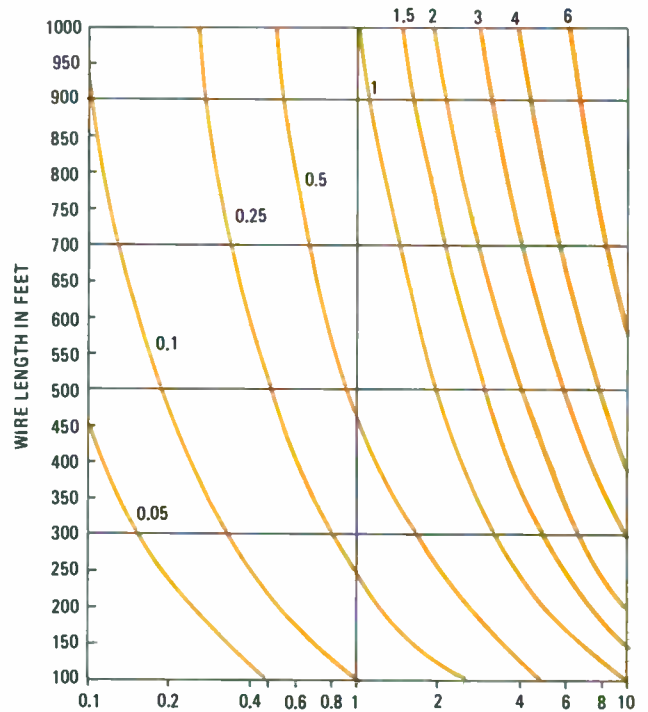

Fig. 4—Lengths, in feet, for end-fed long wires at frequencies from 0.1 to 10 MHz. Curves are labeled according to the lengths in wavelengths. For wire lengths in meters, multiply feet by 0.305.

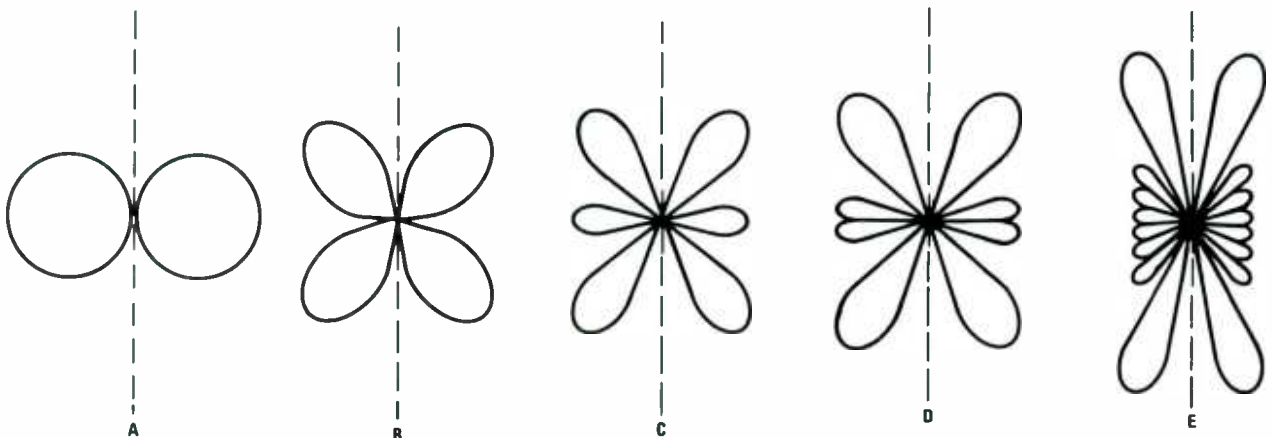

Fig. 2—Radiation patterns for 0.5 wavelength (A), 1.0 wavelength (B), 1.5 wavelength (C), 2.0 wavelength (D), and 4.0 wavelength (E). The dotted line represents the line of the wire.

approximately AWG 20 and 19 size, with success in conjunction with a medium-sized delta wing (wing span of 84 inches or a little over 2 meters) and a Ferrari ram kite having a size 4 square feet (0.37 square meters). A swivel is necessary at the point where the wire joins the kite. The smallest wire, 0.030 in (0.762 mm), will handle 500 watts of power at the amateur frequencies.

I use a spool intended for electric cord for winding up the wire. The spool has a circumference of about 18 inches (0.5 meter) per turn. For hard-pulling kites, a winch would be advised and heavier wire would be needed. The best method of keeping hard-pulling kites in tow is to use a separate kite line with rated strength as needed (for example, 150 pounds) and to run the wire parallel with it, letting the line bear the force.

It is essential that the wire not be allowed to kink, since that will cause breakage. When unwinding the wire from its spool onto the cord spool or winch, use a rubber band around the original spool to keep the wire from going crazy. The hard-drawn wire will retain its original coiled-up posture long after it has been taken from the original spool. It seems that the stuff never gets straight, even after hours of flying at high tension. So be prepared for that when reeling the kite in.

Set up

I set up the antenna by anchoring the cord spool by means of a belt that has holes all along its length. I simply secure the spool tightly to a wooden post or tree once the kite is at the desired altitude, and clip the feed line to the wire using an alligator clip. Quite often, especially if there is a lot of wire flying, a spark will jump from the feed line to the antenna as the two are connected. I have seen that spark jump as far as ½-inch (1.2 centimeters). I have been shocked by that voltage and, while not seeming dangerous, it is almost enough to make one let go of the spool. You don't want to do that, no matter what: The kite may come down on a power line, and if that happens, anyone touching the downed wire might be electrocuted.

If the aluminum wire breaks, it can be spliced, but there should not be very many splices in an antenna. Splices are more likely to break than straight wire. No attempt should be made to weld or solder a splice with aluminum wire, since heating will weaken the wire and aluminum does not take ordinary solder. Several twists, in the conventional accepted way, constitute the best splice. Sharp bends must be avoided since the wire will break at such a point.

Feeding and Grounding

The importance of a good ground with an end-fed long wire varies, depending on whether the antenna is to be used for transmitting or receiving, and on whether the length of the antenna is such that a current node occurs near the station end of the wire.

A good direct-current ground is always needed for electrical safety, and if the ground is also good at radio frequencies over a wide range, so much the better. A good radio-frequency ground for receiving can be obtained by laying several radial wires on the ground or burying them a few inches underneath the ground. The longest radial should be at least ¼ wavelength, if possible, at the lowest frequency contemplated. The shortest radial may be any odd multiple of ¼ wavelength at the highest frequency used. An example is shown in Fig. 5. That grounding system should be used in addition to an electrical ground connection.

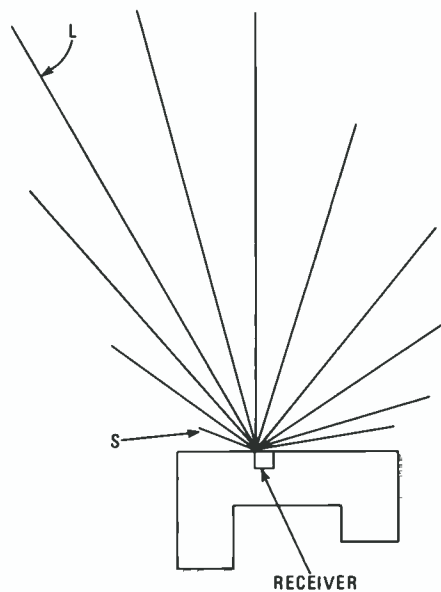

Fig. 5—Top view of a ground radial system for radio frequencies. The radial L is the longest; S is the shortest. Lengths are discussed in the text.

For transmitting, the best approach is to use antenna lengths that are near an integral multiple of ½ wavelength at the operating frequency. That is because current nodes (minima) tend to appear near the station end of the wire under such circumstances, and that reduces ground loss. That kind of feed requires a transmatch with a wide tuning range and the capability of matching very high resistive impedances. High radio-frequency voltages will occur at the station with such an arrangement, and that means there is an increased risk of arcing, and radio-frequency burns can result from touching the wire, even at modest levels of output power. However, this voltage-feeding technique is the simplest way to ensure high antenna efficiency.

The formula for determining the ideal length of wire L, for a given frequency f in megahertz, is:

$$L_{\text{feet}} = 492(N-0.05)/f, \text{ or}$$

$$L_{\text{meters}} = 150(N-0.05)/f$$

where N is the number of half wavelengths in the wire (N = 1, 2, 3, ...)

Zepping Up

One method of feeding that places the feed point away from the station is the so-called Zepp method. In that feed scheme, a balanced parallel-wire line is used, and the antenna is connected to one side of the line (Fig. 6). That requires that the antenna be almost exactly an integral multiple of ½ wavelength at the operating frequency to minimize radiation from the feed line. A transmatch with a balanced output is required.

The feed line itself may be tow-wire line, although for transmitting applications, homemade open-wire line is the best because it has low loss and can withstand higher currents and voltages than television-type ribbon line. Ideally, the antenna should be brought right down to the station, if possible, without being run near electrical obstructions. Then the antenna can be tuned over a wider range of frequencies without excessive feed-line losses.

(Continued on page 100)

MINI-MARQUE

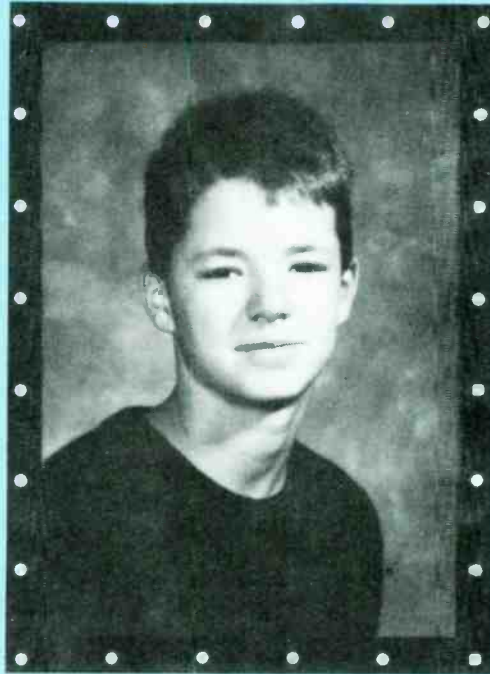

Display your photos in a flickering frame—a light show that the eye can't resist!

By Donald P. Ray

DID YOU EVER NOTICE THE ATTENTION-GETTING EFFECT of commercial signs with chase lights? Well, the *Mini-Marque* lets you add the same lighting effect to your favorite photograph. While many circuits have been devised to create various lighting schemes (some quite complex), the main objective here was to keep things as simple as possible, and to maintain a minimal parts count. The latter is of particular importance if the picture is to be wall mounted.

With that in mind, the circuit was built around a single integrated circuit (a hex inverting buffer), which is configured to provide a one-of-three sequence with enough output drive to light 24 LEDs. The circuit is powered from a 6-volt DC, 200-mA wall-mounted power supply.

How It Works

Figure 1 shows a functional diagram of the main part of the Mini-Marque circuit. Three gates of a CMOS hex inverter/buffer form an astable multivibrator (or oscillator) with a three-step output. When the power is first turned on, the outputs are initially floating high. The application of power causes C1, C2, or C3 to charge because of circuit instability. Let's assume C1 has charged, the output of that inverter, U1-a, goes low. The low output of the first inverter is fed to the second inverter (U1-b), causing its output to go high.

The high output of U1-b then causes the subsequent inver-

ter's output (U1-c) to go low, providing a discharge path for C1. As C1 discharges (once again applying a low to the input of inverter U1-a), the output of U1-a goes high, which in turn causes C2 to charge, and the cycle repeats. Without going any further, it can be seen that one output is always high, while the other two are low. The outputs go high in sequence at a rate determined by the RC time constant of the circuit.

Refer to Fig. 2—the complete schematic diagram of the Mini-Marque. Note that the oscillator of Fig. 1 is now com-

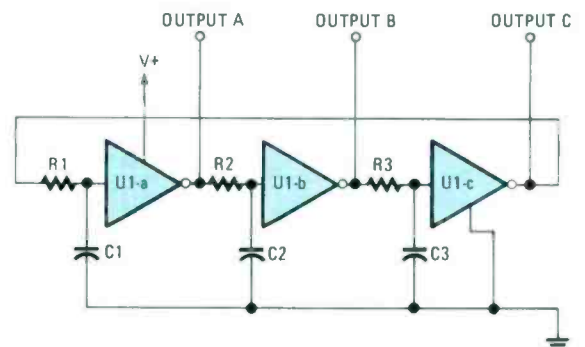

Fig. 1—This three step clock can be built around nearly any CMOS inverter, but high-speed types are not recommended because of their tendency to produce RFI.

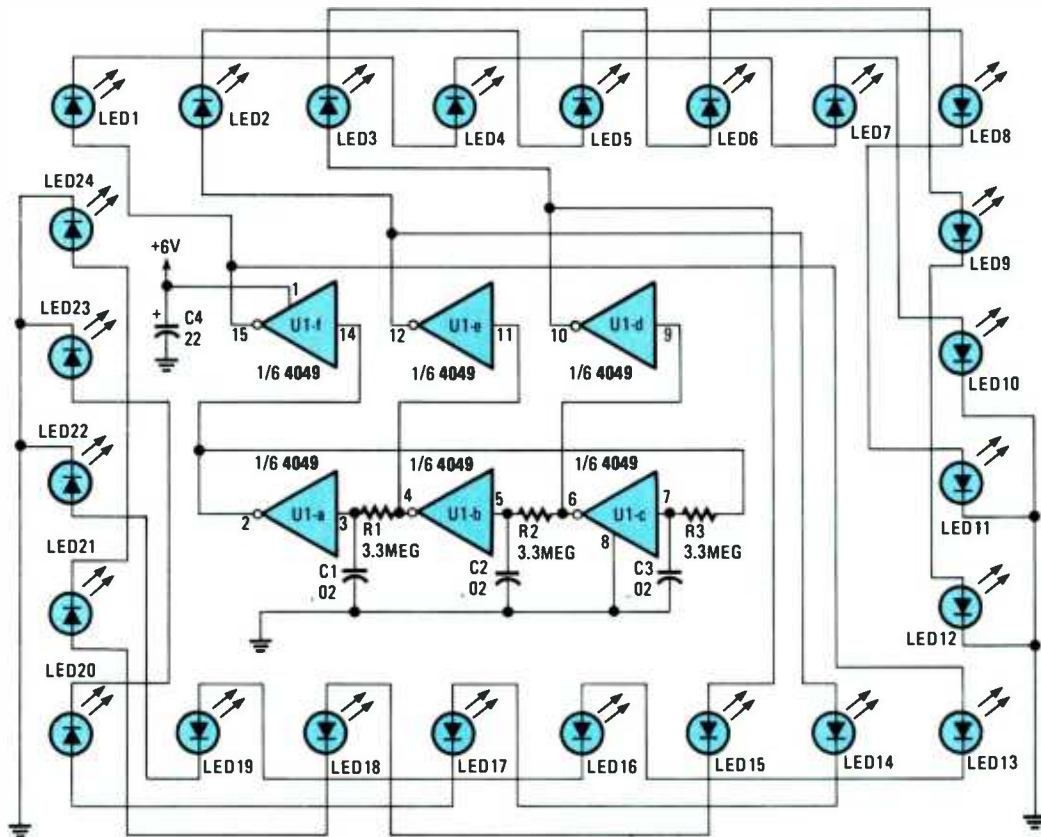

Fig. 2—The workhorse of the Mini-Marque circuit is a 4049 hex inverter/buffer. Three gates of the IC form a three step oscillator, while the remaining three gates are used to buffer the three oscillator outputs.

bined with additional circuitry to produce the desired lighting effect. The outputs of the three-step clock are buffered (and inverted) by the three remaining gates of the IC. The buffered outputs are tied to three sets of eight LEDs (which are series/parallel-connected in a four-by-four configuration).

As configured, the clock circuit provides a one-of-three "off" sequence, which is preferred to a one-of-three "on" sequence (with outputs sinking the LEDs). That permits 16 of the LEDs to be "on" at any one time, while 8 are off and seems to provide a more eye-catching display.

With the 6-volt power source indicated, no current-limiting resistors are necessary. However, it should be noted that, with a few minor adjustments, other circuits are possible. For instance, if a 9-volt power source were used, two sets of six series-connected LEDs might be tied in parallel to each output, for a total of 36. Some experimenting with the feedback resistors or input capacitors may be necessary to get the desired flicker rate.

Note: Although the integrated circuit used in the prototype is a 4049 hex inverting buffer, a little electronic "acrobatics" would allow nearly any CMOS hex inverter or inverting Schmitt trigger (such as the 74C04, 74C903, 74C14, 4584,

or 4502) to be used. Just be sure to take special note of the differing pinouts. And you may have to experiment with the feedback resistors to obtain the desired sequence rate.

High-speed CMOS hex inverters (like the 74HC14 and 74HC04, for example) also work, but are not recommended because they produce high-frequency harmonics that have a tendency to disturb nearby television and radio reception.

Making the Frame

The frame for the Mini-Marque was made from a sheet of clear acrylic plastic. Acrylic glazing is sold in hardware stores in sheets that measure 2×4 feet or larger, and in various thicknesses. Choose as thick a sheet as possible; thicker sheets are more rigid and are less likely to break or crack during drilling.

Refer to Fig. 3. Start by placing the chosen photograph on graphpaper (10 squares to an inch quad-ruled). Locate the centers for the four corner LEDs so that they are $\frac{1}{10}$ inch or more from each side of the photo. Now locate the remaining centers. There should be a total of 24 evenly spaced positions to accommodate the LEDs. Locating the centers may require some trial and error, especially if the photo is of an odd size or shape.

In some cases, it may even be easier to trim the photo to suit the LED spacing. For example, a standard 5×7-inch photo can be framed with 24 LEDs spaced one-inch apart by simply trimming about $\frac{1}{10}$ -inch from each side of the photo. Once the LED centers are located, remove the photo and draw the lines representing the inner edge of the frame, making sure that the frame slightly overlaps the photo.

Now draw the outside edge of the frame so that it is symmetrical with the inner edge and the LED centers. You

PARTS LIST

FOR THE MINI-MARQUE

- U1—4049 (or similar, see text) hex inverter/buffer
- LED 1—LED24—Miniature red light-emitting diode
- C1, C2, C3—0.02- μ F, ceramic disc capacitor
- C4—22- μ F, 16-WVDC Tantalum capacitor
- R1, R2, R3—3.3-megohm $\frac{1}{4}$ -watt resistor
- Acrylic glazing, hookup wire, solder, tape, 6-VDC 200-mA wall-mounted power supply (see text).

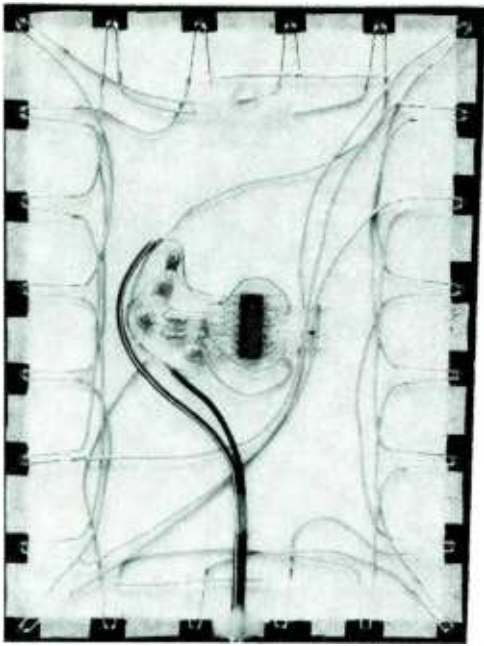

In assembling the prototype, the author first taped the photo to the frame, laid all components flat against the photo (with the IC pins bent outward), and then used point-to-point wiring to interconnect the parts.

After drilling all the holes, fill in the frame area with several coats of paint. It might make things go a bit smoother if you lay down tape at the edge of the area to be painted. (That's the same procedure that is often used to paint the trim in and around your home.) When the paint is dry, center the photo and tape it face down to the painted side of the frame.

Wiring the Circuit

Since the components are few, the author's prototype circuit was assembled using point-to-point wiring. That is best accomplished by soldering the components to the integrated circuit while it is held in a small vise. Remember that you are dealing with a CMOS integrated circuit, which is vulnerable to static-discharge damage, so be sure that you use a grounded soldering iron.

It is also a good idea to pre-tin all the component leads and integrated circuit pins with a clean soldering iron to avoid overheating the IC while soldering. A clean iron is a must because one encrusted with a carbon build-up requires longer contact with the component leads; increasing the possibility of component damage due to excessive heat.

Note from the photos that the pins on the integrated circuit are bent outward (as they are to be surface mounted) and all components are laid out flat, to keep the profile height at a minimum. (Likewise, the leads on the LEDs are bent inward, toward the center of the frame.) A bare copper wire is soldered to the pins that require several connections, making assembly easier. The positive lead of C4 must be soldered directly to pin 1 of the integrated circuit to remove the possibility of false triggering.

When all components are soldered to integrated circuit U1 (including two wires for each output), it can be mounted to the back of the photo with double-sided tape or contact cement. The LEDs can then be mounted with a drop of glue, and the remaining wiring can be done. For a final touch, a glob of epoxy holds the supply wires to the frame, and a hanger eye is pasted on the frame for wall hanging.

Trying It Out

After checking your wiring several times, plug in the power supply. If the LEDs don't sequence after about 3 seconds, unplug it and recheck your wiring. Make sure the LED polarities are correct and that no components are touching where they shouldn't. Also check the power-supply polarity and look for missing connections. If you still can't get it working, there's a possibility that the wall adapter is poorly filtered. Try adding a 10- or 22- μ F tantalum capacitor between the supply and pin 1.

Once the frame is happily sequencing, simply hang it on the wall and enjoy! If you want to display your Mini-Marque on a desk or table, you can make a stand from a piece of stiff cardboard and have the power-supply wires exit from the side, near the bottom.

Incidentally, the Mini-Marque makes an excellent gift. Think about it: For the sports fan, the frame might contain the picture of a favorite sports hero. For a young teenage girl, the frame might adorn the picture of the latest teen idol. Perhaps an auto racing fan might appreciate the picture of a favorite car and driver. Or for the boss, a picture of himself! ■

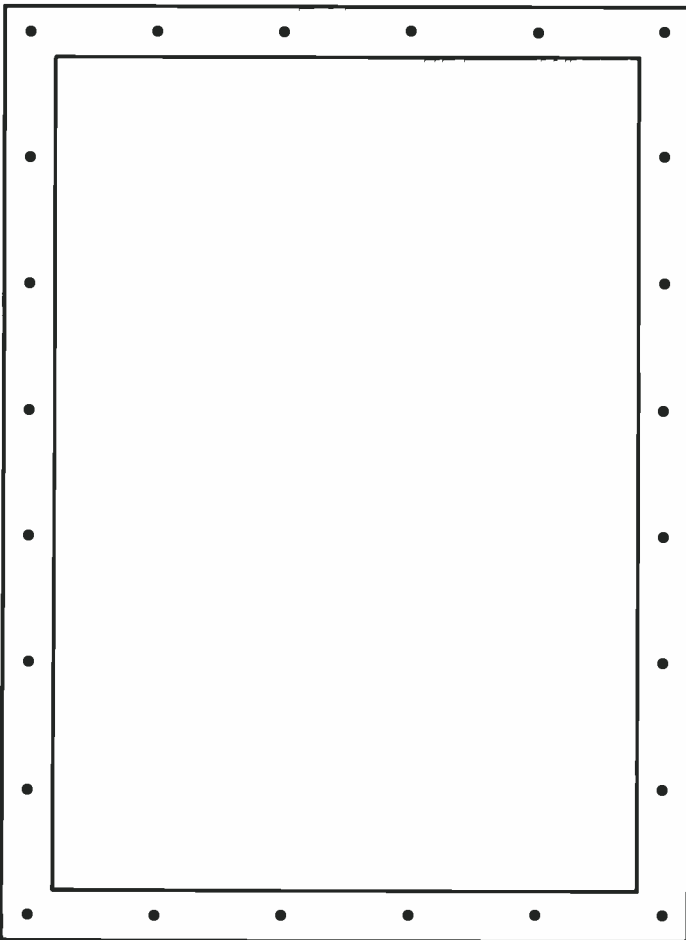

Fig. 3—Shown here is the typical layout for 5×7 inch photo. The inner boundary of the frame should be trimmed about 1/10-inch from each edge of the photo.

now have a pattern to use as a template for marking, cutting, and drilling your frame. Next, cut out the needed size of acrylic glazing with a plastic-cutting tip on a soldering gun, and smooth the edges with sandpaper. Afterwards, place the sheet of acrylic on top of your pattern, and draw in the inner edge of the frame and mark the centers for the LEDs.

PULSE SIGNALS

By Louis E. Frenzel

Pulses are used for logical operations, motor control, communications, and just about anything else you can think of. That's why you should read this article.

THERE ARE TWO BASIC TYPES OF ELECTRONIC SIGNALS—analog and digital. Analog signals are voltages or currents that vary smoothly and continuously over time. Sinewaves are the most-common type of analog signals. Digital signals are on-off pulses that switch between two different voltage or current levels.

The mathematical analysis of analog signals and circuits involves working with sinewaves and trigonometric functions. Analyzing digital signals and circuits makes use of numerous special math techniques. The math related to the charging and discharging of capacitors is particularly important. We discussed those last month.

In this installment, you will learn a mixed bag of math tricks associated with pulse and digital signals and circuits. Get out your scientific calculator, pencil, and paper, and let's get started.

Rectangular Waves

Any signal—analogue or digital—that is not a sinewave is said to be nonsinusoidal. The most common nonsinusoidal signal is a rectangular wave. Several examples are given in Fig. 1. Obviously, their name is derived from their shape. Those waveforms switch between two different voltage levels. The vertical part of the wave represents an "instantaneous" transition from one level to the other. In A the waveform switches from zero to +10 volts and back. The 0 to +10 transition is called the leading edge while the +10 to 0 transition is known as the trailing edge. Note that the wave has two parts, "on" when +10 volts is present and "off" when the wave is zero. The "on" parts of the waveform are usually referred to as pulses.

In B, the pulses ride on a fixed 1-volt DC plateau. The pulses switch between 1 volt and 6 volts. Even though the waveform is never actually "off" because of the 1-volt level, the pulses are still called the "on" part while the 1-volt level is said to be "off."

In Fig. 1C, the rectangular wave is AC because it changes polarity as it switches between +5 and -5 volt levels.

The waveform at D is DC, but it switches between two negative voltage levels, -0.8 and -5.2 volts.

Amplitude

The voltage amplitude of a pulse (V_a) is the amount of

voltage between the two voltage levels. It is the difference between the maximum or positive voltage (V_{max}) and minimum or negative (V_{min}) voltage levels:

$$V_a = V_{max} - V_{min}$$

We compute the pulse amplitudes of the waveforms in Fig. 1 as follows:

- A: $V_a = 10 - 0 = 10$ volts
 B: $V_a = 6 - 1 = 5$ volts
 C: $V_a = 5 - (-5) = 5 + 5 = 10$ volts
 D: $V_a = -0.8 - (-5.2) = -0.8 + 5.2 = 4.4$ volts

Using sinewave terminology, the pulse amplitude can also be called the peak-to-peak voltage. Whatever you call it, it is the voltage you will measure on an oscilloscope.

Rise and Fall

In reality, pulses don't switch instantaneously from one level to another. It takes a finite period of time for the voltage to rise or fall. The transition times are usually short compared to the pulse duration, but they are measurable. They are referred to as the rise and fall times. Fig. 2 shows what a real pulse would look like on an oscilloscope.

The rise and fall times are measured between the 10% and 90% amplitude points on the waveform. See Figure 2. The rise time (t_r) is the time it takes for the leading edge to increase from 10% of the pulse amplitude to 90% of the pulse amplitude. If the total pulse amplitude V_a is 12 volts, you would measure the rise time between these two levels:

$$\begin{aligned} 10\%: 12 \times .1 &= 1.2 \text{ volts} \\ 90\%: 12 \times .9 &= 10.8 \text{ volts} \end{aligned}$$

The fall time (t_f) is the time it takes for the trailing edge to drop from 90% to 10% of the pulse amplitude. Typical pulse rise and fall times are in the nanosecond and low-microsecond range.

Pulse Duration

The time that the pulse is "on" is called the pulse duration or pulse width. Since it is a time measured in seconds, we label it with a "t":

$$\text{pulse width} = t_d$$

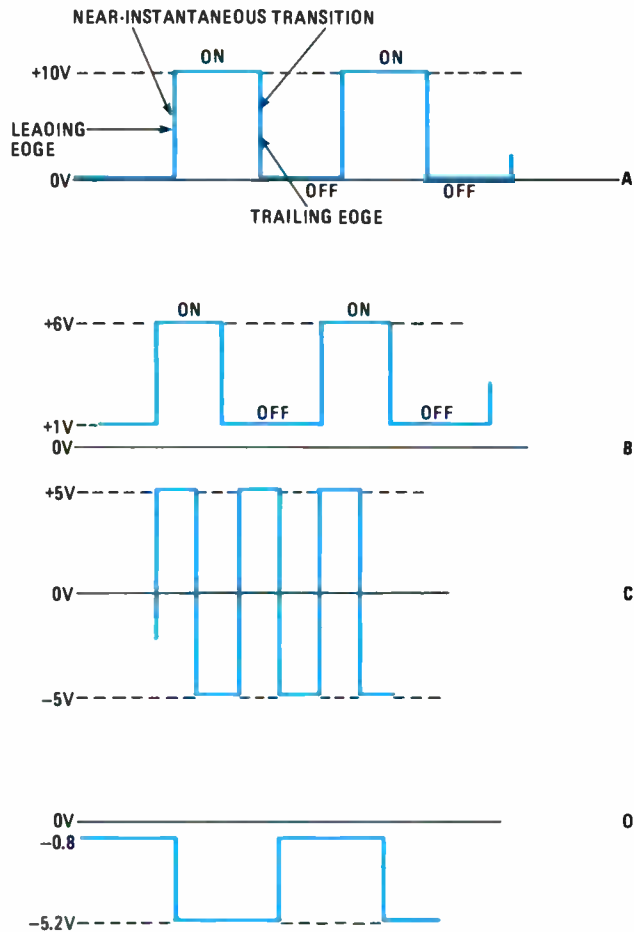

Fig. 1—In A, the waveform switches from zero to +10 volts and back, so the amplitude is 10 volts. In B, the pulses are accompanied by a DC component. A waveform of equal amplitude, but without the DC component, would have a lower average value. In C, the rectangular wave has a zero average value since it's symmetrical. The waveform in D is DC, but it switches between two negative voltage levels, -0.8 and -5.2 volts, giving it a negative average value.

The "d" stands for duration. The pulse width is usually measured between the 50% amplitude points on the leading and trailing edges as shown in Fig. 2. If the pulse amplitude is 12 volts, you would measure the pulse width between the 6-volt amplitude points as shown. That measurement would be done on an oscilloscope.

Most rectangular waves are periodic; that is, the pulses repeat at fixed regular intervals. Because of that, pulses have a frequency. The frequency is the number of pulses occurring in one second. You will often see pulse frequency expressed as pulses per second (denoted pps). Pulse frequency is also called the pulse repetition rate (represented by prr) or pulse repetition frequency (written prf). It is often expressed in hertz (or Hz, as always) as well as pps.

The frequency, of course, is related to the period of the pulse waveform. As in a sinewave, the period is the time for one cycle. In pulse terms, one cycle is one "on" pulse and one "off" interval between pulses as Fig. 3 illustrates. You can measure the period between successive leading or trailing edges as shown.

The period and frequency are related as they are on sine-waves:

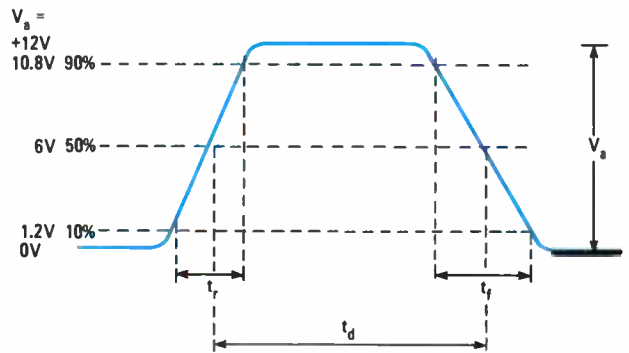

Fig. 2—Since it takes time for components to respond, no squarewave is truly square. Two characteristics indicating how square such a wave may be are the rise and fall times.

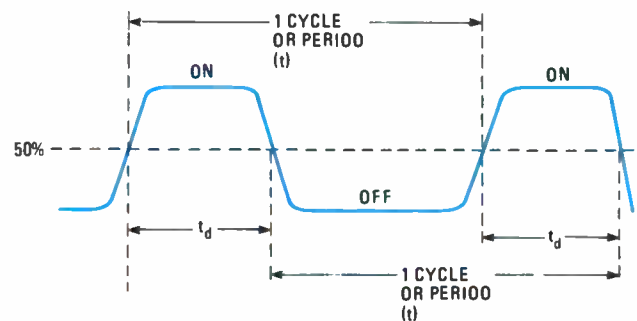

Fig. 3—The duty cycle is nothing more than a ratio between on time and the total period of a wave. The time periods are measured between points at 50% of the desired value.

$$t = 1/f = 1/\text{prf}$$

$$f = \text{prf} = 1/t$$

If the period is 125 μs , the frequency is:

$$f = 1/125 \times 10^{-6} = 8000 \text{ pps or } 8 \text{ kHz}$$

A pulse repetition frequency of 4 MHz produces a period of:

$$t = 1/(4 \times 10^6) = .25 \text{ microsecond or } 250 \text{ nanoseconds}$$

Duty Cycle

Unlike sinewaves, pulse waveforms have an interesting characteristic in that their "on" and "off" intervals may be unequal. In a sinewave, the positive and negative half cycles usually have equal amplitudes and durations. Pulses have virtually any "on-off" time relationship.

One way to express that "on-off" relationship is known as the duty cycle. The duty cycle (D) is the ratio of the pulse duration or width (t_d), that is the "on" time, to the period (t). Duty cycle is usually expressed as a percentage:

$$D = (t_d \times 100)/t$$

What the duty cycle tells is the percentage of the cycle that the pulse is "on."

If a rectangular wave has a frequency of 200 kHz and a pulse width of 1 μs , what is the duty cycle? Start by calculating the period:

$$t = 1/f = 1/200 \times 10^3$$

$$t = 5 \mu\text{s}$$

The duty cycle then is:

$$D = (1 \times 100)/5$$

$$D = 100/5 = 20\%$$

That means that for 20% of the cycle, the pulse is "on."

The duty cycle can range from less than one percent for very-narrow pulses to over 90% for very-wide pulses. A rectangular wave with a 50% duty cycle—with equal "on" and "off" times—is called a squarewave. On most waveforms, the duty cycle is fixed. But it is possible to vary it—to modulate the pulse width. Doing so is called pulse-width modulation (or PWM) which is widely used in telemetry, motor control, and switching power-supply regulators.

Average Values

While all of the previously mentioned pulse characteristics are normally measured on an oscilloscope, there are times when it is convenient or necessary to measure pulse amplitude with an ordinary analog or digital multimeter. Recall that a multimeter reads the effective or rms value of a sinewave. There is no such thing as an rms value in a pulsed waveform. Instead, a multimeter measures an average value of voltage. That average value V_{avg} can be computed with the formula:

$$V_{avg} = V_b + V_a(D)$$

V_b is the baseline voltage or DC component. V_a is the pulse amplitude as defined earlier. D is the duty cycle expressed as a fraction. Let's show some examples using the waveforms from Fig. 1.

In Fig. 1A, there is no baseline voltage. If we assume a duty cycle of 50% or .5, the average voltage is:

$$V_{avg} = V_b - V_a(D)$$

$$= 0 + 10(.5) = 5 \text{ volts}$$

In Figure 1B, assume a duty cycle of 40% or .4:

$$V_{avg} = V_b - V_a(D)$$

$$= 1 + 5(.4) = 1 + 2 = 3 \text{ volts}$$

For the waveform in Fig. 1C, we could say that the baseline or DC component is -5 volts. The pulse amplitude, as determined earlier, is 10 volts. If the duty cycle is 50%, the average voltage is:

$$V_{avg} = V_b - V_a(D)$$

$$= -5 + 10(.5) = -5 + 5 = 0 \text{ volts}$$

An asymmetrical squarewave has a zero average because it spends an equal amount of time above and below zero.

Finally, assume the duty cycle of the wave in Fig. 1D is 65%. The DC component is -0.8 and the amplitude we computed before is 4.4 volts, but it is a negative voltage:

$$V_{avg} = V_b - V_a(D)$$

$$= -0.8 + (-4.4)(.65)$$

$$= -0.8 + (-2.86) = -3.66 \text{ volts}$$

Exercise Problems

It's time to see if you can do such calculations. To check what you have learned, work the problems below.

1. Refer to Fig. 4. What is the rise time for a vertical scale of 1 volt/division and a horizontal scale of 50 ns/division?
2. A pulse waveform has a frequency of 10 kHz and a pulse width of 80 μ s. What is the duty cycle?
3. A squarewave has an "off" time of 60 ns. What is the pulse duration? The prf ?
4. A pulse signal has an amplitude of +4 volts riding on a

+0.3-volt DC level. The duty cycle is 55%. What voltage would you expect to measure on a DC multimeter?

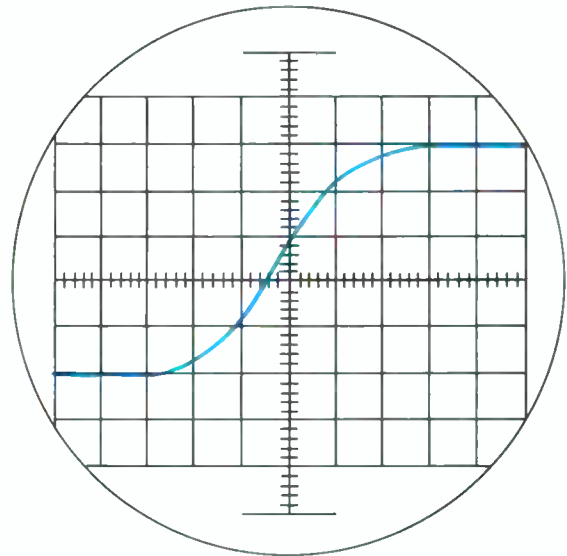

Fig. 4

Analysis Techniques

There are two basic ways to analyze circuits using pulses. One method is the transient-response method. It analyzes the response of a circuit over time. For that method, we determine just how the input and output signals vary with time. A number of mathematical techniques allow you to calculate the exact voltage output over time. You saw an example of that in last month's installment where you saw how to compute the output voltages of RC differentiator and integrator circuits with pulse inputs.

Another technique used to help analyze the response of circuits to input pulses, is known as the frequency-response method. The frequency-response method is based on the Fourier theorem. The Fourier theorem states that any nonsinusoidal waveform, such as squarewaves, pulses, sawtooths, or whatever, can be represented by a series of harmonically related sinewaves plus a DC voltage. The theorem was developed by a French physicist named Joseph Fourier. He developed the mathematical techniques which allow a given nonsinusoidal waveform to be expressed in terms of a number of related sinewaves. The mathematical expression composed of sinewaves with different frequencies and amplitudes added together is known as a Fourier series.

Fourier Theory

What the Fourier theorem really says is that any nonsinusoidal wave can be constructed by algebraically adding together sinewaves of correct frequency, phase, and amplitude. The sinewaves to be added together are harmonically related. A harmonic is a sinewave whose frequency is some integer multiple of a *fundamental* frequency. The fundamental frequency will turn out to be the same as the pulse frequency. For example, a 100 Hz sinewave might be the fundamental of some waveform. The second harmonic is a sinewave of twice that frequency, or 200 Hz. The third harmonic is a sinewave three times the fundamental, or 300 Hz, and so on.

The most often used example in explaining the Fourier

theory is to show how a squarewave can be constructed by adding together various harmonically related sinewaves. Figure 5 shows one way it might be done. Multiple sinewave generators are connected in series so that their outputs are added algebraically. The resulting output is shown in Fig. 6. A squarewave is composed of a fundamental sinewave whose frequency is the same as that of the squarewave. To that is added an infinite number of *odd* harmonics. A squarewave does not contain any even harmonics. To form a squarewave, the third, fifth, and so on harmonics are added together as shown in Fig. 6. As you can see, as each additional higher harmonic is added, the composite waveform more closely approximates the squarewave.

Breaking Down a Wave

Fourier described a technique that permits you to accurately determine the exact harmonic content of any non-sinusoidal wave. The result is a Fourier series which is nothing more than a mathematical expression containing the various sinewaves involved. It is not necessary for you to know how to compute a Fourier series. However, the Fourier series expression is relatively simple to understand. Below is the Fourier series expression for an AC squarewave:

$$v = \pi/4[\text{Sin } \omega t + \frac{1}{3}(\text{Sin}3\omega t) + \frac{1}{5}(\text{Sin}5\omega t) + \frac{1}{7}(\text{Sin}7\omega t) + \frac{1}{9}(\text{Sin}9\omega t) + \dots]$$

The first term represents the fundamental sinewave. The second term represents the third harmonic, while the following terms represent the fifth, seventh and ninth harmonics.

There are several important things to note in that expression. First, the frequency term in each sinewave (ω) is multiplied by a factor equal to the integer harmonic value. You can quickly see which terms of the series represents which harmonic.

Second, note that the factor written ahead of each term is also dependent upon the harmonic value. For example, the fifth harmonic has a peak amplitude one-fifth of the fundamental amplitude.

If the squarewave has a DC component, a voltage of that value, either positive or negative, would be added to the expression above. If the squarewave rides on a 7-volt DC component, 7 would be added to the Fourier series.

Line-Spectra Graphs

Another method of illustrating the harmonic content of a nonsinusoidal wave is to use a line-spectra chart. Such a chart plots the amplitudes of the various sinewaves versus frequency. Figure 7 shows the frequency-spectrum chart for the squarewave. The large line on the left represents the peak amplitude of the fundamental sinewave. The remaining vertical lines represent the peak amplitudes of the third, fifth, seventh, ninth, etc., harmonic sinewaves. That is the waveform that would be displayed on a spectrum analyzer. A spectrum analyzer is an oscilloscope-like device that breaks a signal applied to it down into its harmonic frequencies and then displays them as a frequency-spectrum graph on a CRT display.

The Fourier series for other nonsinusoidal waveforms vary considerably depending upon their specific shape. For example, a rectangular wave without a 50% duty cycle usually contains all harmonics, both odd and even. The actual harmonic amplitudes depend upon the duty cycle of a particular waveform.

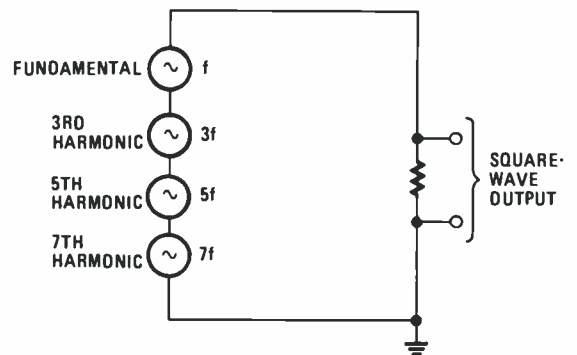

Fig. 5—This circuit would effectively produce a waveform that is the algebraic sum of the four generators. Since the sinewaves the generators produce are harmonics, if their signals have the proper amplitudes and same phase, the output wave would be an approximate squarewave.

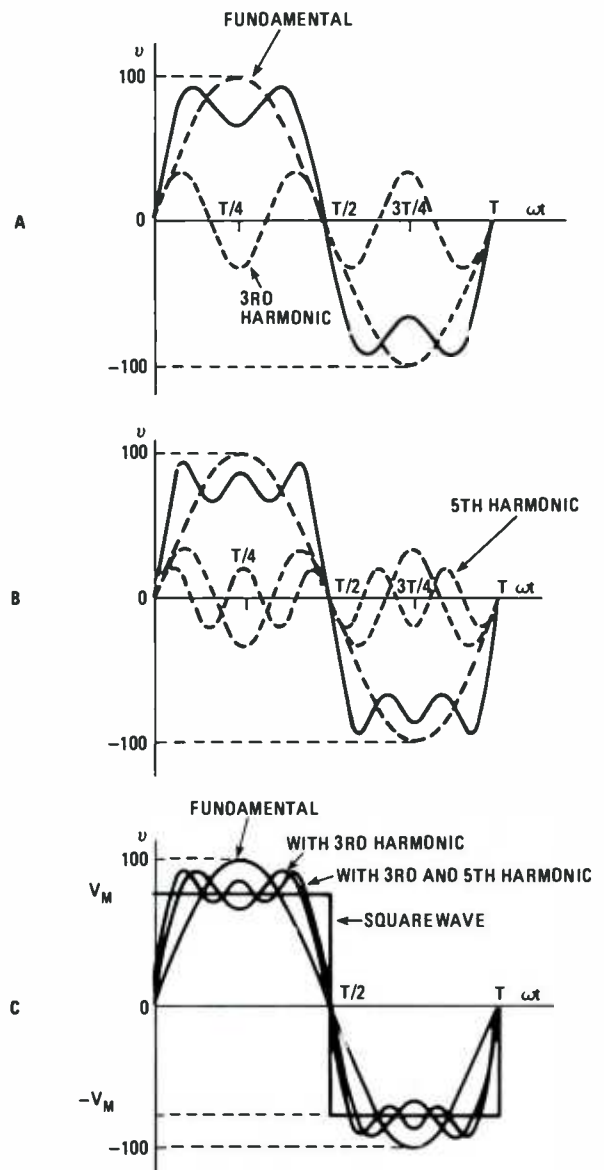

Fig. 6—As you can see in A, adding the fundamental and third harmonic flattens out the sinewave peak. As you add successive harmonics, as in B, the wave flattens further, and the higher-frequency waves fill in the corners.

The Sawtooth

Another example is a sawtooth wave. A sawtooth wave consists of a linear ramp of voltage followed by a sharp vertical transition as illustrated in Fig. 8. Such a waveform consists of a fundamental plus all odd and even harmonics. As in any such waveform, the greater the number of harmonics added together, the closer the waveform approximates the ideal. In the figure, the expressions indicate the sum of the harmonics. For example, $S_3 = 1 + 2 + 3$ means the sum of the

fundamental (the number 1) plus the second and third harmonics.

The mathematical expression or Fourier series for the sawtooth wave is:

$$v = 2/\pi[\text{Sin}\omega t - 1/2(\text{Sin}2\omega t) + 1/3(\text{Sin}3\omega t) - 1/4(\text{Sin}4\omega t) + 1/5(\text{Sin}5\omega t) - 1/6(\text{Sin}6\omega t) + \dots]$$

The negative sign on every other term means the harmonic is inverted or 180° out of phase with its usual position.

A triangular wave is shown in Fig. 9. Its Fourier series is:

$$v = 8/\pi^2[\text{Sin}\omega t - 1/9(\text{Sin}3\omega t) + 1/25(\text{Sin}5\omega t) - 1/81(\text{Sin}7\omega t) + \dots]$$

Note here that only odd harmonics are indicated. Second, the amplitudes of the harmonics are very small.

Halfwave Breakdown

Figure 10 shows the output of a typical fullwave rectifier. It consists of a series of half-sine pulses. Even though those pulses are sinusoidal in shape, they do not form a sinewave. Because of that, the resulting complex wave also contains harmonics. Its Fourier expression is:

$$v = 2/\pi + (4/\pi)[1/3(\text{Cos}2\omega t) + 1/15(\text{Cos}4\omega t) + 1/35(\text{Cos}6\omega t) + \dots]$$

There are several important facts about that expression. First, the cosine is used instead of the sine. A cosinewave is exactly

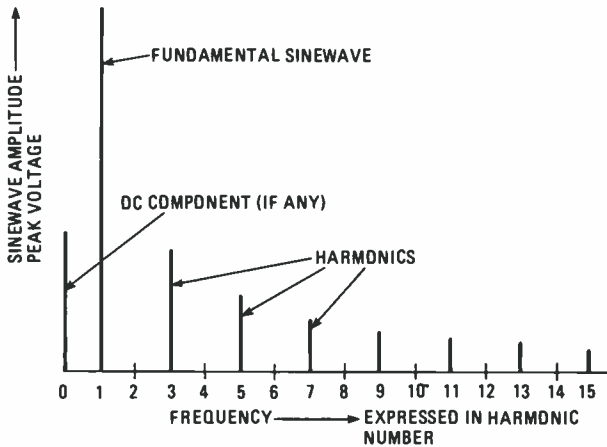

Fig. 7—Comparing the relative amplitude of harmonics in a wave can best be done using a line-spectra chart. Note the decrease in amplitude with increasing frequency.

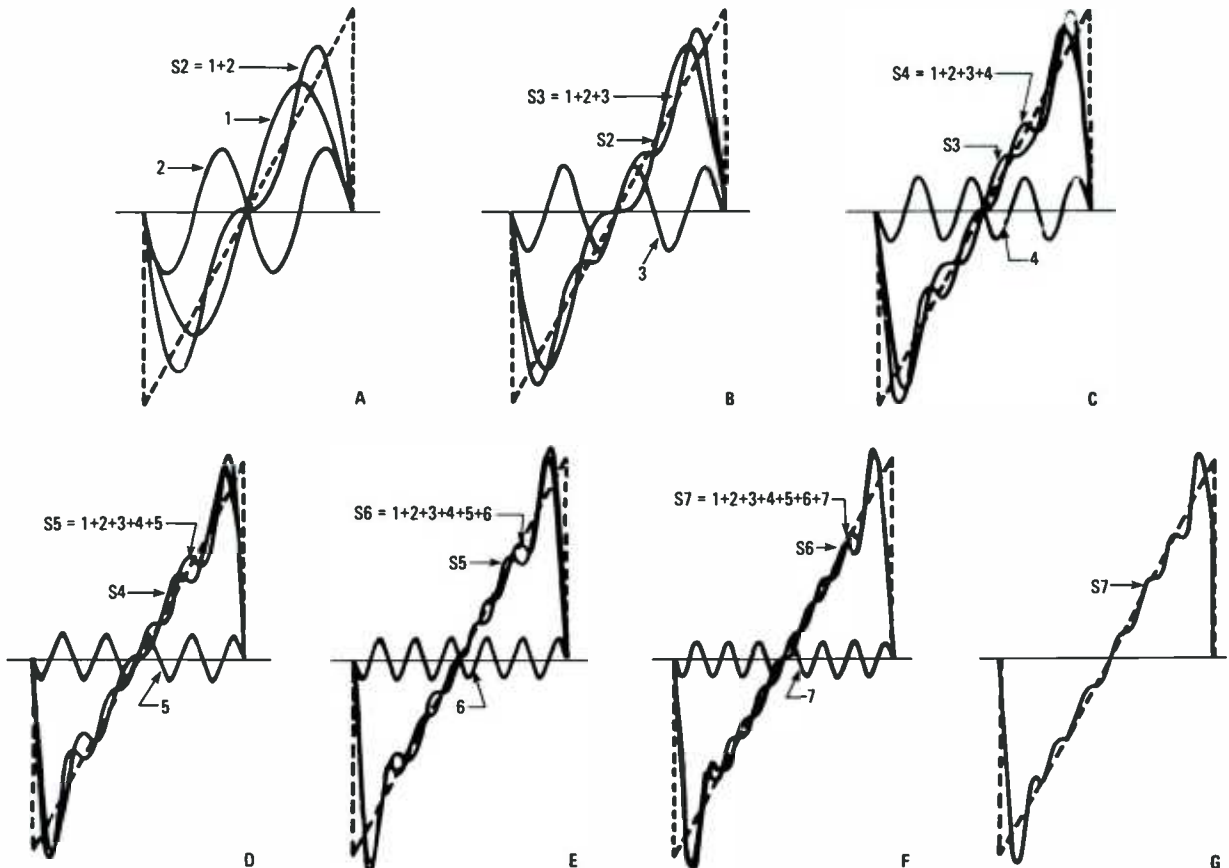

Fig. 8—Even triangle waves such as this one can be assembled using a sum of harmonics. Notice how accurate the model gets just by adding up to the seventh harmonic.

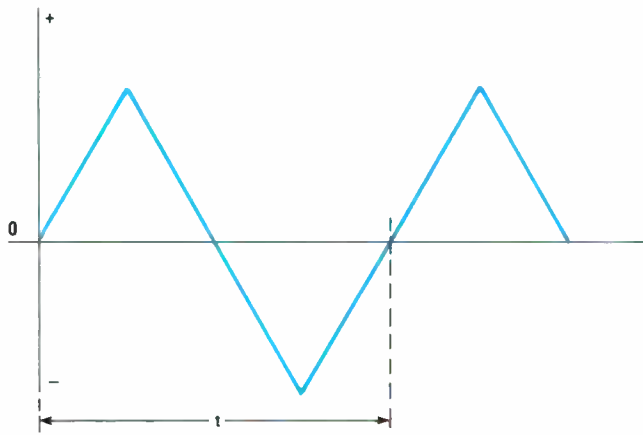

Fig. 9—Yes, even the triangle wave falls prey to the Fourier series. However, the harmonics' amplitudes are small because the fundamental really makes up most of the waveform, which is why it looks a little like a sinewave.

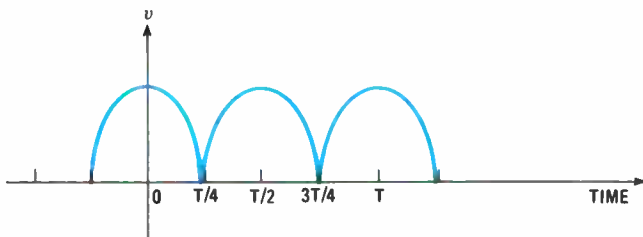

Fig. 10—Like its straight-line cousins, the half sine wave output from a fullwave bridge rectifier can be represented by a Fourier series with a fundamental frequency equal to double the frequency of the original sinewave.

the same as a sinewave except that it is shifted in phase (leading) by 90 degrees.

Second, there is no fundamental wave, because the expression lacks a $\text{Cos}\omega t$ term. Also note that only even harmonics are present.

Finally, the wave contains a DC component, in this case $2/\pi$. A number of reference books are available listing the Fourier series for all of the most widely used nonsinusoidal waveforms. Integral calculus techniques for generating the Fourier series' would have to be used for any special waveform.

Using the Fourier Theory

The Fourier theory explains a lot of things in electronics. In your analysis of circuits and in your general understanding of how circuits process signals, the Fourier theory clears up a lot of confusion. For example, as a general statement we can say that any time that we generate a nonsinusoidal signal we, in effect, generate a fundamental sinewave and many harmonics. When you look at pulse signals, sawtooths, half sine-waves, or whatever, try not to visualize just the nonsinusoidal waveform, but instead visualize many harmonically related sinewaves, all added together. With that view, you can then often see what is happening inside a circuit that is processing the nonsinusoidal wave.

Amplifier Distortion

A good example of that is how an amplifier can introduce distortion to a signal. Assume that we have a simple audio amplifier like that shown in Fig. 11. That is a common-emitter

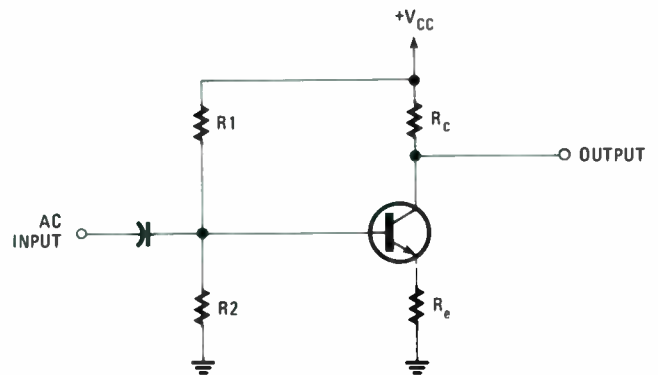

Fig. 11—A basic common-emitter amplifier, such as this one, can be overdriven by completely biasing the transistor.

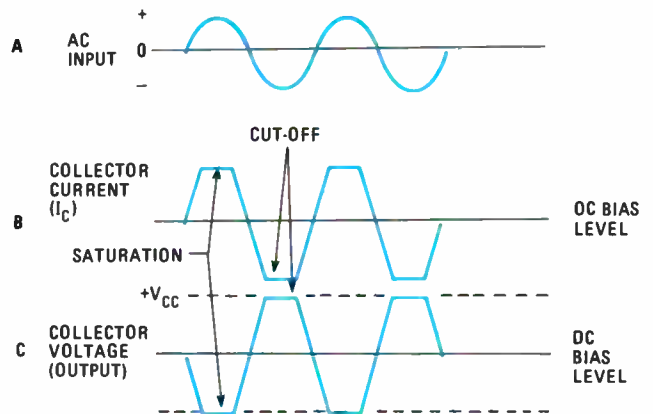

Fig. 12—If an input signal without noise, as in A, provides a bias current (B) too great for the circuit to reproduce, then clipping noise (C) will be the result.

voltage amplifier. Assume that we are using it to amplify a voice signal from a microphone or music. If the transistor amplifier is not biased correctly, or if the input signal operates at too high a level, the circuit will introduce distortion. Distortion results in the generation of harmonics of the signal being amplified.

To simplify the discussion, assume that we are amplifying a sinewave. Assume further that the sinewave is extra high in amplitude. That may be caused by an excessively high input signal, or may be caused by simply setting the volume control too high. The result is that the signal overdrives the amplifier introducing distortion in the signal. The waveforms in Fig. 12 show how that happens.

Circuit Operation

On the positive halfcycle of the input, the transistor base current is increased. That causes the collector current to increase in turn. As the collector current increases, more voltage is dropped across the collector resistor R_c and less across the transistor and emitter-resistor R_e . With those conditions, an increasing input voltage produces a decreasing output voltage. The result is an amplified output signal that is the inverse of the input signal. That is the normal operating condition.

On the negative halfcycle, the input voltage causes the base current to decrease. A decrease in base current causes the collector current to decrease. That reduces the voltage across the collector resistor and increases the output voltage.

Clipping the Waveform

If the input signal is very large, it will cause the transistor to saturate and cut off on alternate half cycles. The result will be distortion. On the positive half cycle, the high input signal drives the transistor into saturation. That causes the transistor to conduct very hard and to essentially become a short circuit. The output voltage drops to a level determined by the collector and emitter resistors or about:

$$V_{cc}(R_e/R_c + R_e)$$

The output voltage is flattened during the positive half cycle.

During the negative half cycle of the input signal, the base current actually drops to zero. The collector current cuts off. With no current through the collector resistor, there is no voltage drop across it. Therefore, the output voltage is simply the supply voltage V_{cc} . That causes the signal to be flattened on the top. The resulting output signal, as you can see in Fig. 12, is simply a sinewave that has the positive and negative peaks clipped off.

Clipping Effects

The shape of the output signal approaches that of a square-wave. Therefore, obviously it must contain a considerable number of harmonics. Instead of hearing a pure sinewave tone in the output, what you actually hear is the fundamental sinewave tone to which has been added many higher-frequency harmonics. So while the basic pitch of the sound will be the same, it will appear distorted or "colored" making it sound like something other than a pure sinewave tone.

When voice or music is amplified, the effect is the same only more so. Voice or music is made up of multiple frequency signals to begin with. When they are distorted, harmonics are generated for each of the frequencies in the signal. You can see why distortion causes the voice or music to sound like something other than the original. The distortion may be so bad as to make the voice totally unintelligible. Music, of course, wouldn't sound anything like the original.

Generating Distortion

While distortion is usually undesirable, sometimes we deliberately distort a signal for the purpose of producing harmonics. That is exactly what we do in a circuit called a frequency multiplier. A frequency multiplier is a circuit that generates an output signal that is some integer multiple of the input signal. There are many applications where we wish to increase the frequency of the signal by some whole-number value. A common application is in radio transmitters where a low-frequency crystal oscillator generates a signal whose frequency is increased with frequency multipliers to obtain a higher radio-frequency output.

Frequency Multipliers

A frequency multiplier is basically an amplifier circuit that distorts the input signal. In radio transmitters, the input signal is usually a sinewave. The frequency multiplier is a class-C amplifier circuit. The class-C amplifier circuit is biased beyond cut off and, therefore, will conduct only on the positive halfcycles of the input signal.

A basic class-C amplifier is shown in Fig. 13. The negative voltage applied to the base resistor keeps the transistor cut off. During the positive halfcycle, the input signal overcomes the bias, causing the resistor to conduct. The collector current, therefore, comes in short pulses as illustrated in Fig. 13. Those are not half-sinewave pulses as they are actually shorter

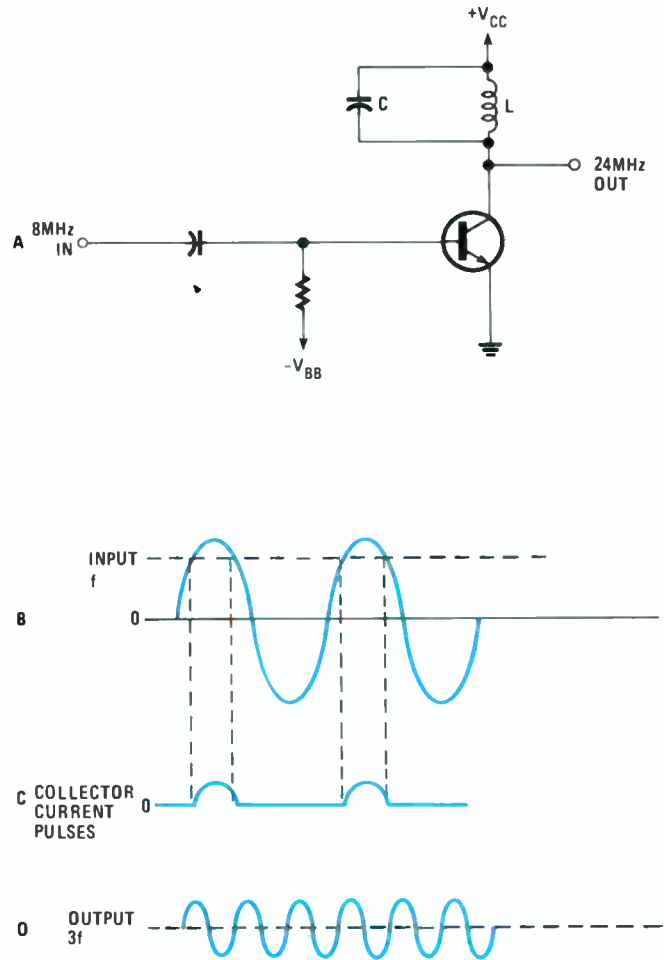

Fig. 13—A class-C amplifier can be used to trigger a tank circuit which effectively filters out the third harmonic.

than one-half cycle of the input signal, as you can see. Those pulses actually contain both odd and even harmonics.

The desired harmonic is then selected with a resonant circuit. The resonant frequency of the parallel tank circuit connected to the collector is adjusted with the values of L and C to the desired harmonic. For example, if the input signal is 8 megahertz and we want a frequency multiplication of 3, then the tuned circuit in the collector must be resonated at:

$$3 \times 8 = 24 \text{ MHz}$$

A Fourier analysis of the output pulse tells us that the signal contains the third harmonic. Therefore, we use the parallel resonant circuit as a filter to select it for the output, while rejecting the fundamental and all of the higher harmonics. That concept of distorting a signal to produce harmonics and then using a selective filter to choose one of the desired higher harmonics, is widely used in many different areas of electronics.

Bandwidth Tests

Another useful application of the Fourier theory is in squarewave testing. Squarewaves can be applied to amplifiers and other linear circuits for the purpose of determining their frequency response. The frequency response of an amplifier defines the range of frequencies over which it will amplify.

A typical frequency-response curve might appear like that shown in Fig. 14. The amplification occurs in that broad flat mid-range area. But as the frequency decreases, at some

point the output gain will begin to decrease or roll off. At some point in the higher frequencies, the gain will also decrease and roll off considerably. The frequencies at which the roll offs begin are known as the cut-off frequencies. In the example shown, the amplifier has a lower cut-off frequency of 100 Hz and an upper cut-off frequency of 6 kHz. The cut-off frequencies really define the lowest and highest frequencies the amplifier can reproduce well.

Data Generation

One way to obtain that curve is simply to plot it. A sinewave signal generator is applied to the input of the amplifier and the frequency is varied over the desired range. The output voltage at each of the input frequencies is then recorded and then plotted to form the curve.

Another quick way to test an amplifier and get a rough approximation of its frequency response is to test it with a 1 kHz squarewave. When we apply a squarewave to the input of the amplifier, remember that we are actually applying a fundamental sinewave and an infinite number of odd harmonics. The amplifier will act as a filter and will, of course, remove some of those harmonics. The output of the amplifier, therefore, will not be a squarewave. The actual shape of the output will depend upon just how many of the harmonics are removed.

The Output

Using the amplifier described above, we know that its upper cut-off frequency is 6 kHz. Therefore, all harmonics higher than 6 kHz will be greatly attenuated or filtered out. With a 1-kHz squarewave input, we will also be applying harmonic sinewaves of 3 kHz, 5 kHz, 7 kHz, 9 kHz, and beyond. In this case, only the 3-kHz and 5-kHz harmonics will be passed. The 7th, 9th, and higher harmonics will be effectively removed from the output. The result will be an output waveform that looks something like the one that is shown in Fig. 15.

The output signal only approximates a squarewave. The rise and fall times are lengthened considerably. The amplifier distorts the squarewave because it filters out the higher harmonics. That is known as frequency distortion. It is different from the kind of distortion discussed earlier which causes a signal to be clipped and harmonics to be generated. In frequency distortion, upper harmonics are usually eliminated, thereby distorting a nonsinusoidal signal.

The effect of filtering out the higher harmonics is to cause the waveform to be rounded. The rise and fall times get longer. That means that it is the higher harmonics that produce the short rise and fall times in a signal and, therefore, the steep sides of a squarewave. Eliminating those higher harmonics causes a rounding of the waveform and increases the rise and fall times. By observing the input and output signals with a squarewave input, you can get a pretty clear indication of just what the circuit is doing.

Upper Cut-Off Frequency

All amplifiers have an upper cut-off frequency. Amplifiers essentially act as low-pass filters that pass all frequencies up to the upper cut-off frequency. Some amplifiers have a wider bandwidth than others.

For example, if we applied our 1-kHz squarewave to an amplifier whose upper cut-off frequency was approximately 100 kHz, the circuit would actually pass signals up to the 99th harmonic. Obviously, with all those harmonics being passed,

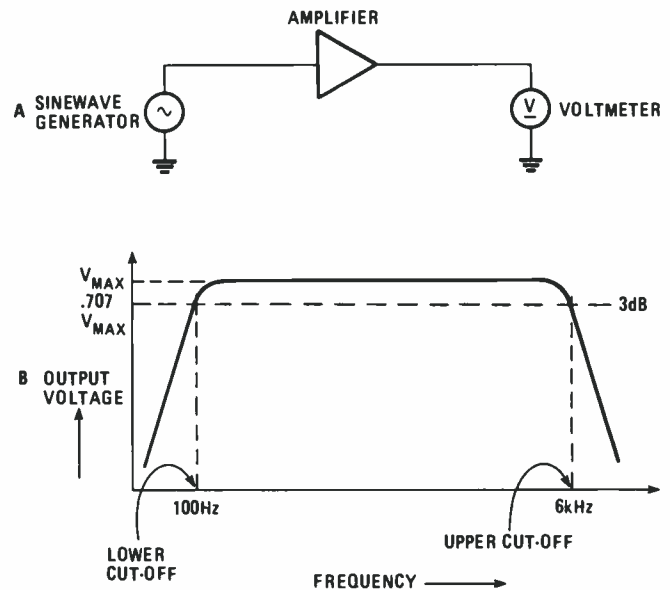

Fig. 14—The bandwidth of any amplifier (A) is the frequency range over which it can operate with a loss of no more than 3 db (that is $.707 \times V_{max}$).

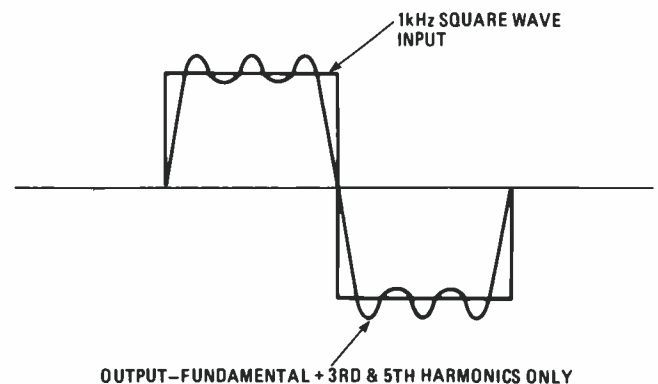

Fig. 15—A good test of an amplifier's bandwidth is to supply it with a squarewave to see what harmonics pass through it unscathed. The output will be a sum of harmonics.

the output signal will essentially still be a near perfect squarewave. Therefore, the wider the bandwidth, the more faithfully an amplifier will reproduce the nonsinusoidal signal input.

You can actually get a very accurate indication of the upper cut-off frequency of an amplifier by measuring the rise time of the squarewave at the amplifier output. The rise time of the output signal is related to the upper cut-off frequency by the expression:

$$f = .35/t_r$$

That expression says that the upper cut-off frequency in megahertz (f) is equal to $.35$ divided by the rise time of the output squarewave given in microseconds. It is important to keep in mind that that is the rise time of the output signal only, *not* the rise time of the input signal, which is assumed to be negligible.

As an example, let us assume that the rise time of the output of a particular amplifier is 0.5 microseconds or 500 nanoseconds. Therefore the upper cut-off frequency of the amplifier can be found from:

$$f = .35/.5 = .7 \text{ MHz or } 700 \text{ kHz}$$

Scope Applications

The relationship discussed in the previous section is widely used in stating the frequency response of the vertical deflection amplifier in an oscilloscope. When reading the specifications of a scope, in nearly every case you will see a figure for rise time given. The actual upper cut-off frequency of the oscilloscope amplifier can easily be determined by using that formula. With a rise time of 5 ns (.005 μs), the upper cut-off is:

$$f = .35/.005 = 70 \text{ MHz}$$

You can also rewrite the formula to compute the rise time for a given upper-frequency response. When that is done, the formula is:

$$t_r = .35/f$$

In that case, assume that we have an oscilloscope with an upper cut-off frequency of 35 megahertz. We can compute the fastest rise time that the scope can display by using the formula:

$$t_r = .35/35$$

With a bandwidth that wide, the oscilloscope will faithfully reproduce squarewaves with a rise time as short as .01 microseconds or 10 nanoseconds.

If the input signal has a faster rise time than that, the signal simply will not be "seen" by the oscilloscope. That is because the amplifier rolls off at 35 MHz, thereby eliminating the higher-frequency harmonics that would produce a faster rise time.

Upper Cut Off Frequency

You can also use that formula for quickly determining the upper-frequency response of an amplifier. Simply apply an extremely fast rise-time squarewave to the amplifier input as we described earlier in squarewave testing. Then, connect an oscilloscope to the output and measure the rise time. Take that rise-time figure and, using the above formula, it should be possible to calculate the upper cut-off frequency of the amplifier in question.

Another Method

If the rise time of the test signal and the scope is very much faster than the rise time of the amplifier, then the formula can be used as is.

However, if the rise time of the input signal is on the same order of magnitude as the rise time of the amplifier and scope, you need to modify the expression. The formula that follows shows the expression for calculating the actual amplifier rise time (t_a) if the scope rise time (t_s) and the test input-signal rise time (t_i) are known. The observed rise time, t_r , is approximately equal to:

$$t_a = \sqrt{t_r^2 - t_s^2 - t_i^2}$$

Assume the rise time measured on the scope is 30 ns. The rise time of the input signal is 8 ns and the scope rise time is 10 ns. The rise time of the amplifier under test can be calculated as follows:

$$t_a = \sqrt{30^2 - 10^2 - 8^2}$$

$$t_a = \sqrt{900 - 100 - 64} = \sqrt{736} = 27 \text{ ns}$$

That puts the upper cut-off frequency of the amplifier at about:

$$f = .35/t_a = .35/.027 = 12.96 \text{ MHz}$$

or about 13 MHz.

Practice Problems

5. An oscilloscope has an amplifier bandwidth of 60 MHz. What is the fastest pulse rise time that the oscilloscope can display?

6. An amplifier is tested by applying a squarewave and measuring the output rise time on a scope. The rise time is 1.6 μs. What is the upper cut-off frequency?

2. 80%
3. $t_r = 60 \text{ ns}$, $\text{prf} = 8.33 \text{ MHz}$. In a squarewave, the pulse "on" and "off" times are equal because of their 50% duty cycle.
4. + 2.5 volts average
- $V_{\text{avg}} = V^h + V^l(D)$
- $V_{\text{avg}} = +0.3 + 4(.55)$
- $V_{\text{avg}} = +0.3 + 2.2 = +2.5 \text{ V}$
- $t_r = .35/f$
- $t_r = .35/60 = .005833 \mu\text{s} = 5.833 \text{ ns}$
6. 218.75 kHz
- $f = .35/t_r = .35/1.6$
- $= .21875 \text{ MHz}$ or 218.75 kHz

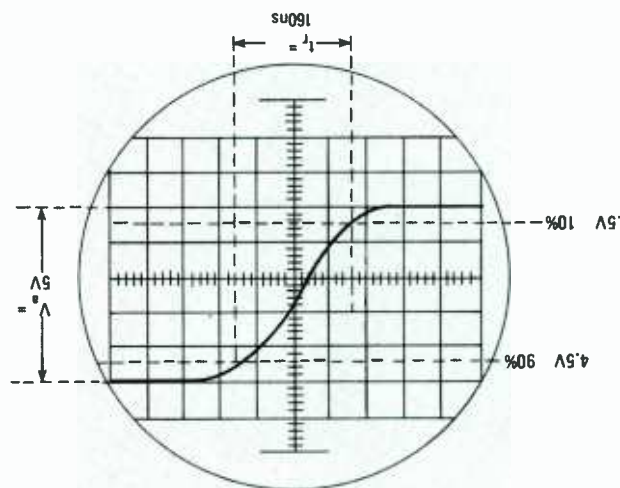

Answers

1. $t_r = 160 \text{ ns}$. See Figure.



ELLIS ON ANTIQUE RADIO

The Zenith Restoration Continues

□ LAST MONTH WE BEGAN THE RESTORATION of a radio with a lot of interesting features, and also a lot of problems. It's a Zenith 7S232 table model "shutter dial" set.

What's a shutter dial? Last month's column contains full details, but if you've just joined us, here's a little background. The shutter dial is an interesting late-1930's Zenith innovation for reducing confusion in tuning multi-band sets. Instead of showing the calibrations for all bands on one multi-scale dial, individual band calibrations are displayed on separate, two-piece circular scales.

The semicircular pieces are connected, scissors-fashion, by a pivoted joint. When a scale is not in use, it is swiveled apart and hidden behind the dial, so that it is no longer visible through the viewing window. That action is controlled by a cam that is associated with the bandswitch, so that the correct scale for the selected band is automatically displayed.

The only calibration that is visible at all times is a circular logging scale around the outer edge of the dial. All markings are beautifully lettered in white on a black background. Smaller scales, showing the settings of the set's volume, tone, and band controls, are located around the periphery of the

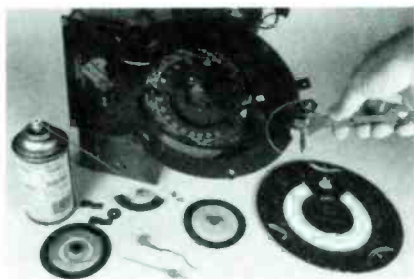

Here we are almost ready for removal of shutter mechanism from the set (which is standing on its side). The large outer bezel is at lower right; the small indicator wheels at lower left are for volume, tone, and band controls.

large circular tuning dial. And to complete the picture, a *magic-eye* tuning indicator is located at the 12-o'clock position. With the dial calibrations softly illuminated by two hidden pilot lights, and the magic-eye tube radiating its green glow, the dial makes a very impressive appearance indeed.

Removing the Shutter

Last month, when we reviewed the set's more obvious problems, I mentioned that the bandswitch and shutter mechanism were jammed. Since I couldn't see all of the dial calibrations, I wasn't even able to report on the radio's frequency coverage. So it seemed like a good idea to begin the restoration by tackling the dial problem.

Normally, disassembly of such a dial would have to begin with removal of the dial glass. But since there is no glass right now (another problem to be solved!), the mechanism was already exposed and ready to be worked on. I decided to proceed carefully and in stages, removing only what I needed in order to free up the shutter-dial assembly so that it could be separated from the set.

Pulling off the long pointer for the set's vernier (or logging) scale, made it possible to remove the dial's large outer bezel. (The bezel—see photos—carries the calibrations for the logging scale and has the windows for the magic-eye tube and the frequency, volume, tone, and band scales.) Once the bezel was out of the way, the indicator dials for the volume, tone, and band controls were accessible.

It wasn't much of a trick to loosen the setscrews holding the dials to their shafts, but sliding them off required patience and cautious use of spray lubricant. (The fit was tight and the shafts were corroded.) I was careful not to get any of the lubricant on the plastic dial scales because I was concerned that they might become defaced.

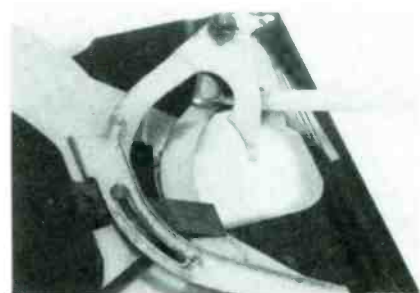

Once the shutter mechanism was removed, it didn't take long to find the problem. The pencil points to buckled metal parts resulting from attempts to clear jammed shutter by forcing the bandswitch.

With those scales out of the way, I removed the second inner-dial pointer (which indicates the frequency calibration shown behind the shutter window). Moving to the other side of the dial mechanism, I slipped the two pilot-light assemblies off their mounting tabs. That left only the tone-control switch to be removed from its location on the dial plate. Once its mounting screws were removed, the shutter-dial assembly was lifted away from the radio with ease.

Unjamming the Dial

Needless to say, I was very anxious to inspect the assembly to see why the dial was jammed. I didn't have to look far to locate the difficulty. One of the shutter-dial segments (see photos) had warped slightly and had jammed against a metal tab in the dial frame. And one of the set's previous owners had attempted to clear the jam by twisting the bandswitch shaft with tremendous force (probably using a pair of pliers). That had the result of twisting and buckling a couple of the dial segment's scissors legs.

Though it looked terrible, the problem was really quite easy to correct. The mechanism was further disassembled, so that both pairs of shutters could be removed, and the buckled legs were straightened by clamping them in a

wise. Luckily, the metal wasn't too springy and didn't resist being flattened again.

With all the shutters removed, I could now finally determine the radio's frequency coverage. One set of shutters is calibrated for the broadcast band (55–170 kHz) and the second one for 5.5–18 MHz. Behind the shutters, normally visible only when both of those scales are pivoted out of the way, is a (fixed) third scale calibrated for 1.98–5.5 MHz. All ranges overlap slightly, giving the receiver continuous coverage from 55 kHz to 18 MHz.

The dial parts (see photos) were then cleaned by gently wiping with a rag dipped in soapy water. (I try to avoid the use of detergents because they have been known to mar delicate finishes, or even remove them.)

Reassembly of the shutter mechanism was quite straightforward, requiring only a little bending here and there to make sure that the shutters would operate without scraping or hanging up. I used a little white lithium grease (left over from an auto-door mechanism problem) at all pivot points.

The Smoke Test Begins!

With the shutter-dial assembly operating smoothly and ready to be reinstalled, I set it aside for the time being and turned my attention to the radio itself. I had already powered up the set with the rectifier tube removed from its socket (see last month's column) and determined that the tubes were lighting and that the power transformer was Okay. Now it was time to fire it up, with the rectifier reinstalled, to see what the radio would do under actual operating conditions.

I began by running the set at reduced line voltage for a while so that the electrolytic capacitors would have every chance to re-form. (See *Ellis on An-*

tique Radio in the May, June, and August, 1987 issues of **Hands-on Electronics** for complete details on the care and feeding of electrolytics.) Since a healthy DC voltage was measured at the output of the rectifier tube and there was no sign of a short circuit, I increased the line voltage to near normal and the speaker came to life.

Because the set's dial drive belt is broken, I had to turn the tuning capacitor by hand to search for stations. Using a short antenna down in my basement workshop, I could only pick up a couple of locals. Though there was no trace of hum—which indicated that the electrolytics were probably Okay—the signals were distorted and accompanied by strong oscillation. Not exactly satisfactory reception, but I was encouraged by the signs of life.

I'm not too concerned about oscillation at this stage of restoration because the squealing could easily be caused by poor ground connections at tube shields and coil enclosures. After the set is cleaned up and corrosion is removed, there's a good chance that the problem will disappear. At any rate, there's no point in troubleshooting it until the cleaning is done. We'll get into repair next month!

G.E. Recreates Classic Radio

Though many replicas of the classic 1930's cathedral radio have appeared on the market, this is the first one (at least that I know of) that is being offered by its original manufacturer. *General Electric* has recreated its 1930 *Model J100* in three-quarter size, and with a few internal improvements (including integrated circuits instead of tubes, an FM band, and internal antennas). Outside, though, the set is all 1930's *ambiance* with its intricately designed, wooden cabinet and traditional glowing dial (see photos).

The price is also scaled down 25% from what it was in 1930; the suggested retail is \$75.00 compared to the original \$99.00. However, G.E.'s press release points out that 99 1930 dollars are equivalent to 817 current ones. That makes the new version (*Model 7-4100J*) quite a bargain when you consider its high-performance chassis and the definitely non-1930's sound quality coming from its 5-inch heavy-magnet speaker. In fact, the set's large speaker and wood cabinet make it probably one of the best-sounding modern table radios.



G.E.'s Model 7-4100J, a recreation of the original Model J100. It's a 1930's set on the outside, but state-of-the-art inside!

Look for the J100 replica at your favorite mass merchandiser, discount store, or catalogue showroom.

A Long-Needed Reference Book

Most collectors of old radios are generally familiar with the names of the major pioneering firms in the broadcast-receiver manufacturing industry. But those of us who'd like to know more about those organizations and the men who put them together usually run into a blank wall. There isn't much information about Bremer-Tully, Clapp-Eastham, Gilfillan, or even Atwater Kent to be found in a library reference room.

Alan Douglas has changed all that with his encyclopedic 3-volume series *Radio Manufacturers of the 1920's*. Volume I (see photos), which covers A-C Dayton through J.B. Ferguson, was released early this year. Future volumes will alphabetically cover manufacturers up to Zenith.

Drawing on contemporary trade publications, popular literature, and manufacturer's brochures, Douglas has used his own 5000-volume reference library and many borrowed resources to piece together an amazingly complete picture. Included for each brand name is a treasure-trove of corporate history, executive biography, advertisements, and promotional literature. Contemporary photographs of surviving radios are also used lavishly. In fact, the author's goal was to come as close as he possibly could to illustrating every model produced during the 1920's.

(Continued on page 100)

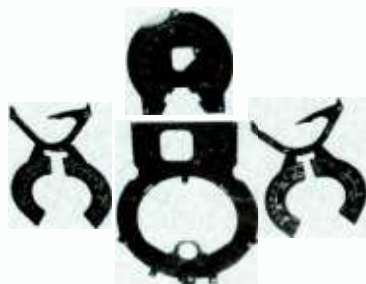

Here the shutter-dial mechanism is shown disassembled. The frame is at top center; the shutters are at left and right; the fixed scale is below them.



By Charles D. Rakes

CIRCUIT CIRCUS

Designing your own power supply

THIS MONTH THE CIRCUS DEALS with obtaining power or, more specifically, how to design and build power supplies for the many circuits that we have shared here in our column, and for future projects.

Many of the projects that we build are designed for portable, and therefore battery, operation. But when it's more desirable to use a particular project in a fixed location, an AC-derived supply is the economical way to go. An AC-derived power supply combined with a battery as a back-up furnishes continuous power to a load even if the AC power is interrupted. Such a dual power-source system offers the best features of both AC and battery operation when uninterrupted service is paramount.

Some circuits require a regulated power source, while others work just fine with simple, unregulated power sources. And as the requirements increase and the tolerances tighten, the cost of the power supply goes up just like a hot-air balloon.

The basic power-supply circuit shown in Fig. 1 can be used to operate most of circuits that do not require a regulated source. If you know the circuit's voltage and current requirements, then building such a power supply is simple. By the way, when selecting a transformer and rectifiers for the circuit, it's always a good idea to increase the current rating of those components over what's required by about 25%, or so. Doing that adds little to the overall

cost of the circuit, and the safety margin offered by the additional current capacity helps to keep *Murphy's Law* at bay.

If a 12-volt, 1-amp supply is needed and a 12-volt transformer is selected, the filtered output would be about 17 volts with no load. Under full load, the voltage drops to between 13 and 15 volts.

Use as much filtering as is possible. A good starting point for C1 is a 5000- μ F, 25-volt electrolytic capacitor. (If you can't find a 5000- μ F capacitor, 4700- or 5600- μ F units, which are readily available, can be used.) The actual value of C1 depends on the level of ripple that the load can tolerate.

Shunt Regulators

The simplest way to regulate the output voltage of the circuit in Fig. 1, is to use a shunt regulator, consisting of a current-limiting resistor and a Zener diode (as shown in Fig. 2), at the output of the circuit. For low output-current demands, that's a workable low-cost solution. However, if the output-current requirement is over 100 mA, that scheme becomes very expensive.

The circuit in Fig. 2 can supply a 12-volt regulated output with a maximum current of 25 mA if the following component values are used: $R_x = 100$ -ohms, 1-watt; D1 = 12-volt, 1/2-watt Zener (like the 1N5242B). For a 9-volt, 25-mA circuit use: $R_x = 200$ -ohms, 1-watt; D1 = 9-volt, 1/2-watt Zener (like the 1N5239B, for instance).

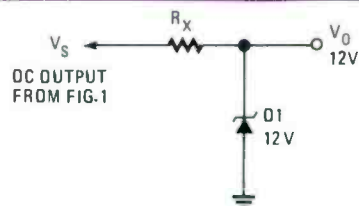

Fig. 2—The simplest way to regulate the output of the circuit in Fig. 1 is to use a shunt regulator (like the one shown here) at the output of the circuit.

For other parameters, it is easy to design an appropriate shunt-regulator circuit by using the following formula:

$$R_x = (V_s - V_o) / I_z$$

where V_s is the unregulated voltage, V_o is the desired regulated output, and I_z is the maximum desired output current. The power dissipation of R_x can be determined by $(V_s - V_o) \times I_z$. If the power dissipation works out to be 0.425 watt, don't try to get by with a 1/2-watt resistor; go to the next-higher standard wattage rating to avoid a burn out. Murphy has been known to raise the input voltage and at the same time double up on the output load to vaporize an under-rated R_x . The added safety factor doesn't cost, it pays.

The needed Zener-diode wattage can be found by multiplying the Zener's rated voltage by the maximum current, or $P = V_z \times I_z$. If the actual wattage works out to be within 25% of a standard Zener-diode's wattage rating, move up to the next higher-rated unit.

Upping the Ante

The shunt regulator shown in Fig. 3 uses a *power-magnifier* circuit to raise the Zener diode's dissipation capabilities. An inexpensive Zener and power transistor are mated to form a "magnum" Zener. If you really want to heat up the works, it's possible to make magnum Zeners that can dissipate over 100 watts.

A power transistor with a gain (H_{fe}) of 50, a collector current of 1 amp, and a

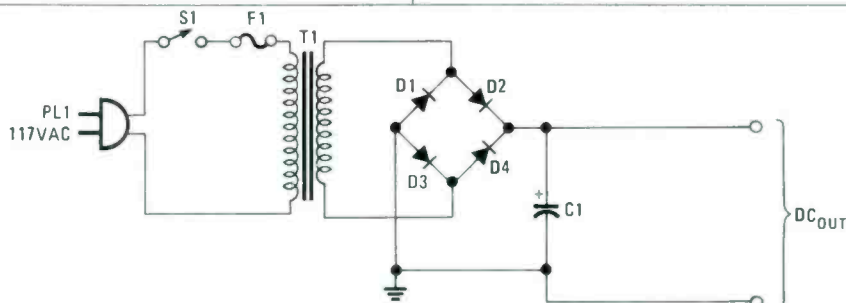

Fig. 1—The basic power-supply circuit shown here can be used to operate the majority of circuits that do not require a regulated-voltage source.

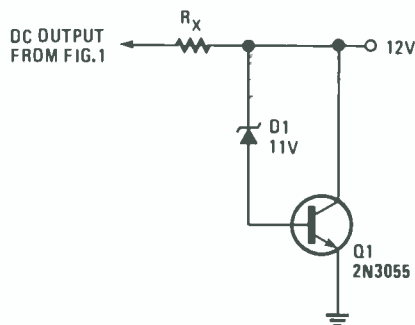

Fig. 3—The shunt regulator shown here uses a power-magnifier circuit to raise the Zener diode's dissipation capabilities. A Zener and power transistor are mated to form a "magnum" Zener.

½-watt Zener together can safely do the work of a 10- to 15-watt Zener. The value of R_x can be found using the formula discussed previously. The actual output voltage will be slightly higher than that of the Zener's rated voltage because of the added base-to-emitter voltage drop of the power transistor. That scheme adds less than 1-volt to the output; and if necessary, that voltage difference can be corrected for by using a Zener with a voltage rating that's slightly less than the desired output voltage.

Another way to boost the power-handling capabilities of the circuit without upping the power rating of the Zener, is to use a Darlington power transistor. With a Darlington's typical gain figure of over 1000, the Zener would not be overworked. The maximum wattage of the "magnum" Zener would be wholly dependent upon the transistor's power-handling capacity. But be aware that the base-emitter voltage drop of the Darlington is about twice that of a standard power transistor.

Series Regulator

A typical series-regulated power-supply circuit is shown in Fig. 4. A series regulator controls the output voltage in

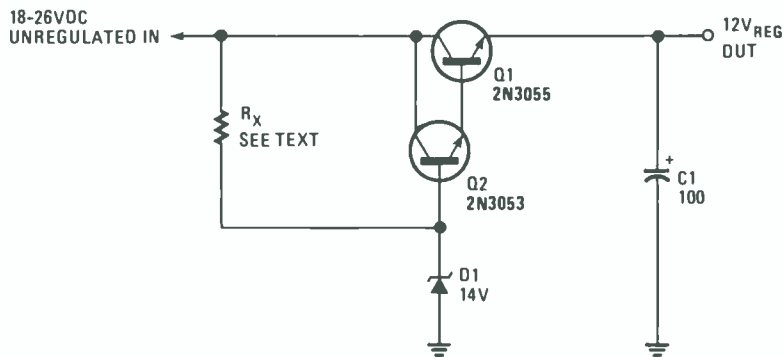

Fig. 5—A typical series-regulated power-supply (such as the one shown here) controls the output voltage in an opposite manner to that of a shunt regulator.

a manner that's the opposite of that used by the shunt regulators in Figs. 2 and 3. When idle, a shunt regulator dissipates the maximum power just to maintain a constant output voltage, making it less efficient for light to medium load applications. On the other hand, a series regulator draws very little while at standby, and burns up only the energy that's necessary to keep the output voltage constant while under load. That makes it the best choice of the two for the majority of our projects.

The regulator circuit in Fig. 4 is set up to provide a 12-volt 1-amp output, but the component values can be varied to suit almost any voltage/current combination. The transformer selected for T1 should be able to supply between 14 and 16 volts at 1.5 to 2 amps; the diodes, D1–D4, should be 1-amp, 100-volt silicon units, and C1 should have a minimum value of 5000 µF and be rated at 25 volts. Capacitor C2 should be no smaller than a 100-µF, 25-volt unit. Transistor Q1 should be able to handle a minimum of 15 watts, while maintaining a gain of 50 or better with a collector current of 1 amp. To build your own series-regulated power supply follow the method outlined.

If a 16-volt transformer is used, the DC output voltage across C1 will be

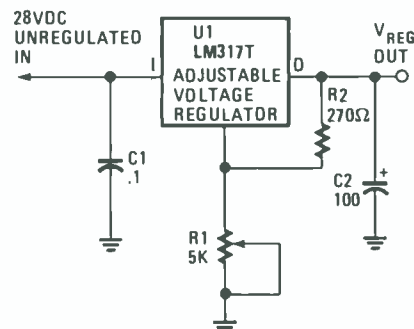

Fig. 6—By far, the easiest way to build a regulated power supply is to use a three-terminal regulator, like the LM317T. Shown here is a 2- to 25-volt, 1.5-amp adjustable power supply.

about 23 volts (or 16×1.41). Using a power transistor with a minimum H_{fe} of 50, the needed base current can be determined by I/H_{fe} , which works out to 20 mA for 1 amp of collector current. Add 10 mA as a safety margin, and use the total figure ($20 + 10 = 30$ mA) as the base current (I). The value of R_x is then $23 - 13 / .03$ or 333 ohms, where 23 is the rectified (no load) output voltage, 13 is the Zener's voltage rating, and .03 is the required base current. Either a 330- or 270-ohm 1-watt resistor is suitable for R_x .

Under light or no-load conditions, the power transistor requires very little base current. The maximum power that the Zener dissipates is calculated by multiplying 30 mA by 13 volts, which works out to 390 milliwatts ($P = E \times I$). A half-watt Zener might work, but a 1-watt unit would be a better choice.

In the shunt-regulator circuit, we gained the base-emitter voltage drop in the output, but in the series-regulator circuit that voltage is lost. So to make the output of the series-regulator close to 12 volts, a 13-volt Zener is used.

If a higher output current is needed, move on to the series regulator circuit shown in Fig. 5. Two power transistors
(Continued on page 99)

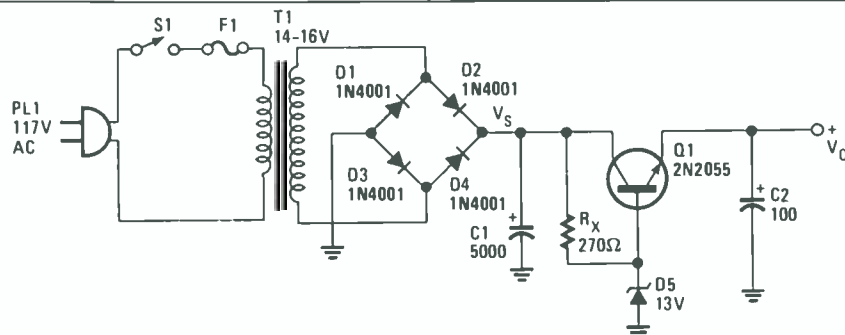

Fig. 4—The power-handling capabilities of the circuit in Fig. 3 can be further enhanced by replacing the bipolar transistor with a Darlington power transistor.



By Don Jensen

JENSEN ON DX'ING

A West African SW broadcaster that truly lives up to its name

□ "WE'RE NUMBER 1!" BASKETBALL enthusiasts chant it in unison. An NFL defensive back mouths the words to the close-up TV camera after a spectacular interception. For most who claim the top spot though, it's wishful thinking... a mere boast.

An exception is *Africa No. 1*, a shortwave station that in eight years has grown up to its name, with a daily listening audience of 15 million Africans! Each month, the station at Moanda-Moyabe, near Liberville (the capital of the West-African nation of Gabon), draws some 3,000 listener letters.

Africa No. 1, unlike most of the dull government-operated radio voices of the continent, has a lively, fast-moving sound and plenty of music aimed at a young, black, and largely French-speaking audience. It is a commercial venture, but it has relied on fat subsidies from the French and Gabonese governments during its early years.

In 1988, though—with its solid showing with African listeners—Africa No. 1 probably will turn a profit on expected revenues of \$10 million! "Radio is the inheritor of Africa's oral tradition," station director John Joseph Mbourou told the *New York Times*' James Brooke. "It is Africa's ideal means of communication."

Africa No. 1 has built a reputation for providing reliable news, something of a rarity in its part of the world. The station has a network of freelance correspondents in the 14 nations of West Africa, plus Paris and Washington. "We have the power to be much more free in the way we treat the news," Mbourou notes.

While Africa No. 1's play list includes West-African pop-music stars like Papa Wemba and Alpha Blondy,

*CREDITS: John Tuchscherer, WI; Karl Forth, IL; Sheryl Paszkiewicz, WI; Charles Rippel, VA; John Topoleski, PA; Richard Eckman, CA; Jim Uerlings, OR; Richard Lemke, GA; Harold Levison, PA; North American SW Association, 45 Wildflower Road, Levittown, PA 19057.

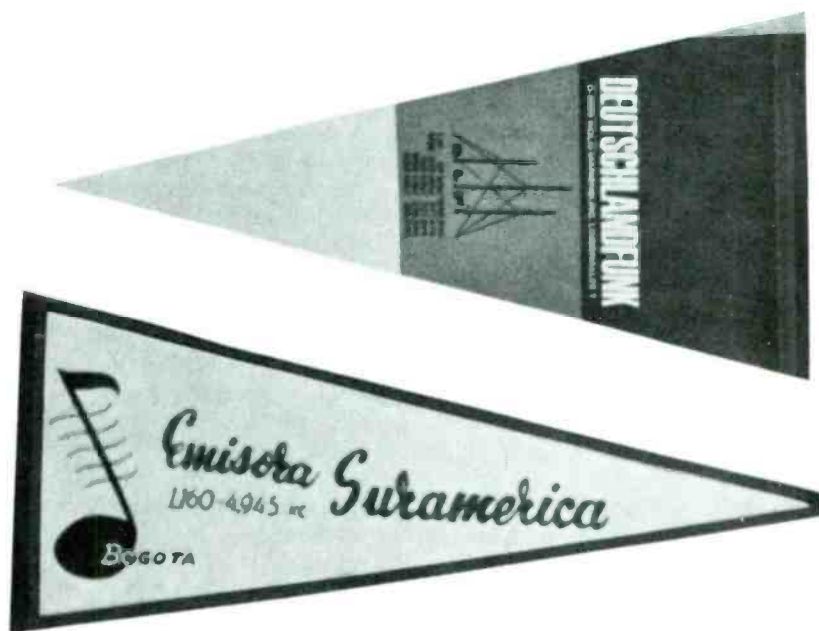

Shown here are two pennants typical of the kind sent, on occasion, by some shortwave stations to listeners who send in reception reports.

American-Black music is what pulls the young audience. Africa No. 1's own *International Hit Parade* recently listed songs by American-Black performers in eight of the top-ten spots and 15 of the highest-rated 25 records. A station DJ noted that Black-American music is what young people want to hear. "Some French guy singing *Je t'aime, je t'aime* doesn't do much for me," he said.

Besides today's music, American and African, the shortwave broadcaster's 18-hour broadcasting day includes programming staples like interview shows, quiz programs, and soap-opera dramas. But one of its top-rated programs is the afternoon program, *Triangle*, focusing on dream meanings and the occult.

Africa No. 1 uses four powerful 500-kilowatt shortwave transmitters and a fifth is being installed. With all that wattage on hand, more than it can use

for its own programming, the station sells air time to several international broadcasters, including *Radio France International* (RFI), *Radio Japan* and *Swiss Radio International* (SRI), to relay their shortwave broadcasts.

The French government has been behind the scenes with money and technical expertise from the very start, establishing a Gallic presence and a solid relay base for RFI programming in that francophone corner of the world.

Shortwave listeners in the U.S. and Canada may find Africa No. 1 on these frequencies, depending on the time of day: 4830, 7200, 11,940, 15,200, 15,475, or 17,870 kHz. During the North-American afternoon hours, try 15,475 kHz, for instance. In French, the station identifies itself as *Afrique Numero Un*. You can address your reception reports to Africa No. 1 at—no surprise—Box 1, Libreville, Gabon.

Pennant Fever

Just a quick and to-the-point note from Bob Johnston of Pittsburgh, PA. "I've heard that stations send out pennants, as well as QSL cards, to listeners who write to them. What can you tell me about that practice?"

That's true Bob, although not all stations, by any means, do it. Cloth—sometimes vinyl—pennants with the station name, slogan, frequency, and the like are sometimes sent to listeners as "thank you" mementos for useful letters and reception reports.

The Latin-American shortwave stations are particularly likely to enclose pennants with their replies, but I've got a wall full of those colorful triangular station "flags," including *Radio Beijing*, *Radio Nederland*, *Radio Canada International* (RCI), and *RTB Belgium* among the non-Latin stations.

Those souvenirs were collected over the years and some of the stations may not currently be offering pennants, but it never hurts to politely ask when you mail off your reception reports to SW broadcasters.

Feedback

We always welcome your letters, comments, and questions on shortwave subjects, including (by the way) your SW loggings for our monthly "Down the Dial" segment. The address is *Jensen on DXing, Hands-on Electronics*, 500-B Bi-County Blvd., Farmingdale, NY 11735.

How does a lonely GI pass the time when he's perched on a mountain top half the world away from home?

Pfc James Dinsmore, with the Army's 74th Signal Co. at a remote microwave-repeater station near Pusan, South Korea, has the answer. He says, "There's not a lot of entertainment up here, so my shortwave receiver has become one of my most-valued possessions, providing many hours of fascination. It's not a high-class set—in fact, I think the SW bands were an afterthought, added to an AIWA tape player—but here on the rim of the Pacific, I've been able to log 19 countries, from West Germany to Australia."

James suggests that readers who are in military service and going overseas, or civilians traveling abroad, for that matter, bring along their shortwave portables. Since his receiver doubles as a tape recorder, James records samples of each station he hears, sending cassettes home to his wife in the States, so that

she can share in his listening interests.

Another advantage of taping your shortwave catches, James notes, is being able to play back the receptions. "Distant, noisy stations may have a nearly unintelligible station identification, so I can play it back repeatedly until I can decipher it." Probably James' best catch, he notes, is *Radio Ulan Bator* in Mongolia, which he admits "sent me to my world atlas to locate it. SW has taught me a lot of geography!"

James has a tip for other listeners: Make a chart plotting the time of receptions on one axis against frequencies on the other. "As I drew mine up, it became apparent that my listening habits left holes or voids in both times and frequencies. There were time periods when I hadn't logged any new stations. The same was true for certain frequency ranges.

ABBREVIATIONS

NFL	National Football League
kHz	kilohertz (1000 hertz or cycles)
Pfc	Private First Class
QSL	verification reply from broadcaster
RCI	Radio Canada International
RFI	Radio France International
SRI	Swiss Radio International
SW	shortwave
TV	television
US	United States
UTC/GMT	Universal Time Code/ Greenwich Mean Time

"By concentrating on those 'holes' for just one day, looking for stations at times and on frequencies where I hadn't previously listened, I came across three new ones!" Pfc Dinsmore also sent along a most interesting cassette tape that contained some of his many shortwave loggings.

Down the Dial

Here is what some listeners in the U.S. and Canada have been hearing. All times are listed in Universal Coordinated Time (UTC); and frequencies are given in kilohertz (kHz).

Chile—15,140; *Radio Nacional de Chile* has been heard here from around 2230 UTC with a Spanish-language news broadcast.

Gabon—7200; Our featured station this month, *Africa No. 1*, has been logged from 0530 UTC with French news, identification in both French and English, and African music.

Greenland—3999; *Gronlands Radio* is definitely not an easy logging, but

the best time to hear it seems to be at the start of its morning programming, just before 1000 UTC.

Lesotho—3255; The *British Broadcasting Corporation's* shortwave relay in southern Africa has been noted here with English-language news at 0400 UTC.

Mali—9770; The programming here may be *Radio Beijing's*, but the transmission is not coming directly from China. If you hear this one around 0200 or 0300 UTC, the signal is being relayed by a West African transmitter in Mali.

Nepal—5005; A number of listeners report hearing *Radio Nepal* with programming in the Nepali language, during the 1200 to 1330 time period. Because Nepalese time is out-of-synch with the rest of the world, listen at 1215 UTC for the "pip" tone that marks their local hour.

Netherlands—6020; The Happy Station program has been around for 60 years, longer than any other show on SW. It is broadcast by *Radio Nederland* each Sunday night, our time, which is 0230 UTC Mondays.

U.S.—6150; Although it often suffers from Soviet interference, you may find the religious broadcaster, *KNLS*, from Anchor Point, Alaska, signing on with English-language programming at 0800 UTC.

Another US SW broadcaster, New Orleans' *WRNO Worldwide* (21,825), has been noted on that high-band frequency with an English-language religious program at 1730 UTC. A growing number of stations can be found these days on the 21-megahertz band. ■



"Gee guys, thanks for the opportunity to work some real DX. Just think—Alpha Centauri!"



SAXON ON SCANNERS

If you're in the market for a scanner base station, check this one out

□THE R-2060 FROM REGENCY IS THIS company's recently released high-technology scanner. Loaded with today's communications goodies, such as *Turbo Scan* capabilities, it's what scanner users call a "base station unit" (the manufacturer refers to it as a "home scanner"). The Turbo Scan feature permits the unit to scan at a whirlwind rate of 50-channels per second.

The unit covers the VHF-low band (30 to 50 MHz), 2-meter ham band (144 to 148 MHz), VHF-high band (148 to 174 MHz), UHF-federal band (406 to 440 MHz), UHF-ham band (440 to 450 MHz), UHF public-safety and industrial bands (450 to 522 MHz).

A special front-panel key gives you instant weather information on your locally active NOAA 162-MHz channel. There are 60 programming channels, segmented into four banks of 15 each. Other features include priority, lockout, delay, hold, and search/scan. The volume and squelch are operated with slide controls. A dual-intensity, vacuum-tube, fluorescent display provides all necessary information.

The Regency R-2060 comes with a telescoping antenna and provisions for an external antenna. It operates from 117 volts AC. It carries a suggested retail price of \$249.95, and it comes from Regency Electronics, 7707 Records Street, Indianapolis, IN 46226.

The division of Regency Electronics that produces scanners, by the way, was recently purchased by the Uniden Corporation of America (producers of Bearcat scanners). At the time of this writing, no announcement had been made regarding whether Uniden will retain the Regency name for those products, or if they will all be dubbed as Bearcats, or Regency-Bearcats, or what?

Here's a Plug

A letter from Howard Martinson of Delaware reports that his new scanner has a BNC-type, female antenna con-

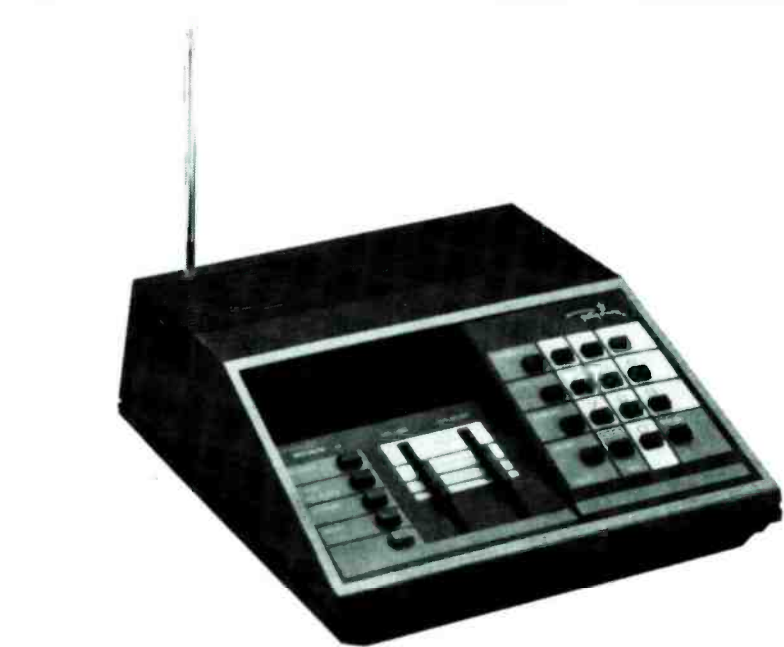

Regency's R-2060 scanner is loaded with today's communications goodies, such as *Turbo Scan* (which permits the unit to scan at a rate of 50-channels per second), and covers the VHF-low band, 2-meter ham band, VHF-high band, UHF federal band, UHF ham band, UHF public-safety and industrial bands. It has 60 programming channels (segmented into four banks of 15 each), priority, lockout, delay, hold, and search/scan; comes with a telescoping antenna (with provisions for an external antenna), and operates from 117 volts AC.

nect, but the coaxial-cable assembly that he purchased with his antenna, was made up with PL-259 plugs. That creates a definite interfacing problem.

The fact is that Howard's little dilemma is not all that uncommon; we have received similar letters from people who note that the prewired coaxial assemblies containing PL-259 plugs don't match up with the various types of antenna connectors usually found on scanners. Unless you wish to install a dedicated lead-in made up with a special plug for a particular scanner, the way out is by using various convenient adapters to get everything to match up properly.

A wide selection is available to meet most needs. For instance, Howard's problem of getting a PL-259 on the coaxial cable to match up with a female

BNC on the scanner is instantly solved with a type UG-255/U adapter. Similar adapters are available for scanners having a car-radio or phono-plug antenna inputs. With the proper adapter you can match anything to anything. About the prices...they're low-cost (less than \$3 each). Figure out what has to match with what, and then ask at your local communications shop (or check out the assortment listed on page 135 of the 1988 Radio Shack catalog).

With adapters, you don't have to install special connectors on antenna leads that restrict their use to only one scanner. Maybe someday the scanner industry will standardize one type of connector and the problem will no longer exist. Our vote is for universal use of the BNC-type for all scanners.

(Continued on page 94)



By Herb Friedman

FRIEDMAN ON COMPUTERS

Polling devices allow single serial DCE devices to be used by many computers

□ MANY YEARS AGO, SOMEONE wrote—with no jest intended—that Polaroid cameras should be given away free, because once you owned one, you were faced with a lifetime of never-ending film and accessory costs.

In a way, the same thing can be said of personal computers. No one is really happy with just a computer; there's always a new gadget "that will give you an extra dimension in computing power." Put one computer in an office and you'll soon have many. Give one computer a modem to send messages to a field office, or to access an on-line information service, and suddenly everyone needs a modem "or they just can't get their work done." Connect a laser printer to one computer for classy reports and suddenly everyone needs their own laser printer "to keep up with the competition," or "to turn out quality term papers," or any of a hundred other reasons.

The problem is, however, that even if all the reasons for ancillary computer hardware were justified, much of the time a lot of high-priced gear would be sitting idle. And if anyone suggests moving the equipment to where it's needed, when it's needed, people who can interconnect a TV/VCR/Hi-Fi/microwave home-entertainment and cooking center having more cables than an octopus has tentacles, become helpless bumpkins incapable of moving a single printer cable from computer A to computer B.

One For All

It is precisely to get around the problem of buying many little-used devices that we're starting to see greater use of automatic resource-sharing devices—which, for the sake of brevity, we will henceforth refer to as RSDs.

Essentially, an RSD allows a single serial device with an RS-232C I/O to automatically connect to one of many personal computers when it is needed. For example, consider an office or a

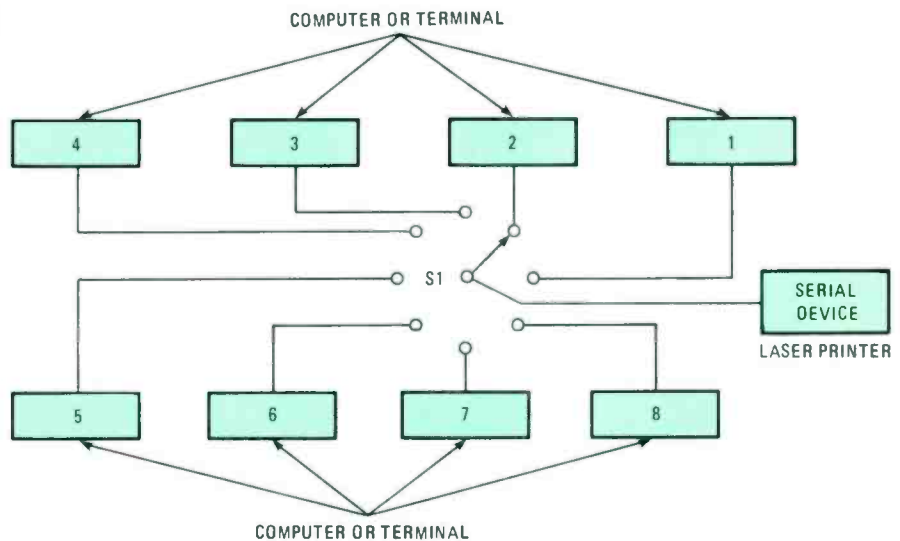

Fig. 1—In this functional schematic of an RSD, switch S1 represents an electronic switch that continuously polls up to eight serial computers or terminals. When the RSD receives an RTS signal from a computer or terminal, S1 locks onto the computer, and connects its I/O to the printer.

school classroom with several personal computers and a single laser printer. As soon as computer A is ready to print, an RSD determines that computer A is *asserted*—meaning it's ready to print—and automatically connects the printer to computer A's serial port.

If any other computer—perhaps computer C—asserts itself while the printer is occupied with computer A, the RSD automatically holds off computer C's output until computer A is finished printing. At that time, the RSD automatically connects to computer C and "instructs" computer C, via an electrical handshake, to commence printing.

Polling

The RSD determines which computer to connect through a process known as *polling*. For example, as shown in Fig. 1, the *Telebyte Model 327 Modem Allocator* has RS-232C I/Os for eight computers or terminals and a serial device, such as a modem or a printer. In

our example, the serial device is a laser printer. An electronic switch in the RSD, which is labeled S1 in Fig. 1, continuously scans the eight computer/terminal I/Os looking for an RTS; RTS is an electrical handshake signal that means *Ready To Send*. When the RSD detects an RTS, it stops its polling, switch S1 "locks" onto the computer, and the RSD asserts its CTS handshake. The CTS signal, which means *Clear To Send*, tells the computer that it is connected to the printer via the RSD, and the computer can start outputting its data to the printer.

When the computer is finished outputting to the printer it drops its RTS signal, thereby releasing the RSD, which resumes its polling until it finds another RTS signal.

An RSD device works the same way for a modem; in fact, it works the same way for any serial device that uses RTS/CTS handshaking. (RTS/CTS handshaking is called *RTS/CTS protocol* by
(Continued on page 94)



By Joseph J. Carr, K4IPV

CARR ON HAM RADIO

Multi-band wire antennas

□ LAST MONTH IN THIS COLUMN, WE discussed the old-fashioned dipole antenna. Although disdained by the "big antlers" crowd, the simple half-wavelength dipole turns in a laudable performance; especially when price is a consideration. This month we are going to expand the focus a little bit and deal with multi-band, wire antennas, which are low-cost alternatives to the beam.

Although a tri-band beam antenna will undoubtedly work better than a wire antenna (when installed correctly!), the low-budget amateur operator need not lament any supposed inability to "get out" on wire antennas. To quote an old saying: "Better is the enemy of good enough." If it's "good enough" don't waste a lot of energy fretting over making it "better," unless you *really* want to make it better.

Trap Dipoles

Perhaps the most common form of multi-band wire antenna is the trap dipole, shown in Fig. 1. In that type of antenna, one or more pairs of parallel-resonant traps are placed in series with the quarter-wavelength elements of the dipole. The purpose of the traps is to block their own resonant frequency, while passing all other frequencies. In Fig. 1, a 10 meter trap isolates the first eight feet or so (a quarter wavelength at 10-meters), so that the antenna resonates on that band.

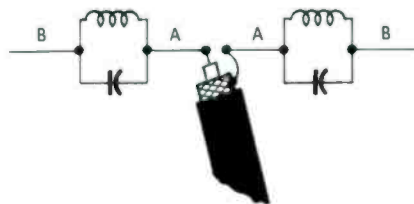

A = 10-METER SEGMENT
A + B = 15-METER/40-METER SEGMENT

Fig. 1—Trap dipoles are perhaps the most common form of multi-band, wire antenna. The antenna uses one or more pairs of parallel-resonant traps that are placed in series with the quarter-wavelength elements of the dipole.

A 40-meter or 15-meter signal, on the other hand, passes through the traps and uses the whole length of the antenna (note: a half-wavelength 40-meter dipole works as a $\frac{3}{4}$ -wavelength antenna on 15-meters). The overall length of the trap dipole will be a little less than the natural *non-trap* length for the lowest frequency of operation. At the lower frequencies, the traps add a little inductance to the circuit so that the resonant point is lower than the natural resonant frequency.

In general, most trap dipoles are just a few percent shorter than non-trap dipoles for the same band. The actual amount of shortening depends on the values of the components in the traps, so consult the data for each trap purchased. Where more than one pair of traps are used in the antenna, make sure that they are of the same brand and are intended to work together.

Tuned-Feeder Antennas

Figure 2A shows the tuned-feeder type of antenna. The antenna can be used from 80 through 10 meters, but requires a special tuner and a length of parallel transmission line. There are two ways to get parallel transmission line: make it or buy it. Using #14 or

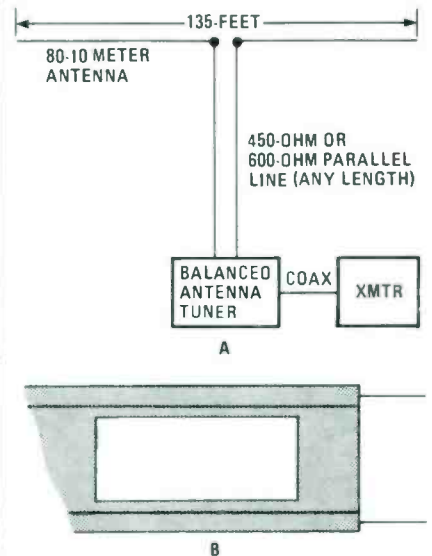

Fig. 2—Tuned-feeder antennas (an example of which is shown in "A") can be used on from 80 to 10 meters, but require a special tuner and a length of parallel transmission line. You can buy insulated 450-ohm twin-lead ("B") that can be handled as easily as TV twin-lead.

#12 wire, and specially made insulators (also called "spreaders"), you can make 300-ohm, 450-ohm, or 600-ohm parallel transmission line.

But that's a pain in the neck, especially since you can also buy parallel line rather cheaply. I paid \$16 for 100 feet of 450-ohm line recently. One form of parallel line is ordinary TV-type twin-lead, which has an impedance of 300 ohms. That line will take up to about 250 watts, although some people use it at higher powers (not recommended).

The antenna in Fig. 2A uses 450-ohm parallel line. You can buy insulated 450-ohm twin-lead (see Fig. 2B) that can be handled as easily as TV twin-lead, and a lot easier than open (uninsulated) parallel line. Radiokit, one of the dealers listed in Table 1, stocks 450-ohm, parallel-line twin-lead.

(Continued on page 100)

TABLE 1 ANTENNA MATERIAL SOURCES

- Radiokit PO Box 973, Pelham, NH, 03076; Tel. (603) 635/2235
- Barker & Williamson, 10 Canal Street, Bristol, PA 19007; Tel. (215) 788/5581
- Unadilla/Antennas Etc., PO Box 215 BV, Andover MA 01810-0814; Tel. (617) 475-7831
- Van Gorden Engineering PO Box 21305, South Euclid, OH 44121
- SPI-RO Manufacturing, Inc. PO Box 1538, Hendersonville, NC 28793
- Alpha Delta Communications, Inc. PO Box 571, Centerville, OH 45459; Tel. (513) 435/4772



NOW
Hands-on
Electronics[®]
Every Month!

■ IF YOU'RE THE KIND OF READER that doesn't want to wait, you can order your next copy of **Hands-on Electronics** now. **Hands-on Electronics** is crammed full of electronic projects that you won't be able to wait to build for yourself. You can expect top-notch digital projects, fun-to-play electronic games, valuable add-on computer projects, BCB and shortwave receivers, photographic/darkroom gadgets, devices to improve your car's performance, test equipment ideas, and more in every issue of **Hands-on Electronics**.

■ YOU CAN HAVE THE NEXT TWELVE ISSUES of **Hands-on Electronics** delivered to your home for only \$18.95 — saving \$11.05 off the single copy price.

■ EVERY ISSUE OF **Hands-on Electronics** will continue to contain a variety of construction articles to suit every taste. In addition, feature articles on electronics fundamentals, test equipment and tools will round out each issue. Of course, **Hands-on Electronics** will continue to provide new product and literature listings to keep you up to date on the latest developments in electronic technology.

■ GET IN ON THE ACTION! Order your next issue of **Hands-on Electronics** today. Use the convenient order coupon below. Be sure to send check or money order—no cash!

Hands-on Electronics SUBSCRIPTION ORDER FORM

I want to be sure I don't miss any issues. Send me ONE FULL YEAR — twelve issues — of **Hands-on Electronics** for \$18.95 (Canada \$23.95 U.S. Funds).

Payment Enclosed

Please charge my

Visa

Mastercard

Signature _____

Bill Me Later

Acct. # _____

Exp. Date _____

Allow 6-8 weeks for the first issue to arrive. Offer valid in U.S. Funds Only.

Please print

 (Name)

 (Street Address)

 (City)

 (State)

 (Zip)

Detach and mail today to:

HANDS-ON
 ELECTRONICS
 SUBSCRIPTION DEPT.
 P.O. BOX 338
 MOUNT MORRIS, IL
 61054

AHOJ8

SEPTEMBER 1988

SAXON ON SCANNERS

(Continued from page 88)

Flight Check

The radio-navigation facilities at various airports are subject to being regularly checked by the FAA to assure that they are operating properly. A malfunctioning or inoperative radio-navigation aid could have disastrous consequences.

The FAA, therefore, has a fleet of equipment-loaded aircraft that do nothing but shoot test landings at airports while they measure the accuracy and operations of the instrument landing systems. While they perform those duties, they are invariably in two-way radio contact with communications technicians on the ground that perform any necessary tuning adjustments on the equipment in order to bring it to within FAA specs.

Those so-called *Flight Check* operations take place in the VHF-aeronautical band on 135.85 and/or 135/95 MHz. For anyone interested in communications, avionics, or aeronautics, such activities can be quite fascinating.

Inasmuch as the fleet of test aircraft

constantly moves from place to place, you won't hear those activities until the ILS systems in your general area are being checked. If you've got two open channels in your scanner, punch in those two frequencies and sit tight until they periodically activate.

Real Pro

We continue to receive requests for information on step-by-step procedures for restoring the Cellular Mobile Telephone (CMT) 800 MHz frequencies in Radio Shack's PRO-2004 scanner. You'll recall that Radio Shack had at first announced that the PRO-2004 would receive those frequencies; but before the unit came on the market it had been factory-modified to have the CMT frequencies blanked out. Several issues ago we presented the basics of restoring the CMT bands in the PRO-2004. While many readers found that the information we presented was sufficient, a number of readers asked for more information, or commented that their PRO-2004 was set up slightly different than we had described.

For those who feel they need additional conversion information, send me

a self-addressed, stamped (25 cents U.S.) long envelope, and I'll pass along a set of step-by-step instructions for putting the 800-MHz band CMT frequencies back in the PRO-2004. That information should take care of all problems, including those relating to the few PRO-2004's that have slightly different wiring configurations. Be sure to mention in your letter to me that you want the PRO-2004 information so that your request will be answered promptly and properly.

A Very Moving Request

Billy Wendell, Atlanta, GA wants to know the transit-police frequency for the Metropolitan Atlanta Rapid-Transit Authority. That would be 452.475 MHz. Listen for other (non-police) MARTA operations on 452.375, 452.775, and 452.875 MHz.

We'll be with you again next issue. Pass along any questions, comments, station photos, loggings, and requests (accompanied by a long SASE) for the PRO-2004 data to "Marc Saxon," *Saxon on Scanners*, *Hands-on Electronics*, 500-B Bi-County Boulevard, Farmingdale, NY 11735. ■

FRIEDMAN ON COMPUTERS

(Continued from page 91)

RSD manufacturers.) For example, assume the XYZ company has spent big bucks for a Class-5 2400-baud modem (see our column on Class-5 modems in the August 1988 issue of *Hands-on Electronics*). The company's owner is not going to be ecstatic at the thought of buying everyone their own Class-5 2400-baud modem, since they can cost more than some computers. Instead, he buys one modem and an RSD, which interconnects up to eight computers to the single Class-5 modem.

The RSD continuously polls the computers looking for an RTS signal. As soon as the RSD senses that a computer's serial port has asserted its RTS handshake, it electrically connects the modem to that computer and asserts its own CTS handshake. The computer knows the CTS signal means that it's connected to the modem, so it does its thing. When finished, the computer drops its RTS, thereby releasing the RSD, can resume polling the other computers, looking for an RTS handshake.

Regardless of what the controlled device is—modem, printer, plotter, LCD

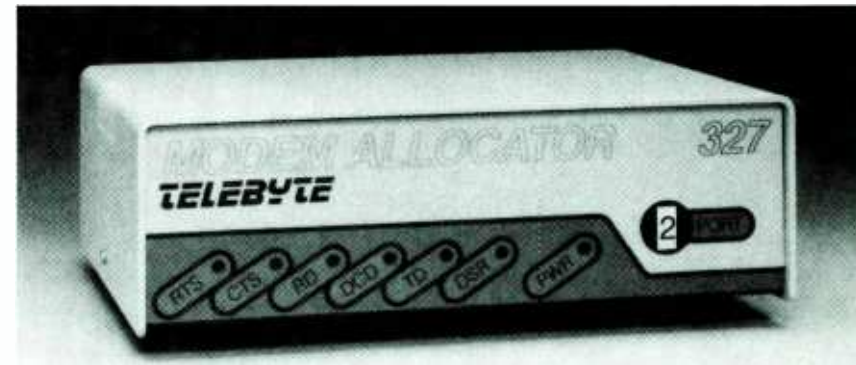

This RSD has signal lights that are used by the unit to indicate the port number, the state or condition of all common RS-232C electrical handshakes, and the presence of receive (RD) and transmit (TD) data.

projector display, or whatever—the RSD won't stop polling and lock onto a computer until it senses an RTS handshake from a computer, and no computer starts sending data until it receives the CTS handshake from the RSD.

It's Familiar

If you have done any work with modems, printers, or even printer buffers, you're probably familiar with the CTS/RTS protocol. You'd know that none of the devices work automatically without the CTS/RTS handshaking, because that's what keeps the computer from either feeding into a "dead" circuit, or

overrunning the serial device with data if the device can't process the data as fast the computer spits it out. Essentially, all the RSD really does is add a multi-port polling circuit to a CTS/RTS controller.

Of course, things can go wrong. To prevent an RSD from being locked by a CTS/RTS handshake when something else has failed, the typical RSD uses the same accessory signal control as a conventional automodem. For example, as shown in the photo, the front panel of the Telebyte Model 327 has a port indicator that lets you know what comput-

(Continued on page 96)

This will be coming to you when you subscribe to **Radio-Electronics**

- **HELPFUL CONSTRUCTION ARTICLES...**
 - Test Equipment
 - Hi-Fi Accessories
 - Telephone Accessories
 - Music Synthesizers
 - Computer Equipment
 - Automotive Equipment
 - Intruder Alarms-Home & Car
 - Video Accessories
- **NEWS ON NEW TECHNOLOGY**
 - Computers
 - Microprocessors
 - Satellite TV
 - Teletext
 - Automotive Electronics
 - Speech Synthesizers
 - IC Applications
- **FASCINATING "HOW TO DO IT" ARTICLES...**
 - Build Your Own Projects
 - Make Your Own PC Boards
 - Wiring Techniques
 - Soldering and Desoldering
 - Design and Prototyping

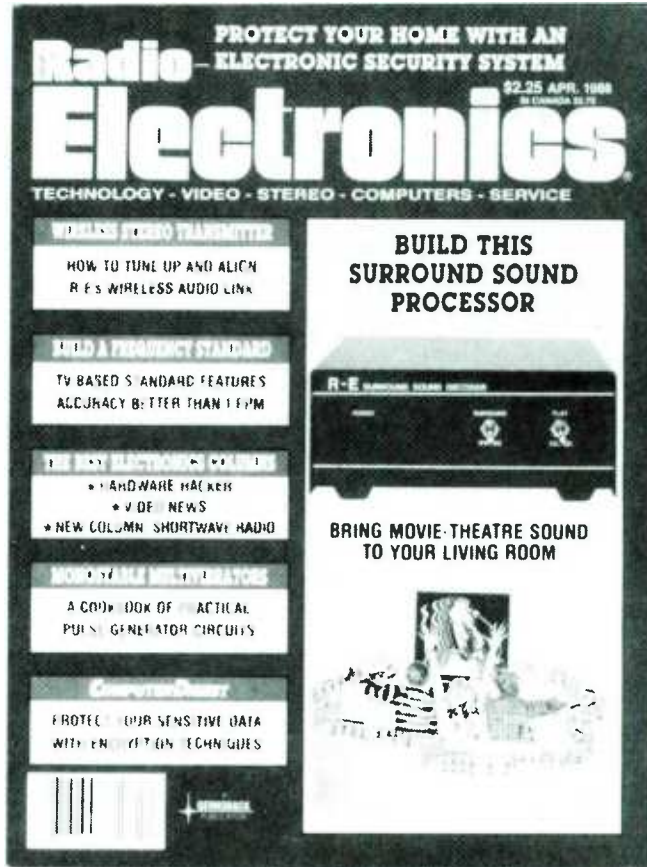

- **HOW YOU AND THE COMPUTER CAN BE FRIENDS...**
 - Getting Started
 - Programs, Circuit Design, Games
 - A/D-D/A Interfacing
 - Peripheral Equipment
- **NEW AUDIO DIMENSIONS FOR YOUR PLEASURE...**
 - Noise-Reduction Devices
 - How to Connect that Extra Add-On
 - Hi-Fi Accessories
 - New Technology
- **TV WONDERS FOR YOUR FUTURE...**
 - Latest Receivers and Circuits
 - The Home Entertainment Center
 - Projection TV
 - Satellite TV Receivers
 - Jack Darr's Monthly Service Clinic
 - Service Problems and Solutions
- **REGULAR MONTHLY FEATURES**
 - DESIGNERS NOTEBOOK by Robert Grossblatt
 - HOBBY CORNER by "Doc" Savage, K4SDS
 - STATE-OF-SOLID-STATE by Bob Scott
 - WHAT'S NEWS, new products, stereo news and NEW IDEAS, STEREO PRODUCTS, NEW COMPUTER PRODUCTS FOR HOME/JOB and MUCH MORE!

Radio-Electronics covers all aspects of the fast moving electronics field...featuring **COMPUTERS • VIDEO • STEREO TECHNOLOGY • SERVICE COMMUNICATIONS • PROJECTS**

Get it all!

Subscribe today to **Radio-Electronics**! Don't miss a single issue and...see subscription card in this issue for big savings.

When you select one of the subscription offers listed on the handy coupon—you'll be assured of having your copy reserved, even if it sells out on the newsstand. Make sure you get all the excitement in every issue of **Radio-Electronics**, every month, by filling in and mailing your subscription card today.

FRIEDMAN ON COMPUTERS

(Continued from page 94)

er is being polled or is connected, and a series of indicator lights that tell you the condition of the RTS, CTS, DSR (Data Set Ready), and DCD (Data Carrier Detect) handshakes, and whether there is a received signal (RD) into the RSD and

computer, or a transmitted signal (TD) out of the computer and into the RSD.

Of course, an RSD is not the be-all or end-all for all computer I/O problems. If a computer needs a modem available for instant use, or a printer is so busy handling the output of just one computer that it simply can't be spared, then the computer should have its own dedi-

cated modem, printer, or whatever it needs. The RSD device shows its value primarily when a particular peripheral will be infrequently used by any of many computers.

For more information on the Telebyte Model 327, write to Telebyte Technology, Inc., 270 E. Pulaski Rd., Greenlawn, NY 11740. ■

OLD-DOG—NEW TRICKS

(Continued from page 50)

"No, but that's the base requirement. The difference between this and a typewriter, or your old trencher, is that each time you want to do something different you have to give it a different set of instructions called a program."

Reeling in

I stopped for a moment to watch for impact. His head was thrust toward the screen like a pointer on quail. I hardly dared breathe for fear of breaking the spell. I went on softly, "The display on the screen tells us that we can now do word processing. That's a fancy word for writing something down. If we wanted to draw or calculate we'd open up another program like going into another room of a large house. But you're used to that. Every time you put your trencher on a new job you had to reset it, right?"

He turned to me "Well, it wasn't *that* simple, but that's what happened."

I didn't give him time to reconsider. "Like your trencher, computers don't know anything until people tell them. Then you have to spell it out exactly and that's what the program will do. Once the program is in the computer then you can give it information and make it do work."

He wasn't totally convinced. "Computers are supposed to be complicated."

"They are, if you want to work on them. But remember, Papa, most trencher operators are not capable of tearing the machine down and they aren't expected to do it. But since you've known the basics of operating one of them for years, all you have to do on the latest model is add the up-dated

requirements and you can make it do work."

He drew a deep breath and turned back to the screen. Suddenly the dreaded monster had fallen into his frame of reference and he was ready to do battle. There was a new set to his shoulders and his eyes gleamed with anticipation.

"I can hunt-and-peck."

Cranking it Out

We spent the next five days mainly at the keyboard. He dove into the computer with the enthusiasm of a colt and devoured every bit of information I could give him. I kept him on floppies so he couldn't accidentally smear my hard drive, and he could be heard pecking away for hours at a time with his face barely eight inches from the screen.

I'd like to tell you that he's a whiz kid on the network circuit, but he's not. After a long week, he decided that my equipment had far more horsepower than he'd ever use and so we compromised. As a birthday present I promised him yearly labels for his newsletter out of my equipment and I gave him a used Sharp Intellwriter to take home with him.

Today I get letters. Used to be he'd write me once a month from California. Now I get one a week and I'm having trouble keeping up with the correspondence. I also get a copy of his newsletter. It is a single page, double spaced, copy-machine copy of his original with special words emphasized in large and bold. It is now his total creation without a typist in between. When I get it I can close my eyes and see him bent toward the screen, white beetle brows creased behind coke-bottle glasses, while two care-worn, arthritic index fingers peck out letter after letter.

After all, he learned the alphabet at four and that's all it takes to learn how to operate a computer. ■

ADD RAPIDFIRE TO YOUR JOYSTICK

(Continued from page 36)

board. Make the indicated connections between the circuit board and enclosure-mounted components. A hole can then be drilled in the joystick's plastic case, and the potentiometer and board mounted at the same time. Or the circuit can be housed in its own enclosure.

The shaft of R3 is fed through a hole in the board and the enclosure, and the potentiometer's mounting hardware used to secure the assembly in place. The unit is now ready to test.

Testing, One...Two...Three

Check the continuity from pins 1, 2, 3, 4, and 8 from one connector to the same pins on the other. Switch the AUTO/NORMAL selector to norm, and test for continuity on pin 6. If all is well, you have all four directions working, and the fire button works normally.

At this point, you may need another set of hands. On the female connector put +5 volts across pins 7 (+V.) and 8 (ground.). Plug your joystick into the box and push the fire

button. Check the voltage between pins 6 and 7 on the female side. If it is fluctuating between some high impedance and ground, you have a working RapidFire unit.

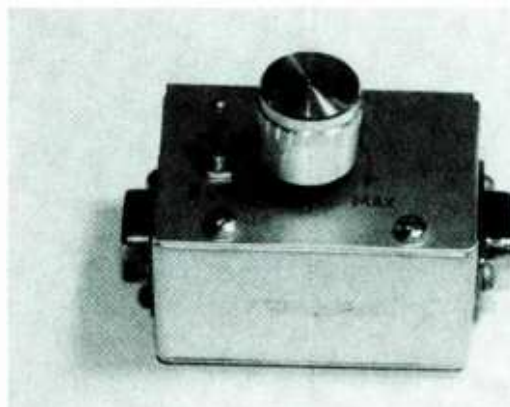

Shown here is the RapidFire unit housed within its own enclosure. The circuit can be housed separately (as shown here), or installed in the joystick's case.

AUDIO CRYSTAL FILTER

(Continued from page 32)

There are a couple of things that should be mentioned. The first is that there's a second peak at about 3000 Hz and all of the transducers I tried displayed a twin-peak characteristic. Fortunately both peaks are sharp, so the chances of having an interfering signal exactly on the second peak are slim.

Second, the Audio Crystal Filter doesn't remove the audio image as an IF filter would, but again, the peak is so sharp that interference is unlikely—and you can always retune to the other side of zero beat.

Finally, the frequency is a little higher than ideal for code work, but it's not uncomfortably shrill.

As far as I know this is the first use of a piezo resonator as an audio filter. Maybe a manufacturer will see the possibilities and make a transducer with a frequency of about 1000 Hz.

Construction

Building the filter is simplicity itself. I mounted the transducer on a small board to keep it from flopping around on the desk and used shielded wire and a quarter-inch phone plug to attach it to the phone jack of whatever receiver I'm using it with. Neither the board nor the shielded wire is necessary, so suit yourself as to how you build it. You might even glue the transducer into one side of a pair of earphones and switch it in when maximum selectivity is needed.

Some transistor sets may require a DC path through the speaker. In that case use an 8-ohm to 1000-ohm transformer, connecting the 8-ohm side to the radio and the 1000-ohm winding to the transducer.

In using the filter, avoid turning up the volume too high.

PARTS LIST FOR THE AUDIO CRYSTAL FILTER

BZ1—Piezo electric crystal
 PL1—Mono phone plug
 T1—8-ohm to 1000-ohm matching transformer
 (optional; see text)
 Shielded cable, solder, a small board, Fahnestock clips,
 etc.

Dead Men Don't Use RapidFire

Once you plug the unit in and switch to RapidFire, you might notice a slight delay between the time you push the fire button and when something actually happens. That occurs because the 555 starts its oscillation with a high output. The low half of the output is the one that simulates the push of the fire button. That is a small sacrifice to bear and will usually go unnoticed. If you do need timing over firepower, just flip S1 (the selector switch) to normal!

You may also notice that the optimum firing speed isn't always top speed. Since most games don't expect you to push the fire button at fifteen Hertz, the fire rate may actually be lower at higher oscillator speeds. Because of limitations on the number of shots allowed on the screen, a burst effect may occur at high oscillator speeds. Hold down the fire button and adjust until the optimum rate is achieved.

Since you no longer have to constantly pound that silly button to destroy endless swarms of Technicolor *Rabbits*, you'll notice your scores rising and your joystick lasting longer; and the bruises on the ends of your fingers should be disappearing soon. ■

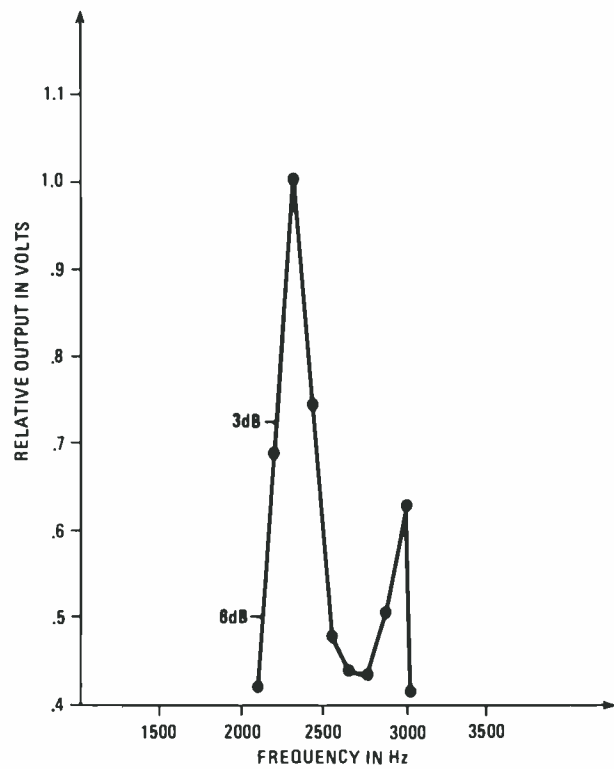

Fig. 1—The selectivity curve of a typical transducer. Not bad for less than two dollars and five minutes work! The audio crystal filter will greatly improve the selectivity of many receivers or transceivers if properly used.

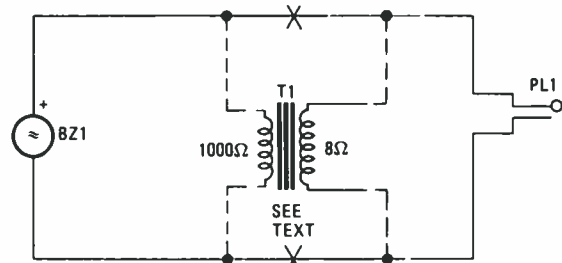

Fig. 2—Some transistorized setups will require a path to ground. You can accommodate those rigs by using an impedance-matching transformer. Be sure to connect the buzzer to the 1000-ohm side, and the 8-ohm side to the phone plug.

The filter removes noise as well as unwanted signals, so the receiver will sound much quieter than with an ordinary speaker. That is normal. If the volume is turned too high, signals away from the peak will come through causing your ear-brain signal processor to start averaging them and you won't realize the full potential of the filter. Also, turning the volume up may start the crystal vibrating in other modes, further complicating the problem.

The Audio Crystal Filter is something new in the long battle against interference. Its performance will greatly exceed its modest cost and simplicity. ■

Help Prevent Birth Defects—
 The Nation's Number One
 Child Health Problem.



Support the
March of Dimes
 BIRTH DEFECTS FOUNDATION

This space contributed by the publisher

SQUIRT-GUN TAG

(Continued from page 31)

vest should match the user. A typical pattern for a child 3½–5 feet tall is shown in Fig. 6. For a larger person, increase dimensions accordingly. The author attached the PC-board targets to the vest with Velcro tape.

One piece of Velcro was attached to the back of the PC-board target and the other to the vest. The target then “sticks” to the vest. Velcro tape was also used on the tabs at the bottom of the vest, making it easily adjustable and providing a more-secure fit. Attach hooks and loops to opposite sides of the vinyl.

As an alternative to Velcro, the target can be glued to the vest, or double-sided tape can be used to mount it. The author used a short length of lightweight speaker cable, terminated at one end with an RCA-type phono plug, to connect the targets to the electronic unit. The phono plug simply plugs into the unit, and can be quickly attached or detached. Decorative stickers were also placed on the vest. While the stickers used have an adhesive back, additional adhesive is required to permanently affix the stickers to the vest.

I'll Squirt To That

When the unit is turned on with targets dry, the green LED should flash. Also, the buzzer may go on for about four seconds when first turned on. When water hits the sensor, the buzzer should sound off for about four seconds and the red LED should flash while the target is wet. (Only one LED should flash at any one time.) Once the target dries off, the green LED should resume flashing.

If all works as it should, clip on the unit, put on the vest, and attach the targets. Plug the cable from the targets into the unit. Fill the squirt gun, and turn the unit on. The flashing green LED signals that the unit is ready for action and should respond to a “hit” on a target. Carefully approach your opponent, preferably sideways to protect your vital “target spots.” It's also wise to stay behind cover, such as a tree or bush.

Rules of the Road

It is against the official rules of Squirt-Gun Tag to purposely put one's hand or other object in front of a target to protect it from a water blast. It also is illegal to purposely unplug the target's cable. When you are “dead” (a target gets hit with a blast of water), the loud buzzer will let everyone know! While your target is still wet, the red LED will continue to flash. The flashing red LED means you have been hit

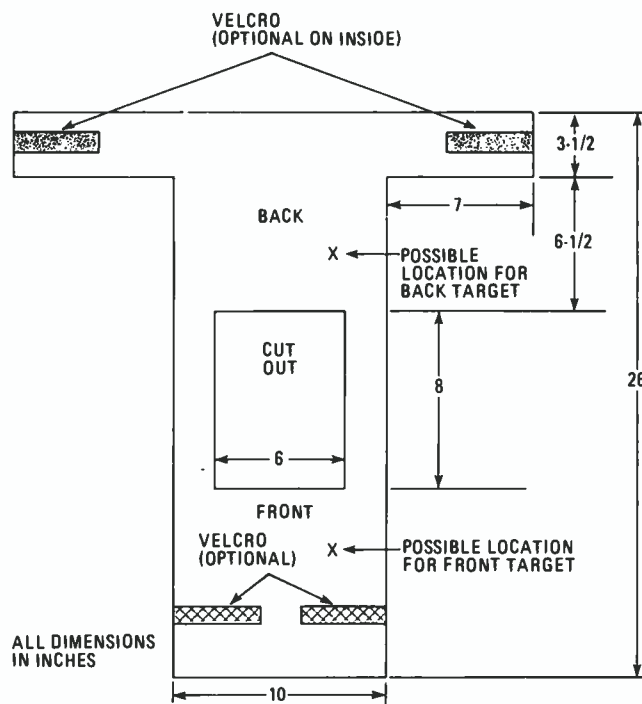

Fig. 6—The vest, whose primary function is to hold the targets, can be made from vinyl material (such as that used for tablecloths). The size of the vest should match the user. The pattern for a child 3½–5 feet tall is shown here. For a larger person, increase dimensions accordingly. The author attached the targets to the vest with Velcro tape.

by a blast of water and another hit won't cause the buzzer to go off—like you, the unit is temporarily “dead.” Notice that the unit will only respond to a hit when the green LED is flashing. The sensitivity of a particular Squirt-Gun Tag set depends upon the target. A large target with a complex conductive pattern will respond quicker and to less water than a smaller, simpler target.

It is not as easy to get “killed” (have the buzzer go off) as it may first appear. With the average target, it takes nearly a direct blast of water aimed at the center of the target. Of course, getting “killed” can also be accumulative. A number of small splashes of water will often wet the target sufficiently to set off the buzzer. One other point: playing Squirt-Gun Tag during a rainstorm often proves to be futile.

Well I better go now and fill my squirt gun. I just noticed a couple of the boys running to the sink holding squirt guns, and one of the guns was absolutely awesome! ■

THE RUBBER CRYSTAL OSCILLATOR

(Continued from page 44)

the crystal the stability very gradually decreases, while the tuning rate increases exponentially.

Construction

The great advantage of the Rubber Crystal Oscillator is that even with the type of construction shown in the photos, the circuit is very stable unless pushed to the limits of its frequency swing.

An octal tube socket is used for the crystal and a piece of 2-inch (outer diameter) plastic pipe is used for the coil form. Make small holes at each end of the pipe. Wrap 11 turns of wire around the pipe and tuck the ends through the holes. The capacitor was salvaged from an old broadcast-band set.

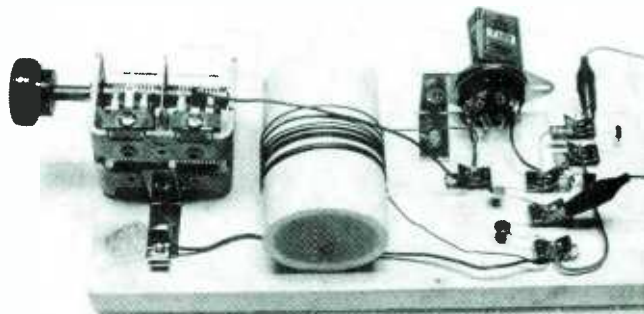

The open construction and fahnestock clips make experimentation easy. Try your own ideas and build it the way you want—it's a very uncritical and forgiving circuit.

The circuit can be used on other bands. Just use an appropriate coil and tuning capacitor with plenty of tuning range on either side of the crystal frequency. Less frequency change can be expected on lower bands, and more on the higher ones.

If you plan to stretch the rubber crystal to its limits and

need the maximum frequency swing, you should consider a metal panel and a tuning knob with a reduction drive. Otherwise, there's nothing critical about the construction. Try what parts you have on hand and use your own ideas. You might discover something new—or even why it works!

PARTS LIST—RUBBER CRYSTAL OSCILLATOR

- Q1—NPN, high-frequency, small-signal, silicon transistor
- C1—365-pF variable capacitor
- C2,C3—100-pF, 15-WVDC ceramic disc capacitor
- R1—4700-ohm, 1/2-watt, 5% resistor
- R2—470,000-ohm, 1/2-watt, 5% resistor
- L1—Coil made from 11 turns of 1-in. long, 2-in. dia., #22

- enameled wire
- XTAL1—crystal (see text)

ADDITIONAL PARTS AND MATERIALS

- Octal socket, brackets for socket and variable capacitor, knob, fahnestock clips, flathead screws, board, wire, solder, etc.

CIRCUIT CIRCUS

(Continued on page 85)

are connected in a Darlington configuration to provide increased current. If Q1 and Q2 each have a H_{fe} of 40, then the circuit's overall gain is 1600, vs. a gain of 50 for the regulator in Fig. 4. For a 10-amp output, the base current needed for Q1 would be 10/1600 or 6.25 mA. Increasing the base current to 10 mA and using a 1/2-watt, 1000-ohm resistor for R_X should do the trick. Note that with a Darlington pair in the circuit, we have two base-emitter voltage drops to subtract from the output. Therefore, a 14-volt Zener should be used.

The Easy Way

Examine the regulator circuit shown in Fig. 6. In it, a three-terminal regulator, two resistors, two capacitors,

and an unregulated-power source combine to make a 2- to 25-volt, 1.5-amp adjustable power supply.

The output voltage of that circuit is calculated using; $V_O = 1.25(1 + R2/R1)$. Maximum power dissipation for the LM317T is 15 watts, with a heat-sink. Typical load regulation is .1%.

Figure 7 illustrates how a battery can be connected to the input of a regulator

through a silicon diode, to provide backup power when AC power is interrupted. As long as the DC output from the rectifier circuit is greater than the battery voltage, no current flows through diode D1. But when the AC power fails, the battery furnishes current through D1 to operate the load until the AC comes back on line, or the battery is discharged.

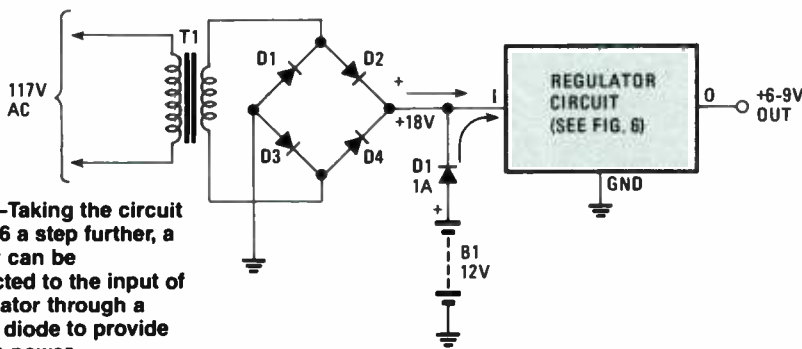

Fig. 7—Taking the circuit in Fig. 6 a step further, a battery can be connected to the input of a regulator through a silicon diode to provide backup power.



■ HERE'S THE ANSWER to that eternal question among electronics hobbyists—"What will I do?" In WELLS' THINK TANK you'll find over 53 pages jam-packed with over 130 one-evening projects that will keep you absorbed. These are tantalizing devices that you can quickly put together and then use immediately. There are projects for your car, your home, your work bench, other hobbies, such as photography, music, and stereo. Telephone projects, light controls, and a vast assortment of miscellaneous do-it-yourself items. Flipping through the pages of this book, the question becomes "Which one will I start with!"

■ THE THINK TANK originally appeared in Hands-On

Electronics Magazine, and immediately won a good deal of reader acceptance. The mail poured in as readers offered their own circuits or asked for assistance with electronics projects they worked on.

■ WHAT KIND OF PROJECTS will you find in the WELLS' THINK TANK BOOK? The index, which occupies the entire back page, lists them. Choose from nearly a dozen amplifiers, an assortment of automotive projects from automatic parking lights to electronic air horns, battery chargers to battery monitors. You'll find fuzz boxes for your guitar to a tremolo unit. A darkroom timer for your photo buffs. And at a price of only \$3.50, you can't go wrong!

THINK TANK—Circuits for Experimenters and Project Builders!

169—Please send one copy of THINK TANK at \$3.50. Shipping \$1.25 (U.S. and Canada only).

169—Please send _____ copies of THINK TANK. Total cost is sum of copy price and shipping cost multiplied by number of copies ordered.

Please print

Allow 6-8 weeks for the material to arrive.

(Name)

(Street Address)

(City)

(State)

(Zip)

Detach and mail today:
HANDS-ON ELECTRONICS
Reprint Department
500-B Bi-County Boulevard
Farmingdale, NY 11735

All Payment must be in U.S. Funds!

HB 88

THINK TANK

53 PAGES, OVER 130

PROJECTS!

SIMPLE, EASY-TO-BUILD AND
USEFUL IDEAS FOR YOUR
HOME, HOBBY, CAR.

KITES AS ANTENNAS

(Continued from page 67)

In Action

There is a certain thrill in playing games with Nature. In radio listening and communications, there are always some variables, such as time of day and sunspot activity, that we cannot control. Using kites as antenna supports adds an additional element of variability since we have no control over the wind direction and speed. Harnessing that variable requires an intimate knowledge of antenna characteristics as a function of their length. Space-perception abilities are a definite asset for the person interested in taking maximum advantage of long-wire slopers. Kite-flying skill is required to a certain extent also. For the person who can put together, in concert, his or her familiarity with radio propagation, as well as those other things, great satisfaction is waiting. There's nothing quite like snagging a really rare DX station from the teeth of a pileup, where many of the operators may be using expensive amplifiers and antenna installations.

I have worked excellent DX on the 40-meter and 80-meter amateur bands with kite-supported sloping long wires as large as 600 feet (200 meters) in length. I use only 90 watts CW output and have worked all over the world on those bands without difficulty. I get excellent signal reports much of the time.

I worked a Rumanian ship off the coast of Sierra Leone, and he sounded as though he were just a few miles away—S9 plus 20 dB on the meter of my Yaesu transceiver. The Russian beacon at 3.636 MHz is generally loud and clear at night, sending "U U U."

On 160 meters I have also worked some DX, and get very good signal reports from all over the continental United States

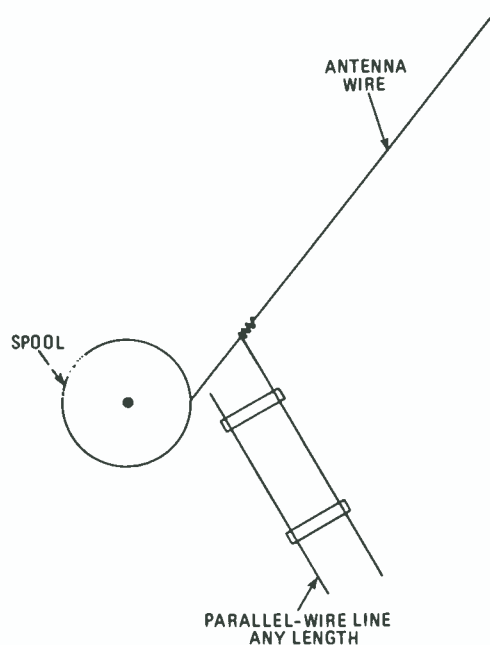

Fig. 6—Zepp-feed connection to antenna wire an integral multiple of 0.5 wavelength long. One end of the parallel-wire line is simply left free; the other is connected to the antenna wire by clip lead or twisting.

with an antenna that cost only a few dollars.

Ultimately I'd like to fly a kite-supported longwire sloper over a salt-water ground. I'd better start saving up for that tropical expedition. And for those non-hamming daylight hours, well, I still have my surfboard from Cocoa Beach!

A wide selection of kites is sold and described by the free catalog available from Into The Wind, 1408 Pearl Street, Boulder, CO 80302. ■

ELLIS ON ANTIQUE RADIO

(Continued from page 83)

All of the illustrations are beautifully reproduced, making this work a browser's delight, in addition to being a definitive reference source. *Radio Manufacturers of the 1920's, Volume 1* belongs in every serious collector's library, and we hope that it won't be long before the companion volumes are released. Published by *The Vestal Press Ltd.* (PO Box 97, Vestal, NY 13851), the book has 225 pages, and is available from them for \$29.95, hardcover; \$19.95, softcover.

Stay Tuned

Catch us next month for more on the restoration of the Zenith shutter-dial set. In the meantime, I'd enjoy hearing from you. Your comments, questions, and stories help me keep *Ellis on Antique Radio* focused on material that is of maximum interest to the readers—and make rather interesting reading themselves! I regret that I can't answer them individually. If I did that, I probably wouldn't have time to write the column. But most of those letters

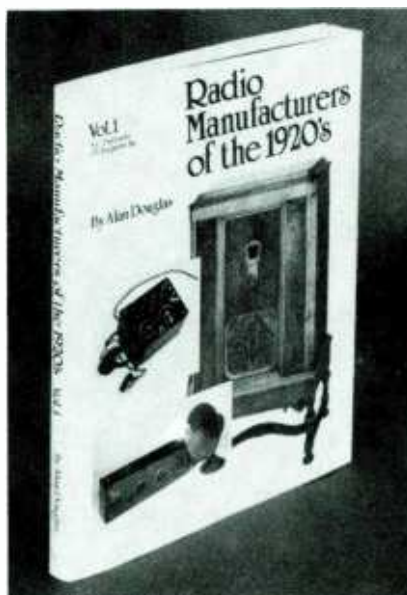

Alan Douglas' *Radio Manufacturers of the 1920's* belongs in every serious collector's library.

eventually find their way onto these pages. Write to Marc Ellis, C/O **Hands-on Electronics**, 500-B Bi-County Blvd., Farmingdale, NY 11735 ■

CARR ON HAM RADIO

(Continued from page 92)

The G5RV Multi-Band Dipole

Figure 3 shows the popular G5RV antenna. Although not without some problems, that antenna is very popular at the moment. It can be used either as a horizontal dipole, a sloper, or as an inverted-Vee antenna (which is how I used it). The dipole elements are each 51-feet long. The feedline may be either 300-ohm or 450-ohm twin-lead. For 300-ohm cases, use 29 feet of line, and for 450-ohm line use 34 feet.

One end of the parallel transmission line is connected to the antenna, while the other end is connected to a length of 50-ohm coaxial cable. Although most articles on the G5RV claim that any length of 50-ohm line will work, J.M. Haerle (*HF Antenna Systems: The Easy Way*) recommends that the 50-ohm segment be at least 65-feet long. Haerle is a little caustic in his comments on the G5RV, but his criticism is well taken.

If you don't have a parallel transmission match, then the G5RV will work (especially if your rig can tolerate a 3:1 VSWR on some selected frequencies).

Otherwise, use the antenna of Fig. 2A (or a transmatch with the G5RV).

Feeding Parallel Transmission Line

Parallel transmission line is balanced with respect to ground, while coaxial cable is unbalanced to ground (i.e. one side of the coax is usually grounded). As a result, the standard amateur-transmitter output will not drive a parallel (balanced) feedline properly. We need to do one of two things: either buy or build an antenna tuner that is balanced at the output and unbalanced at the input; or convert a standard "coax-to-

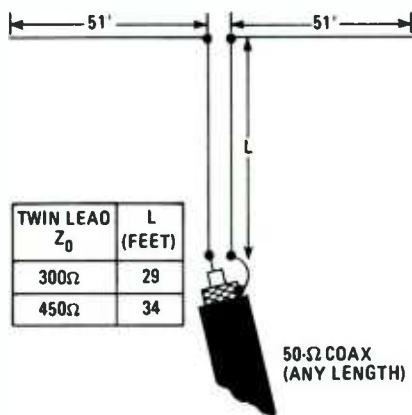

Fig. 3—The G5RV antenna, although not without some problems, is a very popular antenna at the moment. It can be used either as a horizontal dipole, a sloper, or as an inverted-Vee antenna (which is how I used it).

coax" transmatch or some other form of antenna coupler with a "coax-to-balanced" configuration.

In some cases, you can use a 4:1 balun transformer at the output of the coaxial cable tuner. Keep in mind, however, that some tuner manufacturers do not advise that practice. If you use the

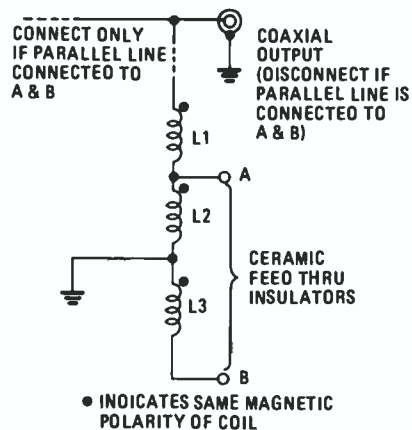

Fig. 4—A balun can be made using 12-turns of #12 enameled wire over a 1-inch diameter piece of PVC tubing.

standard "Tee-network" or SPC transmatch (see *The ARRL Antenna Book 14th Edition*, pages 4–6), then it is possible to make a balun for that purpose from some #12 enamel-covered wire and either a ferrite toroid or a short piece of PVC plumbing pipe.

Figure 4 shows a balun construction project. Use 12 turns of #12 enameled wire over a 1-inch outside-diameter piece of PVC pipe or tubing.

Material Things

Some readers have complained of not

being able to buy parts for antennas locally, so I researched some companies that sell such products by mail. The list in Table 1 is not exhaustive, but should give you a start. If you call or write any of those companies, kindly mention this column.

Well, we've once again come to the point where we have to say so-long. But, in the meantime, if you have any comments, suggestions, or questions pertaining ham radio, send your correspondences to Joe Carr, K4IPV, PO Box 1099, Falls Church, VA 22041. ■

Hands-on Electronics

REPRINT BOOKSTORE

- | | |
|---|---|
| <input type="checkbox"/> SP1 Special Projects #1 (Winter 1980) ... \$6.00 | <input type="checkbox"/> 106 Radio-Electronics back issues (1986) ... \$3.75 |
| <input type="checkbox"/> SP4 Special Projects #4 (Summer 1982) ... \$6.00 | Write in issues desired |
| <input type="checkbox"/> SP5 Special Projects #5 (Winter 1983) ... \$6.00 | <input type="checkbox"/> 105 Radio-Electronics back issues (1985) ... \$4.25 |
| <input type="checkbox"/> SP6 Special Projects #6 (Spring 1983) ... \$6.00 | (Jan. 85 not available) |
| <input type="checkbox"/> SP7 Special Projects #7 (Summer 1983) ... \$6.00 | Write in issues desired |
| <input type="checkbox"/> SP8 Special Projects #8 (Fall 1983) ... \$6.00 | <input type="checkbox"/> 104 Radio-Electronics back issues (1984) ... \$5.25 |
| <input type="checkbox"/> SP9 Special Projects #9 (Winter 1984) ... \$6.00 | (December 1984 issue is not available) |
| <input type="checkbox"/> SP10 Special Projects #10 (Spring 1984) ... \$6.00 | Write in issues desired |
| <input type="checkbox"/> 111 Hands-On Electronics #1 ... \$5.00 | <input type="checkbox"/> 103 Radio-Electronics back issues (1983) ... \$5.50 |
| <input type="checkbox"/> 112 Hands-On Electronics #2 ... \$5.00 | (Jan., Feb., May are not available) |
| <input type="checkbox"/> 113 Hands-On Electronics #3 ... \$5.00 | Write in issues desired |
| <input type="checkbox"/> 114 Hands-On Electronics #4 ... \$5.00 | <input type="checkbox"/> 102 Radio-Electronics back issues (1982) ... \$5.75 |
| <input type="checkbox"/> 115 Hands-On Electronics #5 ... \$5.00 | (Jan., Feb.) is not available |
| <input type="checkbox"/> 115A Hands-On Electronics #6 ... \$4.50 | Write in issues desired |
| <input type="checkbox"/> 116A Hands-On Electronics (Jan-Feb '86) ... \$4.50 | <input type="checkbox"/> 153 Etch your own PC boards ... \$3.00 |
| <input type="checkbox"/> 116B Hands-On Electronics (Mar/Apr '86) ... \$4.50 | <input type="checkbox"/> 154 How to Repair VCR's ... \$3.50 |
| <input type="checkbox"/> 116C Hands-On Electronics (May/Jun '86) ... \$4.50 | <input type="checkbox"/> 155 IBM Typewriter to Computer ... \$3.00 |
| <input type="checkbox"/> 116D Hands-On Electronics (Jul/Aug '86) ... \$4.50 | <input type="checkbox"/> 125 Radio-Electronics Annual 1985 ... \$5.95 |
| <input type="checkbox"/> 116E Hands-On Electronics (Sep/Oct '86) ... \$4.50 | <input type="checkbox"/> 126 Radio-Electronics Annual 1986 ... \$4.95 |
| <input type="checkbox"/> 116K Hands-On Electronics (Nov '86) ... \$4.00 | <input type="checkbox"/> 156 How to Make PC Boards ... \$2.00 |
| <input type="checkbox"/> 116L Hands-On Electronics (Dec '86) ... \$4.00 | <input type="checkbox"/> 157 All About Kits ... \$2.00 |
| <input type="checkbox"/> 117 Hands-On Electronics (1987 back issues) ... \$3.75 | <input type="checkbox"/> 158 Electro Importing Co. Catalog (1918) ... \$5.95 |
| Write in issues desired | <input type="checkbox"/> 159 Low Frequency Receiving Techniques Building and using VLF Antennas ... \$6.00 |
| <input type="checkbox"/> 118 Hands-On Electronics (1988 back issues) ... \$3.50 | <input type="checkbox"/> 160 New Ideas - 42 Circuits ... \$3.50 |
| Write in issues desired | <input type="checkbox"/> 161 Descrambling (Feb., 1984) ... \$3.00 |
| <input type="checkbox"/> 150 TV Descrambler ... \$3.00 | <input type="checkbox"/> 162 Build Your Own Satellite TV Receiver \$7.00 |
| <input type="checkbox"/> EH87 Experimenters Handbook ... \$3.95 | <input type="checkbox"/> 163 Receiving Satellite TV ... \$7.00 |
| <input type="checkbox"/> 152 8-Ball Satellite TV Antenna ... \$5.00 | <input type="checkbox"/> 164 Modern Electrics (April, 1988) ... \$3.00 |
| <input type="checkbox"/> 108 Radio-Electronics (1988 back issues) ... \$3.00 | <input type="checkbox"/> 165 How to Repair CD Disc Players ... \$5.00 |
| Write in issues desired | <input type="checkbox"/> 166 Collected Works of Mohammed Ulysses Fips (62 pages, April Fools Collection) ... \$7.50 |
| <input type="checkbox"/> 107 Radio-Electronics back issues (1987) \$3.25 | <input type="checkbox"/> 167 Designing With IC's ... \$4.00 |

To order any of the items indicated above, check off the ones you want. Complete the order form below. Include your payment, check or money order (DO NOT SEND CASH), and mail to Hands-on-Electronics, Reprint Department, P.O. Box 4079, Farmingdale, NY 11735. Please allow 4-6 weeks for delivery.

If you need a copy of an article that is in an issue we indicate is unavailable you can order it directly from us. We charge 50¢ per page. Indicate the issue (month & year), pages and article desired. Include payment in full, plus shipping and handling charge. Make checks payable to Gernsback Publications, Inc.

ARTICLE	MONTH	YEAR
PAGES		
TOTAL PAGES	@50¢ each	TOTAL PRICE

MAIL TO: Hands-on-Electronics
Reprint Bookstore, P.O. Box 4079, Farmingdale NY 11735

SHIPPING CHARGES IN USA & CANADA

\$0.01 to \$5.00	\$1.25	\$30.01 to \$40.00	\$5.00
\$5.01 to 10.00	\$2.00	\$40.01 to \$50.00	\$6.00
\$10.01 to \$20.00	\$3.00	\$50.01 and above	\$7.50
\$20.01 to \$30.00	\$4.00		

Total price of merchandise \$ _____

Sales Tax (New York State Residents only) \$ _____

Shipping Charge (see chart) \$ _____

Name _____ Total Enclosed \$ _____

Address _____

City _____ State _____ Zip _____

H9-88

PORTABLE ELECTRONICS WORKBENCH

(Continued from page 34)

Portable Electronics Workbench when the unit is completed. Let's get to that next.

I mounted two 12-inch lengths of $\frac{5}{8}$ -inch diameter dowel to accommodate eight small reels of hookup wire. Each reel that I purchased has 75 feet of hookup wire. I bought stranded and solid copper wire with different insulation colors.

Fit four decent-sized rubber feet to the underside of the workbench so that the bench does not scratch or move around on the table.

I also fitted an AC power strip consisting of four three-prong outlets and a power switch to the right side of the workbench to provide power for a soldering iron, low-voltage regulated DC power supply, power projects, and so on. A master switch is used to power down during coffee breaks.

A set of parts-storage drawers can also be set in place next to the reels of wire using screws or double-sided tape. Be sure to purchase something that will fit in the recess under the top shelf of the workbench.

You'll also want a set of spring clips to hold your most-often used hand tools, such as screwdrivers, pliers, and side-cutters. Visit your local hardware/housewares outlet rather

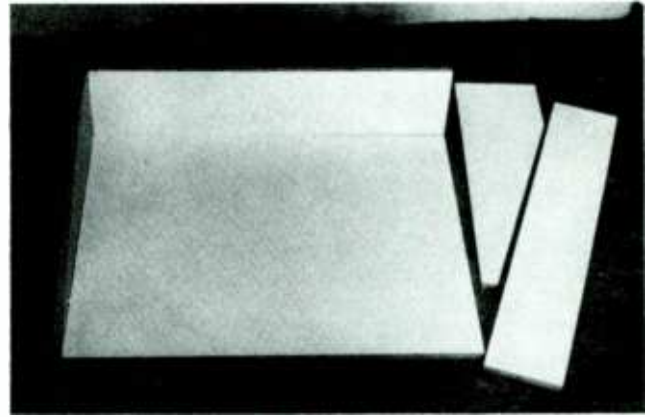

Here is the workbench partially assembled. The right-side wall and top shelf piece are yet to be set in place by wood screws.

than try to find a particular product type. Also consider installing a magnetic tool holder.

As you can see, the final workbench is a portable beauty. You can set it up on a tabletop at a moment's notice and resume your project assembly almost immediately. I wonder why I didn't put together a Portable Electronics Workbench years ago? ■

BOOKSHELF

(Continued from page 27)

Understanding Automotive Electronics, Third Edition

By William B. Ribbens, Ph.D.

As automotive technology becomes more sophisticated, routine car maintenance and repair becomes more difficult. *Understanding Automotive Electronics* teaches how the electronic systems function—in the cars we own now, and in those we'll be purchasing in the future. The material is presented in a straightforward manner, and is rein-

Understanding
Automotive
E



CIRCLE 95 ON FREE INFORMATION CARD

Microcomputer instrumentation and control, sensor and actuator technology, digital engine-control systems, motion control, and automotive instrumentation are covered in detail. The chapter on diagnostics explores innovative automotive diagnostic practices for microprocessor-based electronic engine and instrument controls. It concludes with a section on future automotive-electronics systems, including tried and untried systems for drivetrain, safety, and instrumentation. It takes a look at new ideas such as distributorless ignition, torque-converter lockup, radar, CRTs, and speech synthesis.

Understanding Automotive Electronics contains 366 pages, and costs \$17.95 from Howard W. Sams & Company, 4300 West 62nd St., Indianapolis, IN 46268; Tel. 800-428-SAMS.

Puzzles, Paradoxes and Brain Teasers

By Stan Gibilisco

It was once believed that the mathematical universe was perfect. The fact that it is not results in some interesting contradictions, puzzles, and paradoxes. In this book, Stan Gibilisco gives readers an intriguing look at those exceptions to the logical world of mathematics.

Puzzles, Paradoxes and Brain Teasers is written in an entertaining, easy-to-understand style. Although advanced mathematical topics are covered, the

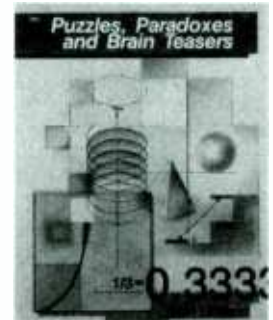

CIRCLE 98 ON FREE INFORMATION CARD

discussions are non-technical, and require no more than high school-level math and the ability to think clearly.

The book begins with some classic puzzles, such as the "Frog and the Wall" problem, which dates back to the ancient Greeks, and "toothpick" games, in which sticks are rearranged to form different shapes. Logic and valid argumentation are then discussed, as an introduction to logical paradoxes.

Following chapters cover limits, including the concept of upper and lower bounds; mathematical universes; relativity—examining black holes, time travel, and how time "slows down" as speed increases; and the concept of infinity. The book concludes with a look at some strange cosmological, astrophysical, and quantum-mechanical phenomena.

Puzzles, Paradoxes and Brain Teasers (order No. 2895) contains 111 pages, and is available in softcover for \$8.70

forced by illustrations, self-quizzes, and a glossary.

The book contains automotive fundamentals, electronics fundamentals, and the applications of electronics to automotive functions. Prior knowledge and experience in electronics or car repair are not needed to understand the text.

and in hardcover for \$14.95 from Tab Books Inc., Blue Ridge Summit, PA 17294-0850; Tel. 1-800-233-1128.

Introducing Digital Audio By Ian R. Sinclair

Digital recording is not a new technology. It's been around for years in professional recording studios, but the compact disc was the first device to bring digital audio to the home. Now that CDs are an established media, and Digital Audio Tape (DAT) systems are on the horizon, digital equipment for consumers is becoming quite common.

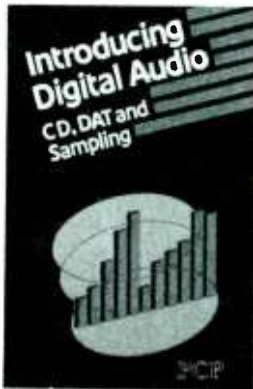

CIRCLE 97 ON FREE INFORMATION CARD

Digital-audio technology, however, bears little resemblance to the traditional methods and linear circuits of the past. Its principles and practices are more comprehensible to computer engineers than to traditional audio technicians. *Introducing Digital Audio* is intended to bridge that gap of understanding for technicians and amateurs. Principles and methods are explained, but mathematical background and theory is avoided, other than to state the end product.

The book begins with the basics of digital circuitry, discussing digital principles and such devices as gates, sequential circuits, CMOS and memory ICs, registers, and microprocessors. Analog-to-digital and digital-to-analog conversions, and digital-recording methods in the studio are examined.

Introducing Digital Audio (order No. PCP102) has 103 pages, and costs \$11.95, including shipping, from Electronics Technology Today, P.O. Box 240, Massapequa, NY 11762.

Experiments in Artificial Neural Networks By Ed Rietman

Like the biological networks of brain-nerve cells, the electronic circuits in neural networks use associative memory to cope with "messy" data. Those cir-

cuits can collect scattered facts and remember from incomplete details, similar to the way the human brain stores and retrieves information. The result is a "thinking" computer with the ability to learn.

Experiments in Artificial Neural Networks explores the possibilities of using threshold-logic circuits and com-

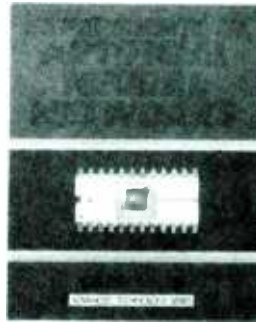

CIRCLE 98 ON FREE INFORMATION CARD

puter software to simulate the information-processing methods of the brain's neural systems. The book is an introduction to parallel-distribution processing—the matching of the parallel structure of neurons using hardware/software implementation—with threshold devices.

The limitations of today's computers are discussed, and different types of parallel-processing computers, including artificial-neural networks, are presented. The book introduces the mathematics and theory of parallel-distributed processing, and presents many examples. Digital-computer simulations of artificial-neural networks are developed, based on that theory and mathematics. Detailed schematics are provided for the construction of six neural-network circuits. Those circuits are stand-alone and PC-interfaced units. Finally, the author takes a look at the future of artificial intelligence, and those corporations involved in its research and development.

The book is intended to open new avenues of experimentation for computer enthusiasts and researchers in artificial intelligence. Some background in algebra, and experience with personal computing, is required for understanding. To build the neural-networking breadboards, the reader should also have knowledge of circuit construction, wire-wrapping, breadboarding, and basic electronics terminology.

Experiments in Artificial Neural Networks (order No. 3037) contains 144 pages, including appendices. It is available for \$16.60 in paperback, and \$24.95 in hardcover, from Tab Books Inc., Blue Ridge Summit, PA 17294-0850; Tel. 1-800-233-1128.

NEW FROM ETT



RATCHET — ELEVEN-PIECE RATCHET TOOL KIT.....\$10.00. Includes reversible ratchet handle, extension bar, six bits, two precision screwdrivers, and a cutter. Comes in fitted case. Get one for your shop, another for your car, another for your tool kit.

TOOL KIT—NINE-PIECE TOOL KIT.....\$9.50. Includes saw, bubble level, three screwdrivers, torque multiplier, calipers for inside and outside measurements, nippers, and a tape measure.



BP233—ELECTRONIC HOBBYISTS HANDBOOK.....\$7.95. Provides an inexpensive single source of easily located data that the electronics enthusiast is likely to need in his day-to-day hobby activities. 8 x 10 inches.

BP232—CONCISE INTRODUCTION TO MS-DOS.....\$5.95. If you are a PC user and want to get the most out of your computer, you must learn its MS/PC-DOS operating system. That's what this book shows you.



BP194—MODERN OPTO DEVICE PROJECTS.....\$6.25. Provides a number of practical designs that use opto-electronic devices such as fiber optics, LEDs, and passive IR detectors.

BP234—TRANSISTOR SELECTOR GUIDE.....\$10.00. Prepared from a vast database of specifications. Unique guide offers a wide range of selection tables. More than 1400 devices are listed along with specs.



MAIL TO: **Electronic Technology Today Inc.**
P.O. Box 240
Massapequa Park, NY 11762-0240

SHIPPING CHARGES IN USA AND CANADA

\$0.01 to \$5.00	... \$1.25	\$30.01 to \$40.00	\$5.00
\$5.01 to 10.00	... \$2.00	\$40.01 to \$50.00	\$6.00
\$10.01 to 20.00	\$3.00	\$50.01 and above	\$7.50
\$20.01 to 30.00	\$4.00		

SORRY, No orders accepted outside of USA and Canada

Total price of merchandise \$ _____
Shipping (see chart) \$ _____
Subtotal \$ _____
Sales Tax (NYS only) \$ _____
Total Enclosed \$ _____

Name _____
Address _____
City _____ State _____ Zip _____

HANDS-ON MARKETPLACE

FOR SALE

TRANSISTORS—tubes: MRF421 \$24.00, MRF454 \$14.50, MRF455-MRF477 \$11.75, MRF492 \$16.00, SRF2072 \$12.75, SRF3800 \$17.50, 2SC2290 \$16.75, 2SC2879 \$22.00, 6LF6, 6LQ6, 6JS6, 8950, etc.—call. New RANGER AR3500 all mode 10 meter transceiver \$319. Quantity discounts! Best prices on hard-to-find parts, antennas, mics, power supplies, & equipment! Catalog \$1.00 (refundable), or free with order. RFPC, Box 700, San Marcos, CA 92069. For information or same day shipment—call (619) 744-0728. Visa/MC/C.O.D.

CABLE TV converter/descramblers—wholesale quantity pricing—original factory equipment—Zenith Z-TAC, Pioneer, Oak Total Control, Scientific Atlantic, Jerrold, Tocom VIP/SC; also remotes, kits, and more. This month's special—Jerrold 400 Combo w/remote—\$109.00 (add \$5.00 S/H). Free catalog. ARIZONA VIDEO, 3661 N. Campbell, Suite 310, Tucson, AZ 85719. (602) 323-3330.

THE invention of television. Fascinating story of how radio, motion pictures, and television were invented. 144 pages. 45 rare photos. Send \$10.00 ck/MO. BELLTOWNE PUBLISHING, 10011 Belltowne, Sugarland, TX 77478.

Cable TV Converters

Why Pay A High Monthly Fee?

Jerrold Products include "New Jerrold Tri-Mode," SB-3. Hamlin, Oak VN-12, M-35-B, Zenith, Magnavox, Scientific Atlanta, and more. (Quantity discounts) 60 day warranty. For fast service C.O.D. orders accepted. Send SASE (60 cents postage) or call for info (312) 658-5320. **MIDWEST ELECTRONICS, INC.,** 5143-H W. Diversey, Chicago, IL 60639. MC/Visa orders accepted. No Illinois orders accepted. Mon.-Fri. 8 A.M.-5 P.M. CST

TUBES 59¢. Year guarantee. Free catalog. Tube tester \$8.95. CORNELL, 4219 University, San Diego, CA 92105.

NICD battery replacements: hard to find cells & packs for radios, scanners, others. Send SASE for quotes. CUNARD ASSOCIATES, Dept. E, R.D. 6 Box 104, Bedford, PA 15522.

CABLE TV equipment S.A., Jerrold, Zenith, Hamlin, Oak Eagle filters remotes and more. Best prices C.O.D.'s accepted dealers needed. Ours work where others failed and we guarantee it! TRANS-WORLD CABLE, CO., 1-(800) 442-9333.

SAVE/make \$1000's high technology insider secrets catalog \$2.00 exotic parts; LEEWARE, Box 5636, Greensboro, NC 27435.

PLANS/KITS

BUILD this five-digit panel meter and square wave generator including an ohms, capacitance and frequency meter. Detailed instructions \$2.50. BAGNALL ELECTRONICS, 179 May, Fairfield, CT 06430.

VOICE disguisers! FM bugs! Telephone transmitters! Phone snoops! More! Catalog \$1.00 (refundable); XANDI ELECTRONICS, Box 25647, 32S, Tempe, AZ 85282.

PC boards made to order. Details—SASE. Eprom programmer plans. \$3.50 includes semiconductor bonus! GALLIUM JUNCTION, 540-C N.E. Northgate Way, Suite 542, Seattle, WA 98125.

PRINTED circuit boards drilled & etched. Free delivery. **K & F ELECTRONICS INC.,** 33041 Groesbeck, Fraser, MI 48026, (313) 294-8720.

SURVEILLANCE electronics, debugging, kits latest high-tech. Catalog \$2.00. **TECHNOLOGY SERVICES,** 829 Ginette Street, Gretna, LA 70056.

CLASSIFIED AD ORDER FORM

To run your own classified ad, put one word on each of the lines below and send this form along with your check to:

Hands-on-Electronics Classified Ads, 500-B Bi-County Boulevard, Farmingdale, N.Y. 11735

PLEASE INDICATE in which category of classified advertising you wish your ad to appear. For special headings, there is a surcharge of \$10.00.

() Plans/Kits () Business Opportunities () For Sale
() Education/Instruction () Wanted () Satellite Television
() _____

Special Category: \$10.00

PLEASE PRINT EACH WORD SEPARATELY, IN BLOCK LETTERS.

(No refunds or credits for typesetting errors can be made unless you clearly print or type your copy.) Rates indicated are for standard style classified ads only. See below for additional charges for special ads. **Minimum: 15 words.**

1	2	3	4	5
6	7	8	9	10
11	12	13	14	15 (\$21.00)
16 (\$22.40)	17 (\$23.80)	18 (\$25.20)	19 (\$26.60)	20 (\$28.00)
21 (\$29.40)	22 (\$20.80)	23 (\$32.20)	24 (\$33.60)	25 (\$35.00)
26 (\$36.40)	27 (\$37.80)	28 (\$39.20)	29 (\$40.60)	30 (\$42.00)
31 (\$43.40)	32 (\$44.80)	33 (\$46.20)	34 (\$47.60)	35 (\$49.00)

We accept MasterCard and Visa for payment of orders. If you wish to use your credit card to pay for your ad fill in the following additional information (Sorry, no telephone orders can be accepted.):

Card Number _____

Expiration Date _____

PRINT NAME _____

SIGNATURE _____

IF YOU USE A BOX NUMBER YOU MUST INCLUDE YOUR PERMANENT ADDRESS AND PHONE NUMBER FOR OUR FILES. ADS SUBMITTED WITHOUT THIS INFORMATION WILL NOT BE ACCEPTED.

CLASSIFIED COMMERCIAL RATE: (for firms or individuals offering commercial products or services) \$1.40 per word prepaid (no charge for ZIP code)...**MINIMUM 15 WORDS.** 5% discount for same ad in 6 issues within one year; 10% discount for 12 issues within one year if prepaid. **NON-COMMERCIAL RATE:** (for individuals who want to buy or sell a personal item) \$1.15 per word, prepaid...no minimum. **ONLY FIRST WORD AND NAME** set in bold caps at no extra charge. Additional bold face (not available as all caps) 25¢ per word additional. Entire ad in boldface, \$1.70 per word. **TINT SCREEN BEHIND ENTIRE AD:** \$1.75 per word. **TINT SCREEN BEHIND ENTIRE AD PLUS ALL BOLD FACE AD:** \$2.05 per word. **EXPANDED TYPE AD:** \$1.85 per word prepaid. Entire ad in boldface, \$2.20 per word. **TINT SCREEN BEHIND ENTIRE EXPANDED TYPE AD:** \$2.30 per word. **TINT SCREEN BEHIND ENTIRE EXPANDED TYPE AD PLUS ALL BOLD FACE AD:** \$2.70 per word. **DISPLAY ADS:** 1" x 2 1/4"—\$175.00; 2" x 2 1/4"—\$350.00; 3" x 2 1/4"—\$525.00. **General Information:** Frequency rates and prepayment discounts are available. **ALL COPY SUBJECT TO PUBLISHERS APPROVAL. ADVERTISEMENTS USING P.O. BOX ADDRESS WILL NOT BE ACCEPTED UNTIL ADVERTISER SUPPLIES PUBLISHER WITH PERMANENT ADDRESS AND PHONE NUMBER.** Copy to be in our hands on the 18th of the third month preceding the date of issue (i.e.; Aug. issue copy must be received by May 18th). When normal closing date falls on Saturday, Sunday or Holiday, issue closes on preceding work day. Send for the classified brochure. Circle Number 49 on the Free Information Card.

CATALOG: hobby/broadcasting/HAM/CB: Cable TV, transmitters, amplifiers, bugging devices, computers, more! PANAXIS, Box 130-F(9), Paradise, CA 95967.

CRYSTAL radio sets, plans, parts, kits. Catalog \$1.00. MIDCO, 660 North Dixie Highway, Hollywood, FL 33020.

PROJECTION-TV...Convert your TV to project 7 foot picture...Results comparable to \$2,500.00 projectors... Total cost less than \$30.00..Plans and 8" lens...\$24.95...Professional systems available...Illustrated catalog free...**MACROCOMA** 15HA Main Street, Washington Crossing, PA 18977, Creditcard orders 24 hours. (215) 736-3979.

KITS*parts*plans*. We have hard to find parts! Variable tuning capacitors, tuning coils, crystal headphones, germanium diodes, shortwave, crystal, CB radio kits (no soldering). Very inexpensive. Send large SASE for catalog.**YEARY COMMUNICATIONS**, 12922 Harbor #800H, Garden Grove, CA 92640.

BUILD yourself complete electronic dashboards, for any car. Instruction manual: \$15, details free. **MODERN LABS**, dept. M6, 2900 Ruisseau, St. Elizabeth, QC, J0K2J0, Canada.

"007" type electronics. Super surveillance. Amazing prices. Catalog \$2.00. **JD's ELECTRONICS**, Dept. Q, Box 9042, Wichita, KS 67277.

TUBES - 2000 TYPES DISCOUNT PRICES!
Early, hard-to-find, and modern tubes. Also transformers, capacitors and parts for tube equipment. Send \$2.00 for 20 page wholesale catalog.



ANTIQUE ELECTRONIC SUPPLY
688 W. First St. • Tempe, AZ 85281 • 602/894-9503

SATELLITE TV

FREE catalog systems, upgrades, Houston, Uniden, Chaparral, etc. Save \$\$\$\$ **SKYVISION**, 2008 Collegeway, Fergus Falls, MN 56537. (218) 739-5231.

CABLE descrambler liquidation. Major makes and models available. Industry pricing! (Example: Hamlin Combo's, \$44 each...minimum 10 orders). **Dealers only!** Call **WEST COAST ELECTRONICS**, (818) 989-0890.

BUSINESS OPPORTUNITIES

YOUR own radio station! AM, FM, TV, cable. Licensed/unlicensed. **BROADCASTING**, Box 130-F(9), Paradise, CA 95967.

MAKE \$250,000 yearly in IBM's computer color monitor repairs, details \$1.00. **RANDALL**, Data Display Products, Box 2168 H, Van Nuys, CA 91404.

CABLE EQUIPMENT

CABLE TV secrets—the outlaw publication the cable companies tried to ban. HBO, movie channel, Showtime, descramblers, converters, etc. Suppliers list included. \$8.95. **CABLE FACTS**, Box 711-H, Pataskala, OH 43062.

COMPUTERS

COMMODORE/Amiga chips, factory fresh and guaranteed. Lowest prices in the country, including impossible to obtain spare parts and diagnostics. "The Commodore Diagnostician," (7,000 sold—\$6.95 plus \$1.00 postage). **KASARA MICRO-SYSTEMS INC.**, 31 Murray Hill Drive, Spring Valley, NY 10977. 1-(800) 248-2983 or (914) 356-3131.

MASTERCARD AND VISA are now accepted for payment of your advertising. Simply complete the form on this page of the Market Center and we will bill you.

EDUCATION & INSTRUCTION

ENGINEERING software for IBM-PC. CompDes—circuit design, CompMath—mathematics, CompView—waveform viewer. \$49 each. (614) 491-0832. **BSOFT SOFTWARE**, 444 Colton Road, Columbus, OH 43207.

WANTED

IDEAS, inventions, new products wanted! Call free 1-(800) 288-IDEA. **ISC-HOE**, 903 Liberty, Pittsburgh, PA 15222.

For 25 years,
our people have
endured long hours
and tough
working conditions
for no pay.



And 9 out of 10 would
do it again.

TO FIND OUT WHY
call
(316) 263-2100
or write
REACT INTERNATIONAL, INC.
242 Cleveland
Wichita, KS 67214



Support America's colleges. Because college is more than a place where young people are preparing for their future. It's where *America* — and American business — is preparing for its future.

Give to
the college of
your choice.

ADVERTISING INDEX

HANDS-ON ELECTRONICS magazine does not assume any responsibility for errors that may appear in the index below.

Free Information No.	Page
6	AMC Sales 12
5	All Electronics 25
—	Amazing Devices 16
20	American Reliance 23
—	Antique Electronic Supply 105
8	CIE 11
17	Chemtronics 18
—	Command Productions 16
10	Cook's Institute 22
11	Digi-Key CV2
—	Elec. Industry Association ... CV3
—	Electronic Tech. Today CV4
—	Electronic Tech. Today ... 28, 103
—	Electronics Book Club 3
16	Emco 22
12	Fluke Manufacturing 17
—	Graham Col. of Engineering . 27
9	Halted Specialties 25
—	Hands-On Bookstore 101
—	Heath 15
15, 19	JDR Microdevices 6, 7
14	MCM Electronics 13
18	Mark V Electronics 12
—	Midwest Electronics 104
13	Mouser 18
—	NRI 21
—	Pacific Cable 5
—	REACT 105

ADVERTISING SALES OFFICE

Gernsback Publications, Inc.
500-B Bi-County Blvd.
Farmingdale, NY 11735
(516) 293-3000
President: Larry Steckler
Vice President: Cathy Steckler

For Advertising ONLY
516-293-3000

Larry Steckler
publisher
Arline Fishman
advertising director
Christina Estrada
advertising assistant
Shelli Weinman
advertising associate
Lisa Strassman
credit manager

SALES OFFICES

EAST/SOUTHEAST
Becky Akers
Pattis/3M
310 Madison Ave., Suite 1804
New York, NY 10017
212-953-2121

MIDWEST/PACIFIC
Joe Shere
1507 Bonnie Doone Terrace
Corona Del Mar, CA 92625
714-760-8697

5 CLASSIC ANTENNAS

(Continued from page 43)

beside your receiver on the desk itself! That allows you, while listening to the receiver, to reach over and rotate the antenna in order to obtain the best directional results. On the other hand, the small size of the antenna means that it's less sensitive (*i.e.*, it has less gain) than the random-length, dipole, or quarter-wave antennas.

That lack of sensitivity can be overcome by the use of an RF amplifier with the loop antenna, although many such antennas are used without amplification and give good results.

Active Antennas

Not everyone who wants an antenna for general all-band use has the space to mount an outdoor antenna, such as the random-length type. In that case, you may want to consider the active antenna (Fig. 5). As with the vertical antenna, this type has a non-directional reception pattern. The active antenna uses a very short whip (usually five feet or less) as a pick-up element. Because the signal from so short an element is very weak, a high-gain amplifier is built into the antenna's mounting base.

Active antennas are used for frequencies ranging from 100 kilohertz to 30 megahertz and, in many cases, perform as well as antennas a few hundred feet long! Some active antennas can be a bit on the noisy side—due to signal overload or intermodulation distortion—when compared to a wire antenna, but most of them can still provide a great deal of enjoyable listening. Because active antennas are sensitive to overload from strong signals, some means of reducing the input is usually included in the design.

For instance, if you notice signs of intermodulation, you can reduce input by shortening the telescoping antenna. If you can't, or don't want to put up a random-length antenna for general all-band listening, the active antenna is a viable alternative. Figure 5 shows a schematic diagram of a simple active antenna. While the circuit shown is not up to the performance levels obtained from most commercially manufactured units, it gives a surprisingly good account of itself. (Its performance is probably comparable to that of a random-length antenna 40- to 50-feet in length.)

Some General Rules

Whatever antenna you use, there are a few general rules that can help you to get good results. First, avoid contact or close proximity to power lines. People have been electrocuted when their antennas broke or slipped and contacted the high-voltage of a power line that was too close. Lightning protection is also essential if you live in an area where lightning can be a problem. And it is a good practice to disconnect your outdoor antenna when it's not in use. A switch that grounds the antenna, in addition to disconnecting it, is a good safety feature.

If your antenna requires the use of coaxial cable, use only cable that's in good condition. If you have some coax already on hand, use it and see how it performs. But evaluate its performance against a line you know to be good, if possible. Coax isn't too often a problem on the shortwave or AM broadcast band, but at VHF and UHF frequencies, bad coax can seriously attenuate your antenna's output.

The wire used for the antenna itself can be of any thickness, as long as it's of sufficient tensile strength to hold up

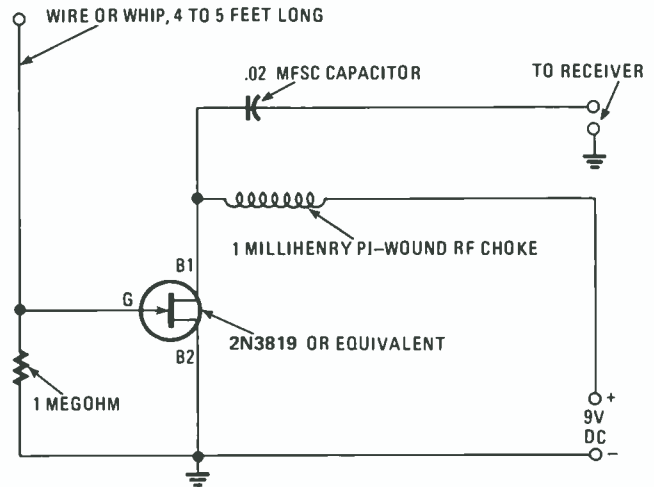

Fig. 5—The active antenna is a good choice where antenna design is hampered by space limitations. As with the vertical antenna, the active type has a non-directional reception pattern. But because the pick-up element of the active antenna is a very short whip (resulting in an extremely weak signal being delivered to the receiver), a high-gain amplifier is built into the antenna.

under adverse workloads and atmospheric conditions. Even rather thin wire seems to work very well if it's strong enough to withstand the strain that's likely to be placed on it. Copper wire is preferred. Copper-clad mild-steel is more durable, but harder to work with (and I don't like it).

Aluminum wire is also used in antennas. Galvanized clothesline wire, or even stranded cable are usually OK, if you don't have copper or aluminum. And enameled wire resists corrosion better than the bare stuff. Whatever you use, be sure to make good electrical connections, soldering where possible. Radio Shack, and most other radio-parts supply houses, stock antenna wire, insulators, lightning protectors, and lead-in cable.

A Parting of the Ways

There are advantages and disadvantages to each of the Big Five Antennas. As a matter of fact, many radio listening-enthusiasts have more than one type of antenna, and use each one of them as their needs dictate. Used in the applications where they perform best, the antennas can give a very good account of themselves indeed! For more information on selecting or building antennas, check the references listed in the sidebar. Those books are available at many radio-parts supply houses. ■

A Louis Harris Poll showed that 80% of managers interviewed said workers with disabilities were equal to or more productive than other workers! That gives new meaning to the term "able bodied."

A Disability Can Be An Asset.



The Electronic Industries Association/Consumer Electronics Group has recently completed the first in a series of videocassette training tapes.

EIA/CEG ANNOUNCES COMPLETION OF NEW "BASIC CAR AUDIO INSTALLATION" VIDEO TAPE

If you are thinking of "cashing in" on the profits in the ever growing car audio service business, the troubleshooting—service—installation—and removal of car audio products is a large, non-competitive profit center for your service facility. This thirty minute video introduces you to the ever increasing complex world of car stereo installation. It guides the new installer or owner in the correct layout and design of a car stereo installa-

tion facility, covering basic as well as specialized tools needed for the installation business.

This informative videotape is also an excellent aid to the electronics technician in that it gives the correct procedure for removing and replacing "any" car radio from the dashboard of any car and shows the installer's, salesperson's and customer's role in the installation and sale of car audio products.

KEY TOPICS COVERED IN THIS VIDEO

- The design and layout of a car stereo installation center.
- Basic and specialized tools needed for car audio installation work.
- Safety in the shop.
- How to treat the customer's car, from pre-installation checkout to demonstrating to the customer the completed job.
- The proper procedure



- for installing car audio equipment.
- The technical resources available for information about specific types of vehicles, dashboard dismantling, speaker sizes and antenna locations.
- Speaker wiring types found in the automobile. Common and floating ground systems—how to differentiate. Proper wiring procedures used in the car.

The cost of the videocassette is \$30.00. Use the order form below to order yours now!

Send to: EIA/CEG, Department PS, P.O. Box 19100, Washington, D.C. 20036

ORDER FORM

Basic Car Audio Installation	Quantity	Amount	Total Enclosed
Videocassette	_____	\$30.00 each	_____
VHS <input type="checkbox"/> BETA <input type="checkbox"/>			

Name																		
Title																		
Firm																		
Address																		
City											State			Zip				

Electronics Paperback Books

GREAT PAPERBACKS AT SPECIAL PRICES



BP173—COMPUTER MUSIC PROJECTS \$6.95. Shows how to use your home computer to produce electronic music. Many circuits. Mostly jargon free.



BP176—TV DXING FOR THE ENTHUSIAST..... \$6.95. Practical, authoritative intro to this unusual aspect of electronics. 8 1/2 x 11 in. 144 pp.



PCP103—PRACTICAL MIDI HANDBOOK \$9.95. Explains what MIDI (the Musical Digital Interface) can do and how you can put it to work. Covers keyboards, drum machines, sequencers, mixers, guitars and computer music.



RFTD—RADIO'S FIRST TWO DECADES \$3.50. This story of radio's early days makes for fascinating reading. Spark-gap transmitters, KDKA's beginnings, and much more.



PCP102—INTRODUCING DIGITAL AUDIO \$9.95. CD, DAT and sampling. What is involved in the digital part of audio signals. Principles and practices of digital audio techniques.

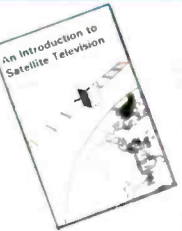

BP195—INTRODUCTION TO SATELLITE TV..... \$8.00. A definitive introduction to the subject written for the professional engineer, electronics enthusiast, or others who want to know more before they buy a 10 in.



BP239—GETTING THE MOST FROM YOUR MULTIMETER..... \$5.00. Covers basics of analog and digital meters. Methods of component testing (includes transistors, thyristors, resistors, capacitors and other active and passive devices).



BP135—SECRETS OF THE COMMODORE 64 \$5.00. Masses of useful info and programming tips not found in any user's manual.



BP143—INTRO TO PROGRAMMING THE ATARI 600/800 XL \$5.00. Perfect complement to the Atari user's manual. Even shows how to use animated graphics.



BP148—COMPUTER TECHNOLOGY EXPLAINED \$5.00. Explanations for computer terms often encountered. A dictionary for computer lingo.

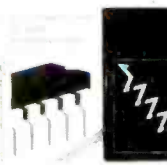

BP152—INTRO TO Z-80 MACHINE CODE \$5.95. Speed up your programs. They may be harder to write, but it's worth learning how. Some demo programs are included.

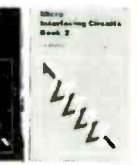

BP151—INTRO TO Z-80 MACHINE CODE \$5.95. Speed up your programs. They may be harder to write, but it's worth learning how. Some demo programs are included.



BP105—ANTENNA PROJECTS \$5.00. Practical radio antenna designs that deliver good performance and are relatively simple and inexpensive to build.



BP198—AN INTRODUCTION TO ANTENNA THEORY \$6.95. Basic concepts relevant to receiving and transmitting antennas.



BP144—FURTHER PRACTICAL ELECTRONICS CALCULATIONS AND FORMULAE..... \$9.00. Companion volume to BP53. Book carries on with new data not found in earlier edition. 450 pages.



BP179—ELECTRONIC CIRCUITS FOR THE COMPUTER CONTROL OF ROBOTS \$5.00. Data and circuits for interfacing the computer to the robot's motors and sensors.



BP125—25 SIMPLE AMATEUR BAND ANTENNAS \$5.00. All kinds of antennas for all kinds of amateur radio reception.



BP134—EASY ADD-ON PROJECTS FOR COMMODORE 64, VIC-20, BBC MICRO & ACORN ELECTRON \$6.95. Picture digitizer, light pen, model controller and more.



BP130—MICRO INTERFACING CIRCUITS—BOOK 1 \$5.75. Practical add-ons transform your computer into control or measurement equipment.



BP131—MICRO INTERFACING CIRCUITS—BOOK 2 \$5.75. Interfacing sound and speech generators, temperature and optical sensors, motor controllers and more.

Quality Paperbacks



BP163—AN INTRODUCTION TO CP/M \$5.75. To run and use programs operators under CP/M you need this book.



BP127—HOW TO DESIGN ELECTRONIC PROJECTS \$5.75. How to use standard circuit elements to make custom electronic projects.



BP110—HOW TO GET YOUR ELECTRONIC PROJECTS WORKING \$5.00. How to find the faults in your projects, repair them and get them working.



BP121—DESIGN & MAKE YOUR OWN PC BOARDS \$5.75. Everything you need to know before you make printed circuit boards for your projects.



BP111—DESIGN & MAKE YOUR OWN PC BOARDS \$5.75. Everything you need to know before you make printed circuit boards for your projects.



BP85—INTERNATIONAL TRANSISTOR EQUIVALENTS \$7.50. Locates possible substitutes for a popular user-oriented selection of modern transistors. Japanese, European and American types.



BP85—INTERNATIONAL TRANSISTOR EQUIVALENTS \$7.50. Locates possible substitutes for a popular user-oriented selection of modern transistors. Japanese, European and American types.



BP56—ELECTRONIC SECURITY DEVICES \$5.00. Three basic sections. Switch activated alarms, infrared & ultrasonic systems, smoke, gas, water detection.



BP117—PRACTICAL ELECTRONIC BUILDING BLOCKS, Book 1 \$5.75. Build the blocks and then combine them to form almost any custom project of your choice.



BP118—PRACTICAL ELECTRONIC BUILDING BLOCKS, Book 2 \$5.75. Amplifiers for all kinds to add to the circuits from Book 1 of this series.



BP169—HOW TO GET YOUR COMPUTER PROGRAMS RUNNING \$5.95. Have you ever written your own programs only to find that they do not work? This book shows you how to find errors.



BP169—HOW TO GET YOUR COMPUTER PROGRAMS RUNNING \$5.95. Have you ever written your own programs only to find that they do not work? This book shows you how to find errors.

Affordable Prices



BP128—20 PROGRAMS FOR THE ZX SPECTRUM & 16K ZX81 \$5.75. All programs run on both machines. Include flow charts and info on how to modify in run on other computers.



BP106—MODERN OP-AMP PROJECTS \$5.00. Includes a Slide Timer, AF Signal Gen, Mike Pre-amp, Scratch Filter, and much more.



BP59—SECOND BOOK FOR CMOS IC PROJECTS \$5.00. Multivibrators, amplifiers, triggers & gates, special devices including reconfigurable sample electronic organ, and more.



BP182—MIDI PROJECTS \$6.95. Details of how to interface many popular home computers with MIDI music systems.



BP65—SINGLE IC PROJECTS \$4.95. All projects in this book are based on one IC and are simple to construct. Great way to get started with IC's.



BP49—POPULAR ELECTRONIC PROJECTS \$5.50. A collection of a wide range of electronic projects and circuits for the experimenter.



BP97—IC PROJECTS FOR BEGINNERS \$5.00. Written especially for the less experienced experimenter. Complete parts layouts and wiring diagrams.



BP98—POPULAR ELECTRONIC CIRCUITS, Book 2 \$5.75. More useful circuits. None of these projects duplicate those in Book 1 of this series.



BP161—INTO THE QL ARCHIVE \$5.95. Presents the powerful database for the Sinclair QL. Step-by-step approach includes practical examples.



BP97—IC PROJECTS FOR BEGINNERS \$5.00. Written especially for the less experienced experimenter. Complete parts layouts and wiring diagrams.



BP98—POPULAR ELECTRONIC CIRCUITS, Book 2 \$5.75. More useful circuits. None of these projects duplicate those in Book 1 of this series.

CHECK OFF THE BOOKS YOU WANT

ELECTRONIC TECHNOLOGY TODAY INC.
P.O. Box 240, Massapequa Park, NY 11762-0240

SHIPPING CHARGES IN USA AND CANADA

SORRY, No orders accepted outside of USA and Canada

Number of books ordered

Name _____
Address _____
City _____ State _____ Zip _____

\$0.01 to \$5.00	... \$1.25
\$5.01 to 10.00	... \$2.00
\$10.01 to 20.00	... \$3.00
\$20.01 to 30.00	... \$4.00
\$30.01 to 40.00	... \$5.00
\$40.01 to 50.00	... \$6.00
\$50.01 and above	... \$7.50

Total price of merchandise \$ _____
Sales Tax (New York State Residents only) \$ _____
Shipping (see chart) \$ _____
Total Enclosed \$ _____

H9-88

All payments must be in U.S. funds